

Complete delivery range

rothe erde[®] slewing bearings

Customer-specific
solutions for individual
requirements



thyssenkrupp



Explanations of the abbreviations in the table header

Geometry	D_L	Raceway diameter
	D_a	External diameter
	D_i	Internal diameter
	H	Overall height
	O	Diameter
	U	Diameter
	A	Diameter
	C	Diameter
	H₁	Ring height
	H₂	Ring height
	H_u	Distance between bottom outer ring/inner ring
	H_o	Distance between top outer ring/inner ring
Attachment	L_a	Outside bolt-hole circle diameter
	L_i	Inside bolt-hole circle diameter
	n	Number of holes per bolt-hole circle
	n_a	Number of holes on outside
	n_i	Number of holes on inside
	B	Hole diameter
	M	Bolt size
Gearing	t	Thread depth
	d	Bolt-hole circle diameter
	m	Module
	z	Number of teeth
	x · m	Profile shift, sign DIN 3960, October 1976
	k · m	Tip height modification
	b / b_{min}	Tooth width / minimum tooth width
	Z_u	Diameter of tooth neck high at root
	h_u	Tooth neck high
	X1	Permitted circumferential forces normal
	X2	Permitted circumferential forces maximum
Miscellaneous	W	Weight
	n₁	Number of grease nipples
	Y	Bearing play values: (axial / radial)

Structure of the drawing number

This drawing number describes by way of example the series 01:

Double-row ball bearing with external gearing,
 Roller body diameter 20 mm,
 Raceway diameter 755 mm,
 without variant counting number.

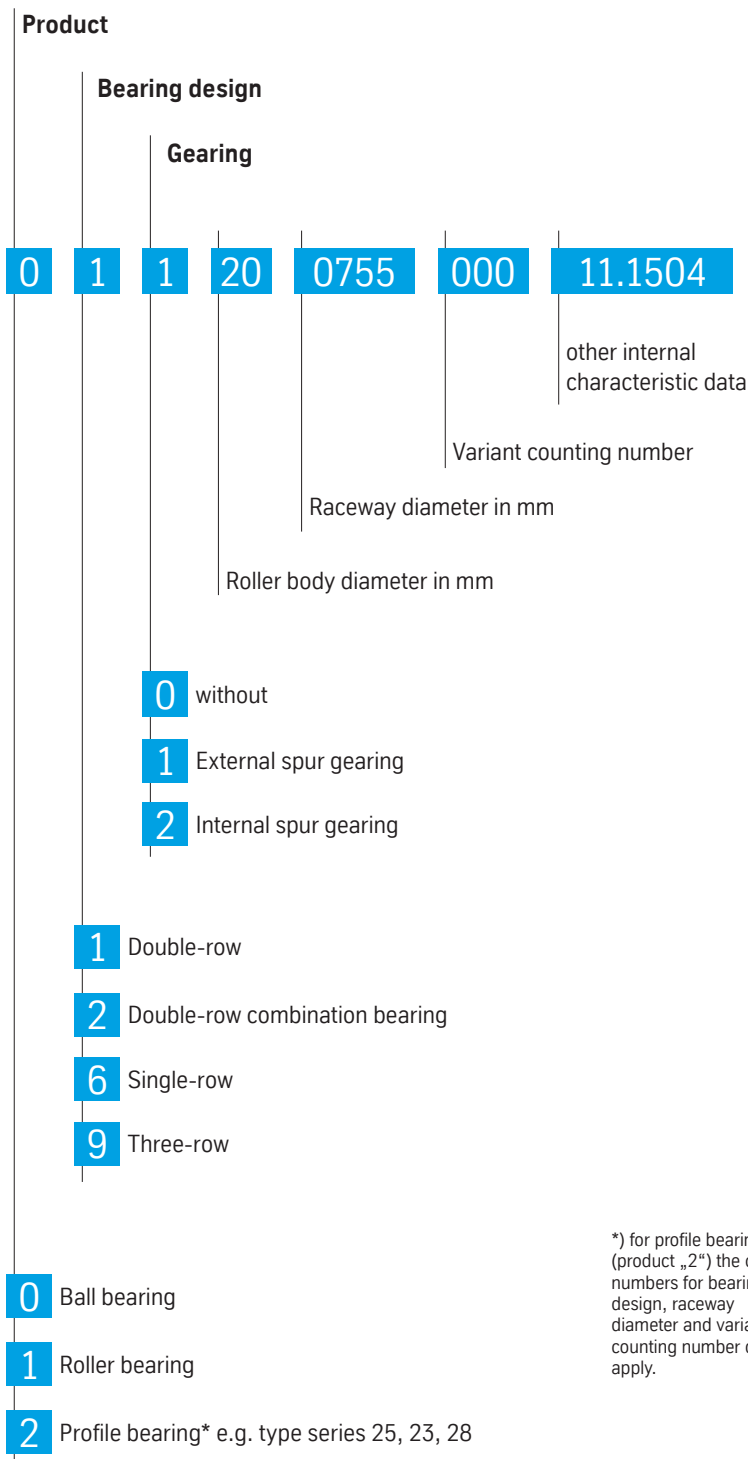

rothe erde[®]
Slewing Bearings –
Customer-specific
solutions for individual
requirements

Content

006 thyssenkrupp rothe erde

006	What drives us
008	Where we are
010	Where we come from
012	What we offer
014	Where you can find us

016 Bearing types and sample applications

016	Series 01, double-row ball bearing
018	Series 03, axial ball bearing – not self-holding
020	Series 06, single-row four-point bearing
024	Series 08, axial ball bearing – self-holding
026	Series 09, double-row four-point bearing
030	Series 10, four-row roller bearing
032	Series 12, combination bearing
034	Series 13, axial roller bearing
036	Series 14, double-row tapered roller bearing
038	Series 16, crossed roller bearing
040	Series 17, radial roller bearing
042	Series 19, three-row roller bearing
046	Series 23, profile bearing
048	Series 25, profile bearing
050	Series 28, profile bearing
052	Series 75, single-row wire ball bearing
054	Series 80, segmented roller bearing with inserted races
056	Series 81, double-row wire angular contact roller bearing
058	Series 87, three-row wire roller bearing

060 Calculation

060	Bearing selection in general
061	Load factors for determining bearings
062	Load transmission
064	Inquiry data
066	Sample bearing selection for a slewing crane
069	Utilization period
070	Sample calculation for utilization period
072	Innovative calculation of slewing bearings
074	Calculation of the friction moment

076 Bearing selections (tables)

076	Series 25, 23, 28, profile bearing
112	Series 06, single-row four-point bearing
164	Series 09, double-row four-point bearing
184	Series 19, three-row roller bearing

208 Bearing installation, gearing, companion structures, application conditions

208	Screw connection/bolt connections
216	Improvement in the friction coefficient between bearing contact surfaces
218	Gearing
220	Companion structure
222	Application conditions

224 Installation, lubrication, maintenance, bearing inspection

224	Installation · Lubrication · Maintenance (ILM)
232	Bearing inspection

240 Service

240	After Sales Service
-----	---------------------

We keep the future
world turning.



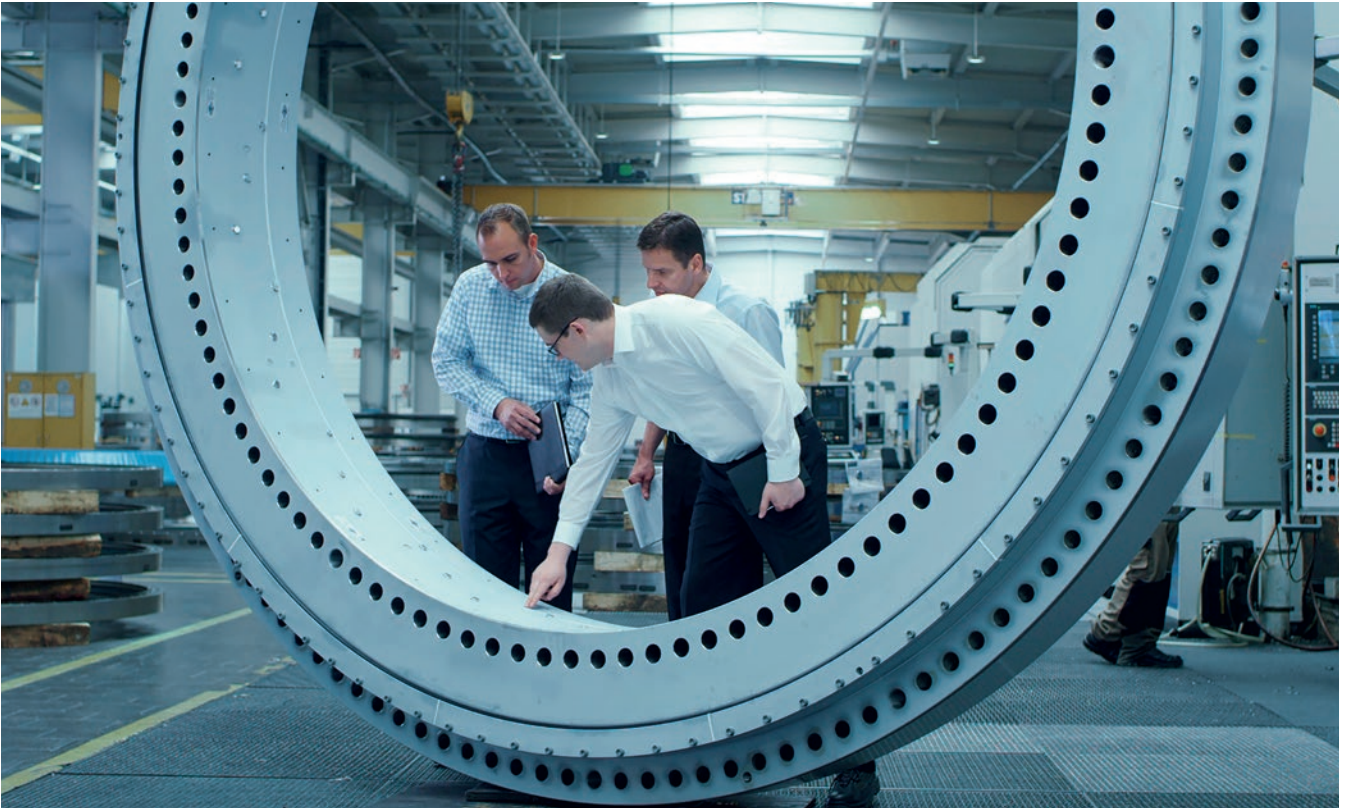

Our future
is as
perfect
as a circle.

Our partners understand:

Motion means security, progress and a future perspective.
We at thyssenkrupp rothe erde are the leading global manufacturer of slewing bearings, rolling bearings and one of the largest producers of seamless rolled rings. Every day, we contribute to keeping everything rolling smoothly – all around the world.



We're there where you need us.

Greatness is not just a matter of opinion.
It's what our work requires.

thyssenkrupp rothe erde is specialized in the production of slewing bearings, rolling bearings and seamless rolled rings which are used in a wide range of industries. Every month more than 7,000 employees transform 15,000 tons of steel into customer-specific solutions.

thyssenkrupp rothe erde Slovakia a.s.
thyssenkrupp rothe erde Germany GmbH
thyssenkrupp rothe erde UK Ltd.
thyssenkrupp rothe erde Italy S.p.A.
thyssenkrupp rothe erde France
thyssenkrupp rothe erde Spain S.A.



Around the world – thyssenkrupp rothe erde

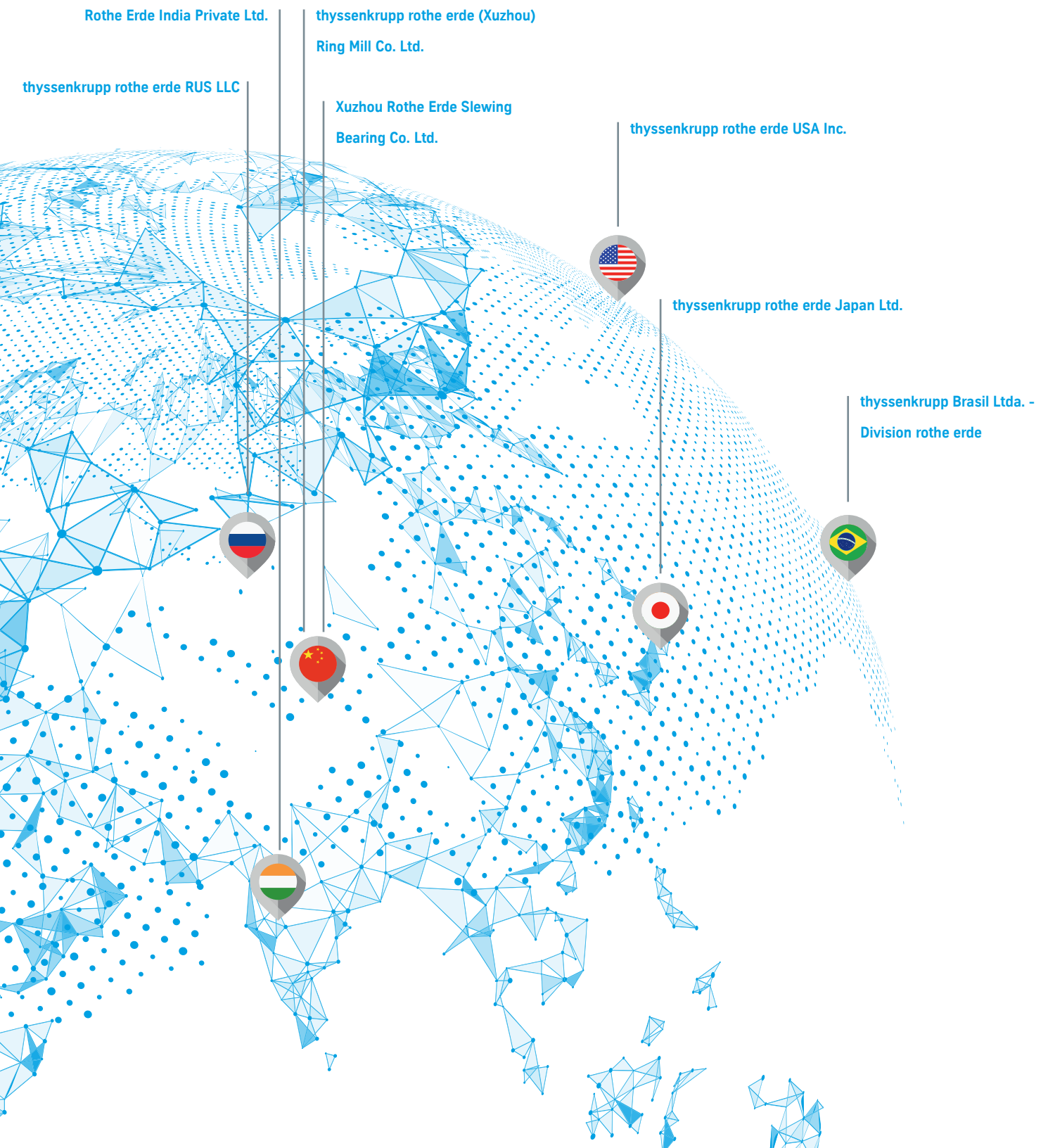

Today and in the future.

34 67

1934

Foundation of the company
Eisenwerk Rothe Erde GmbH
Start of slewing bearing production

1967

Expansion to include production facility in Japan

1975

Expansion by production facilities in Italy, Spain and England

1962

Foundation of the first production facility in the USA

1855

Foundation of Paulinenhütte Eisen-, Hammer- und Walzwerk Dortmund

55

62

75

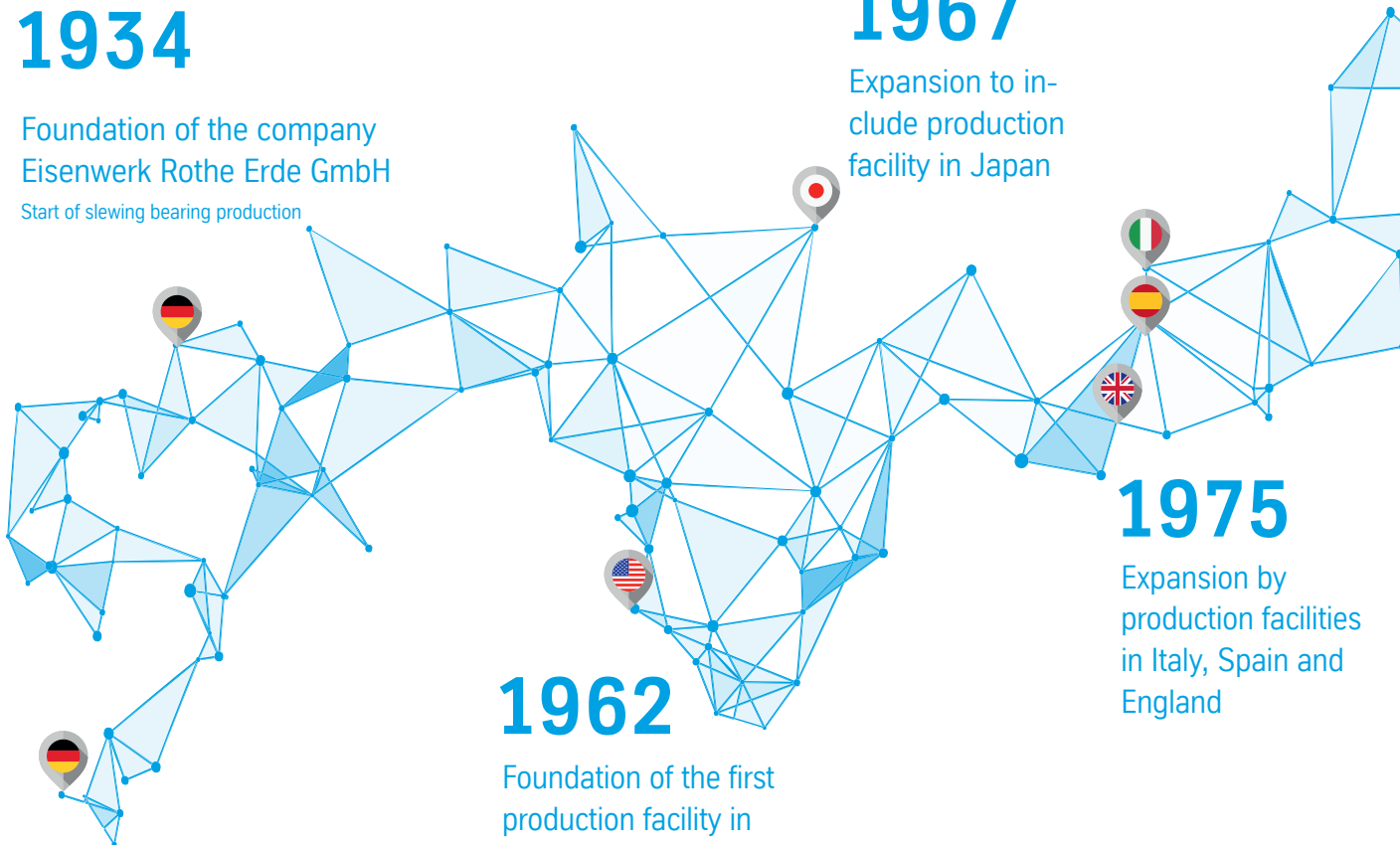

76 02 18



1976

New foundation of the plant in Brazil

2002

Expansion to include a production facility in China



1995

Expansion by production facility in Slovakia



2006

Foundation of further production facilities in China and India



2018

Uniform global presence as thyssenkrupp rothe erde Group

95 06



We focus on
individuality
and quality.

thyssenkrupp rothe erde -
Our product brands:

rothe erde® slewing bearings

Of dwarfs and giants

rothe erde® slewing bearings are designed and manufactured exactly to customer requirements.

This ensures finding unique solutions for every construction type, material quality, and performance.

rothe erde® slewing bearings prove themselves day in and day out as key construction and connecting elements.

Global market leader

thyssenkrupp rothe erde produces slewing bearings with diameters of up to 25 meters and seamless rolled rings that weigh up to 30 tons per piece.

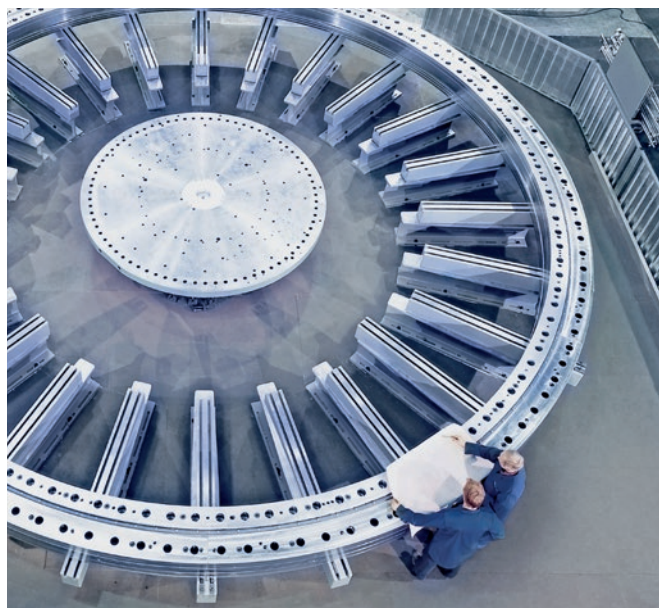



rothe erde® rings

Bulk in perfection

With more than 150 years of experience in the steel industry, rothe erde rings are known for quality and dependability.

With our know-how from free-form and drop forging, we have been able to develop and apply the technology of seamless rolled rings (radial-axial rolling mill technology) right from the beginning with the aim to develop it continuously.

psl® rolling bearings

Quality for heavy-duty and high-precision applications

Under the psl® brand, thyssenkrupp rothe erde manufactures a wide range of single, double and multi-row tapered, cylindrical, toroidal and spherical rolling bearings.

Our bearings are available in various sizes. We are constantly developing our product range, in order to meet market requirements.



Mobility in every way.



Construction and infrastructure

Metropolitan areas are growing at an increased rate. Forecasts predict that in the next 30 years, i.e. within just one generation, another three billion people will move to the world's metropolitan areas. This results in massive challenges not only for transport and traffic, but also for infrastructure and building construction.

At thyssenkrupp rothe erde, we are actively shaping the cities of tomorrow with innovative products: Whether with solutions for passenger transport or for the handling of construction projects.



Renewable energy

As a diversified industrial company with outstanding engineering skills, thyssenkrupp rothe erde supplies innovative products, processes and solutions to meet the growing global demand for energy.

As robust, compact connecting elements, our slewing bearings, rolling bearings and rings in wind turbines, hydroelectric and tidal power plants and solar plants make a significant and sustainable contribution to protecting the climate and resources worldwide.



Mechanical and plant engineering

Mechanical and plant engineering, as a classical engineering science, is a highly innovative industry today.

The continuous development of state-of-the-art processing technologies and the use of high-performance materials allow us to always offer our customers the optimum bearing design.

Slewing bearings and rolling bearings from thyssenkrupp rothe erde are ideal components for bearings in mechanical and plant engineering.



Oil and gas

We at thyssenkrupp rothe erde are meeting the challenges of energy supply: With a broad range of products and services, we are the technology partner for many of the largest companies in the oil and gas industry. We are active in the most important oil and gas markets and can offer our customers a global network of specialists for supplying materials and subcontracting.

This network of locations ensures a high level of quality service all over the world.

Transport and conveyor technology

Our products ensure smooth operation even under the toughest operating conditions. Both in the mines of this world, where large excavators, stackers and reclaimers are in service, and on rough seas, where robust offshore cranes are used for oil production platforms.

thyssenkrupp rothe erde offers special solutions for countless areas of application in transport and conveyor technology.



Precision applications

Certain applications require rolling bearings and slewing bearings with a particularly high degree of precision under exceptional operating conditions. For example, when it comes to the use in or for the observation of space or the safety of patients during a medical examination.

thyssenkrupp rothe erde is home to the world's largest slewing bearing research and development facility for R&D work. The high quality and documentation requirements are ensured by a certified quality management system.

Series 01

Double-row ball bearing

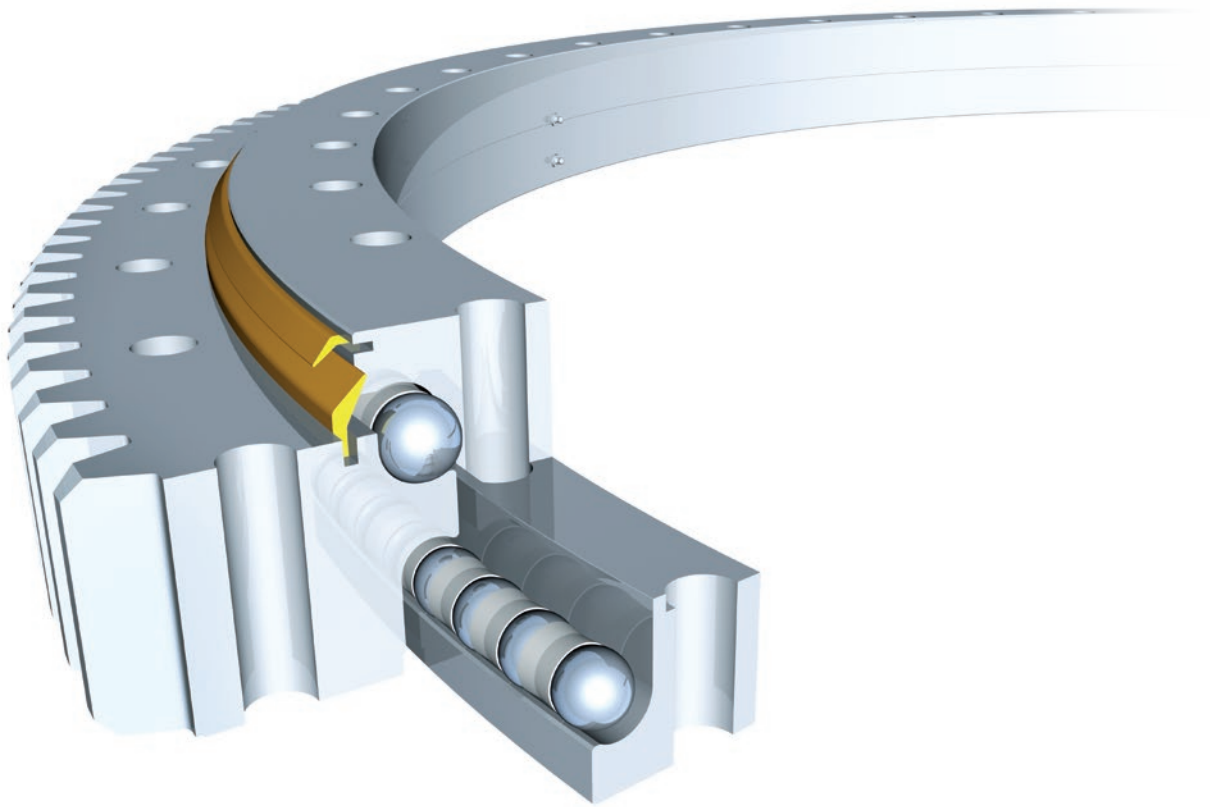

Gearing types

Bearings in Series 01 are supplied

- ⊖ without gearing
- ⊕ with external gearing
- ⊖ with internal gearing



Areas of application

Aerial Hydraulic Platforms • Antennas • Arc Furnaces • Band Conveyor • Blast Furnace Gas Cover • Casting Equipment • Construction Machinery • Container Spreader • Crane Wheel Bogie • Deck Cranes • EDS Scanner • Excavators • Fifth Wheel/Trailer Bogie • Gantry Cranes • Ladle Turrets • Machine Tools • Mechanical Engineering • Medical Equipment • Mixer • Mobile Cranes • Mooring station • Offshore Crane • Packaging or Bottling Equipment • Paddle Wheel Bearings • Ship Loader/Unloader • Solar Energy Plants • Special Sales • Stackers/Reclaimers • Swivel Bearings • Telescopes • Thruster • Tidal Energy Plants • Tower Cranes • Truck Mounted Cranes • Tunnel Boring Machines • Water Treatment Equipment • Wind Energy Plants

Series 03

Axial ball bearing – not self-holding

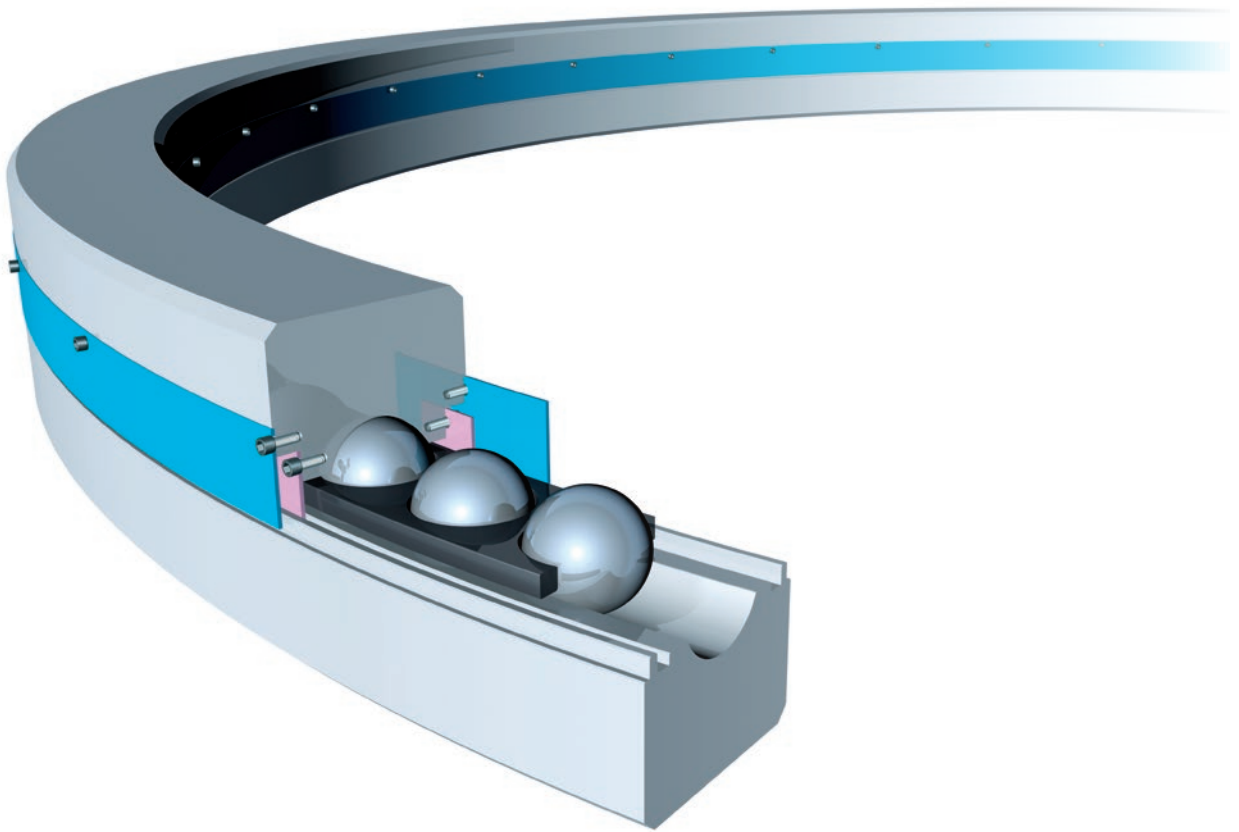

Gearing types

Bearings in Series 03 are supplied

- ⊖ without gearing
- ⊕ with external gearing
- ⊗ with internal gearing



Areas of application

Aerial Hydraulic Platforms • Antennas • Arc Furnaces • Band Conveyor • Blast Furnace Gas Cover • Casting Equipment • Construction Machinery • Container Spreader • Crane Wheel Bogie • Deck Cranes • EDS Scanner Excavators • Fifth Wheel/Trailer Bogie • Gantry Cranes • Ladle Turrets • Machine Tools • Mechanical Engineering Medical Equipment • Mixer • Mobile Cranes • Mooring station • Offshore Crane • Packaging or Bottling Equipment Paddle Wheel Bearings • Ship Loader/Unloader • Solar Energy Plants • Special Sales • Stackers/Reclaimers Swivel Bearings • Telescopes • Thruster • Tidal Energy Plants • Tower Cranes • Truck Mounted Cranes • Tunnel Boring Machines • Water Treatment Equipment • Wind Energy Plants

Series 06

Single-row four-point bearing

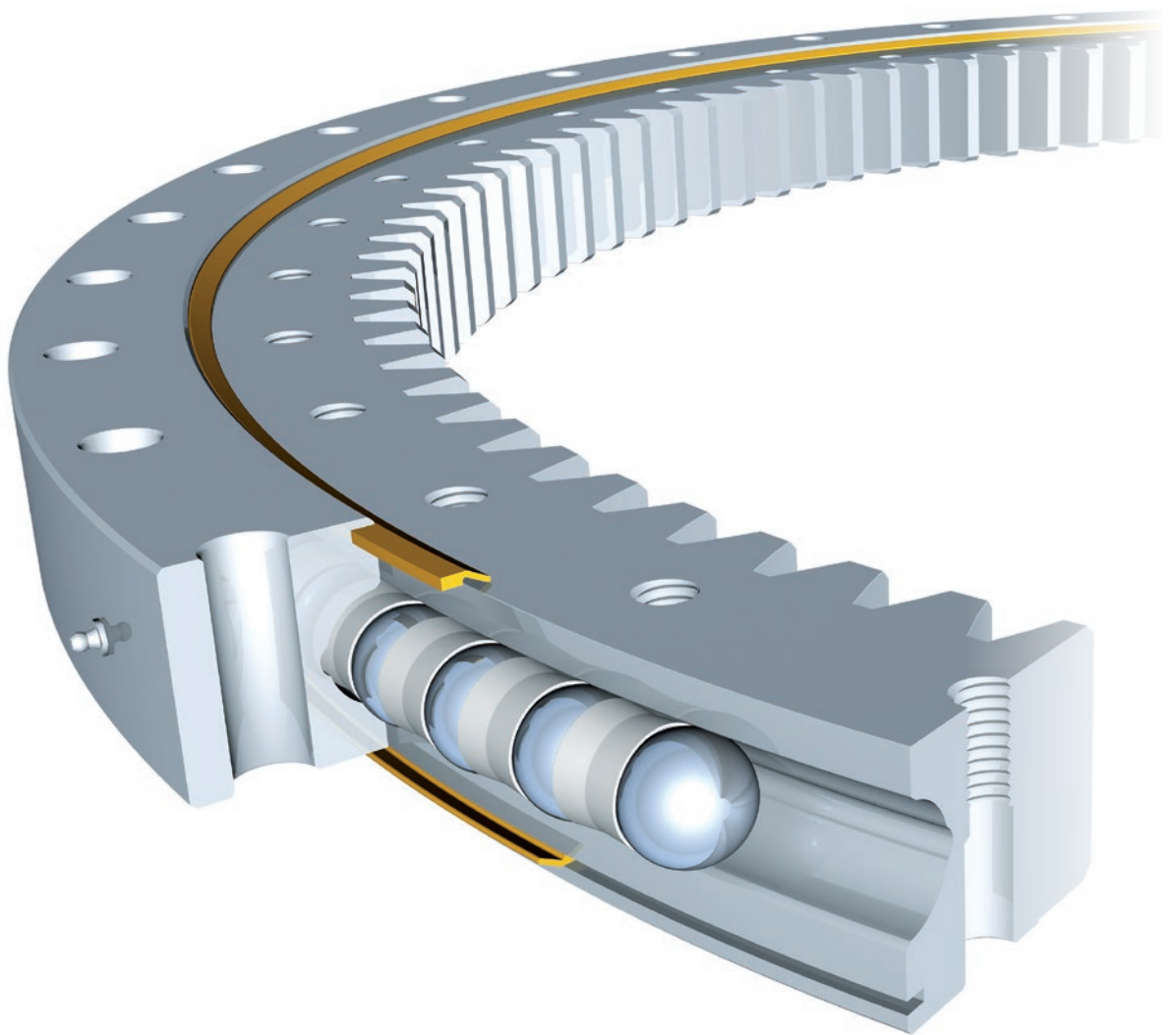

Gearing types

Bearings in Series 06 are supplied

- ⊖ without gearing
- ⊕ with external gearing
- ⊗ with internal gearing



Areas of application

Aerial Hydraulic Platforms • Antennas • Arc Furnaces • Band Conveyor • Blast Furnace Gas Cover • Casting Equipment • Construction Machinery • Container Spreader • Crane Wheel Bogie • Deck Cranes • EDS Scanner Excavators • Fifth Wheel/Trailer Bogie • Gantry Cranes • Ladle Turrets • Machine Tools • Mechanical Engineering Medical Equipment • Mixer • Mobile Cranes • Mooring station • Offshore Crane • Packaging or Bottling Equipment Paddle Wheel Bearings • Ship Loader/Unloader • Solar Energy Plants • Special Sales • Stackers/Reclaimers Swivel Bearings • Telescopes • Thruster • Tidal Energy Plants • Tower Cranes • Truck Mounted Cranes • Tunnel Boring Machines • Water Treatment Equipment • Wind Energy Plants

Series 06

Single-row four-point bearing

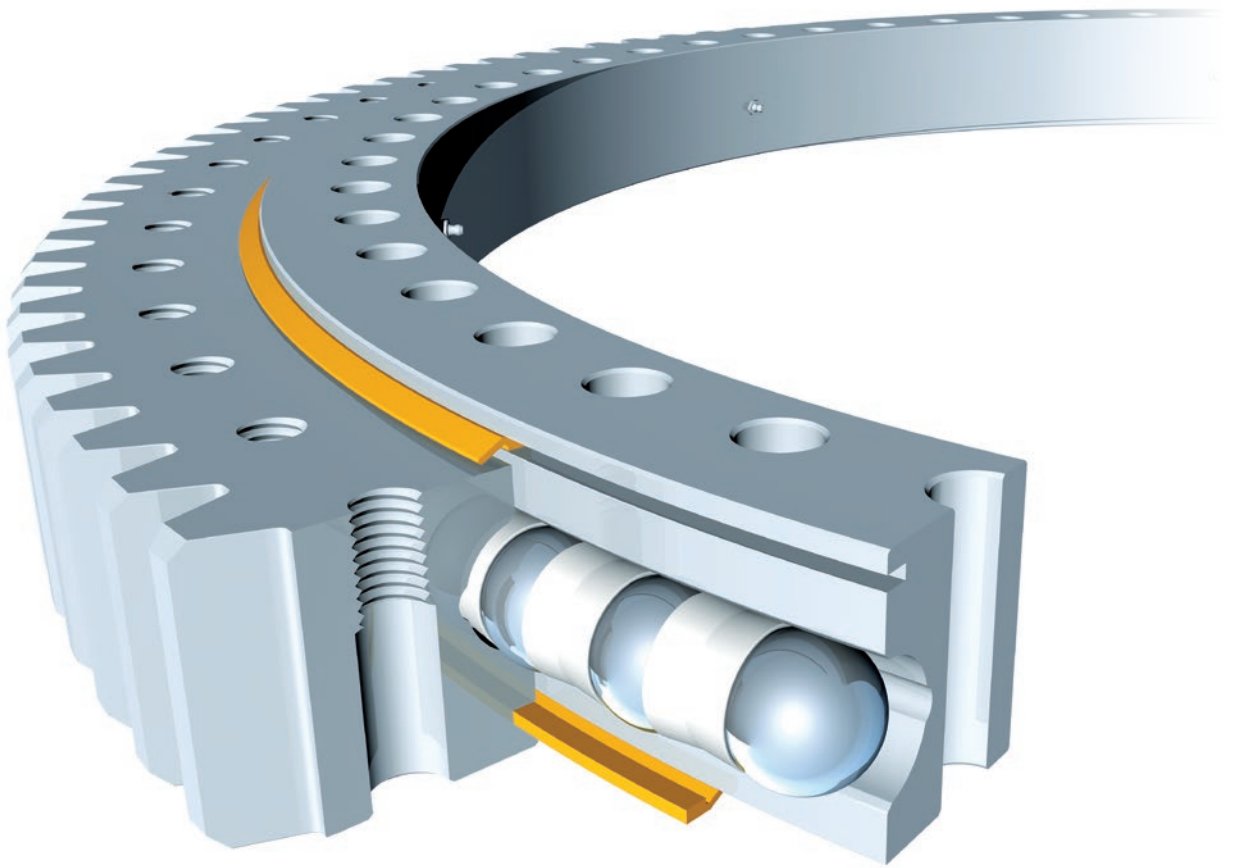

Gearing types

Bearings in Series 06 are supplied

- ⊖ without gearing
- ⊕ with external gearing
- ⊗ with internal gearing



Areas of application

Aerial Hydraulic Platforms • Antennas • Arc Furnaces • Band Conveyor • Blast Furnace Gas Cover • Casting Equipment • Construction Machinery • Container Spreader • Crane Wheel Bogie • Deck Cranes • EDS Scanner Excavators • Fifth Wheel/Trailer Bogie • Gantry Cranes • Ladle Turrets • Machine Tools • Mechanical Engineering Medical Equipment • Mixer • Mobile Cranes • Mooring station • Offshore Crane • Packaging or Bottling Equipment Paddle Wheel Bearings • Ship Loader/Unloader • Solar Energy Plants • Special Sales • Stackers/Reclaimers Swivel Bearings • Telescopes • Thruster • Tidal Energy Plants • Tower Cranes • Truck Mounted Cranes • Tunnel Boring Machines • Water Treatment Equipment • Wind Energy Plants

Series 08

Axial ball bearing - self-holding

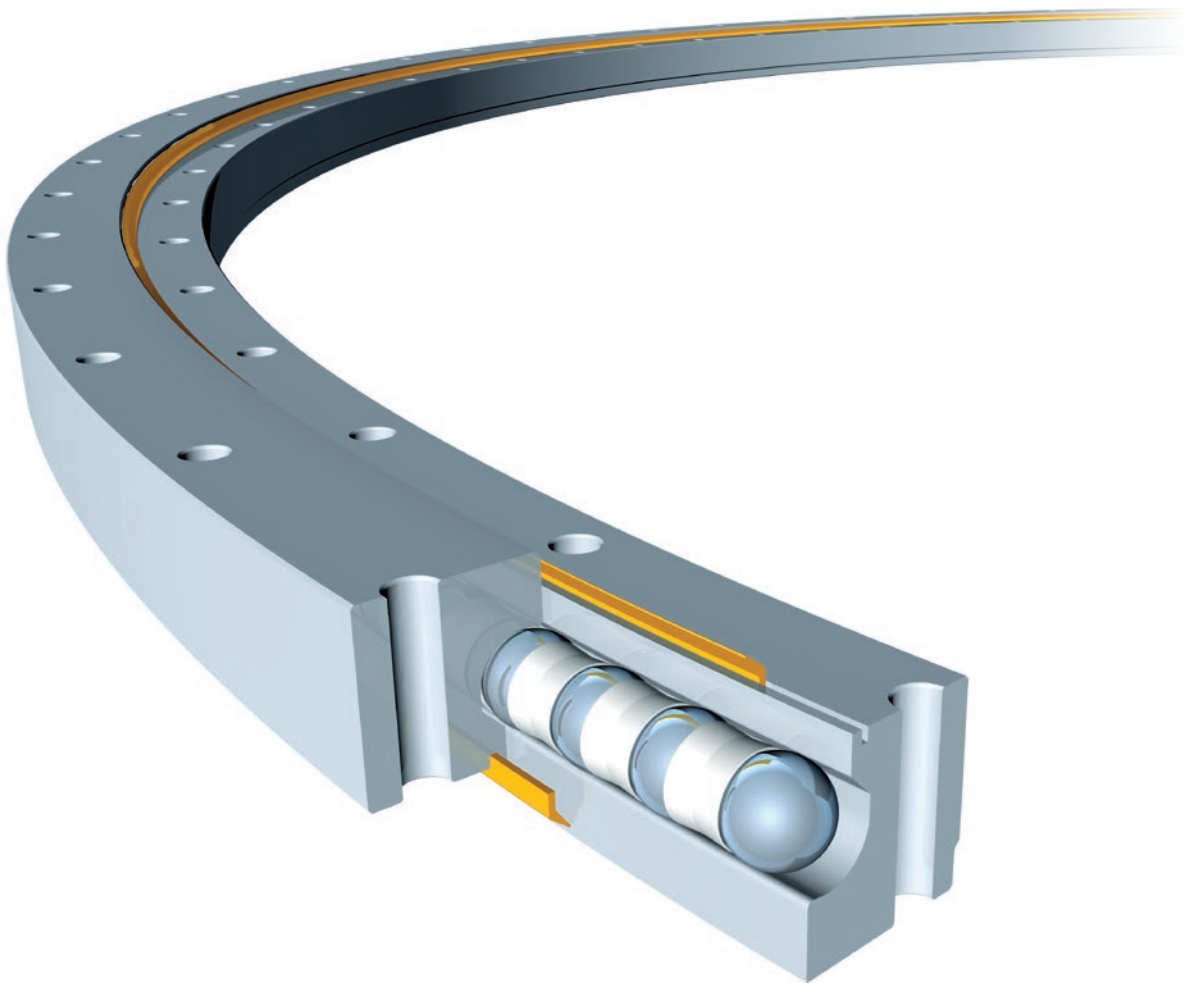

Gearing types

Bearings in Series 08 are supplied

- ⊖ without gearing
- ⊕ with external gearing
- ⊗ with internal gearing



Areas of application

Aerial Hydraulic Platforms • Antennas • Arc Furnaces • Band Conveyor • Blast Furnace Gas Cover • Casting Equipment • Construction Machinery • Container Spreader • Crane Wheel Bogie • Deck Cranes • EDS Scanner Excavators • Fifth Wheel/Trailer Bogie • Gantry Cranes • Ladle Turrets • Machine Tools • Mechanical Engineering Medical Equipment • Mixer • Mobile Cranes • Mooring station • Offshore Crane • Packaging or Bottling Equipment Paddle Wheel Bearings • Ship Loader/Unloader • Solar Energy Plants • Special Sales • Stackers/Reclaimers Swivel Bearings • Telescopes • Thruster • Tidal Energy Plants • Tower Cranes • Truck Mounted Cranes • Tunnel Boring Machines • Water Treatment Equipment • Wind Energy Plants

Series 09

Double-row four-point bearing

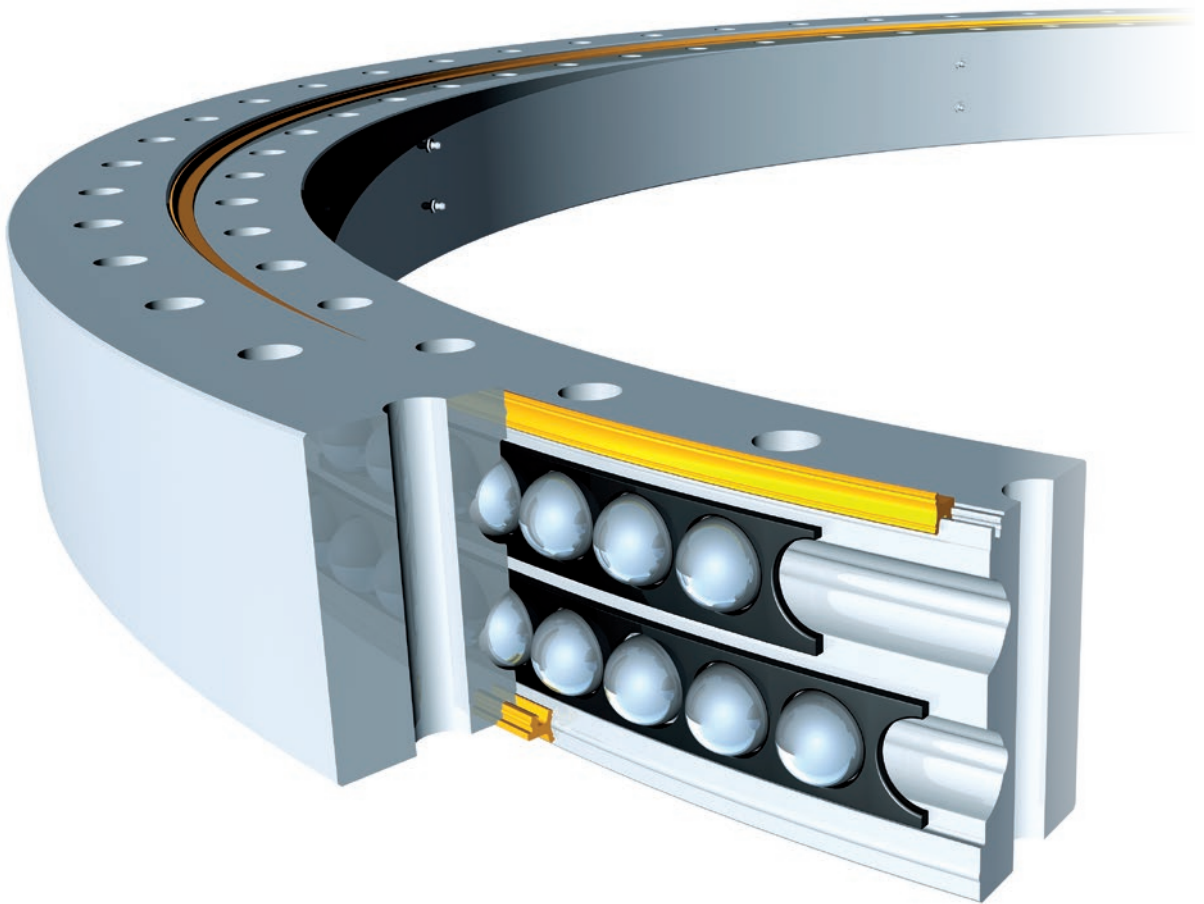

Gearing types

Bearings in Series 09 are supplied

- ⊖ without gearing
- ⊕ with external gearing
- ⊗ with internal gearing



Areas of application

Aerial Hydraulic Platforms • Antennas • Arc Furnaces • Band Conveyor • Blast Furnace Gas Cover • Casting Equipment • Construction Machinery • Container Spreader • Crane Wheel Bogie • Deck Cranes • EDS Scanner • Excavators • Fifth Wheel/Trailer Bogie • Gantry Cranes • Ladle Turrets • Machine Tools • Mechanical Engineering • Medical Equipment • Mixer • Mobile Cranes • Mooring station • Offshore Crane • Packaging or Bottling Equipment • Paddle Wheel Bearings • Ship Loader/Unloader • Solar Energy Plants • Special Sales • Stackers/Reclaimers • Swivel Bearings • Telescopes • Thruster • Tidal Energy Plants • Tower Cranes • Truck Mounted Cranes • Tunnel Boring Machines • Water Treatment Equipment • Wind Energy Plants

Series 09

Double-row four-point bearing

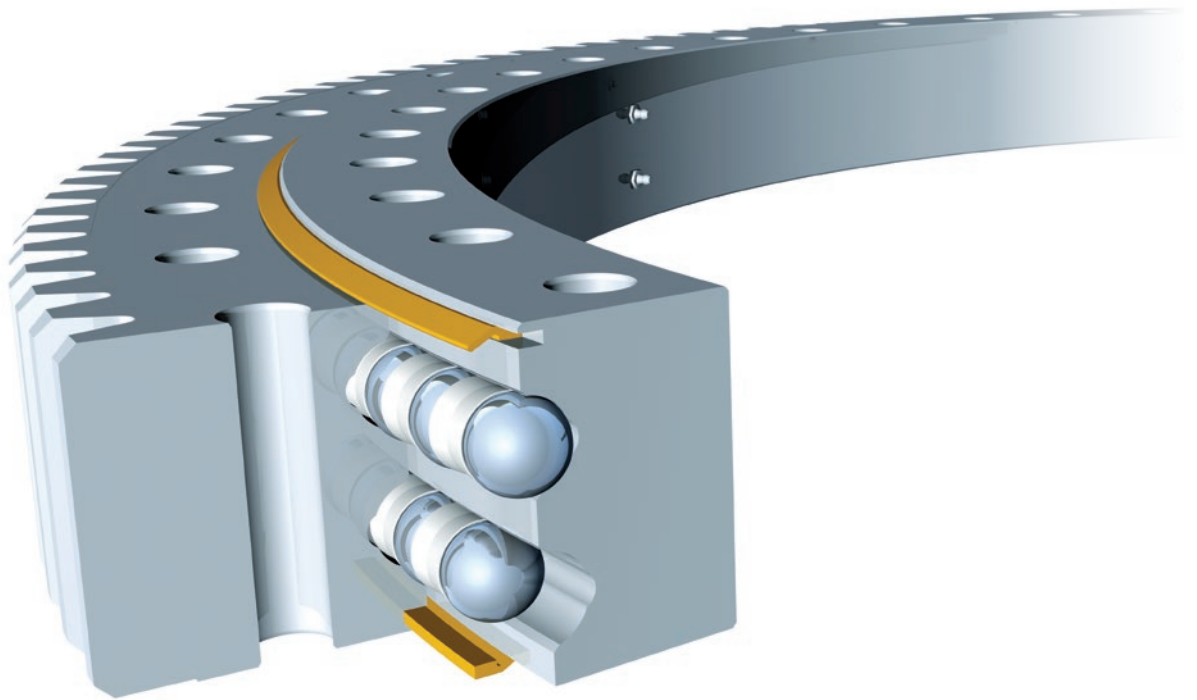

Gearing types

Bearings in Series 09 are supplied

- ⊖ without gearing
- ⊕ with external gearing
- ⊗ with internal gearing



Areas of application

Aerial Hydraulic Platforms • Antennas • Arc Furnaces • Band Conveyor • Blast Furnace Gas Cover • Casting Equipment • Construction Machinery • Container Spreader • Crane Wheel Bogie • Deck Cranes • EDS Scanner • Excavators • Fifth Wheel/Trailer Bogie • Gantry Cranes • Ladle Turrets • Machine Tools • Mechanical Engineering • Medical Equipment • Mixer • Mobile Cranes • Mooring station • Offshore Crane • Packaging or Bottling Equipment • Paddle Wheel Bearings • Ship Loader/Unloader • Solar Energy Plants • Special Sales • Stackers/Reclaimers • Swivel Bearings • Telescopes • Thruster • Tidal Energy Plants • Tower Cranes • Truck Mounted Cranes • Tunnel Boring Machines • Water Treatment Equipment • Wind Energy Plants

Series 10

Four-row roller bearing

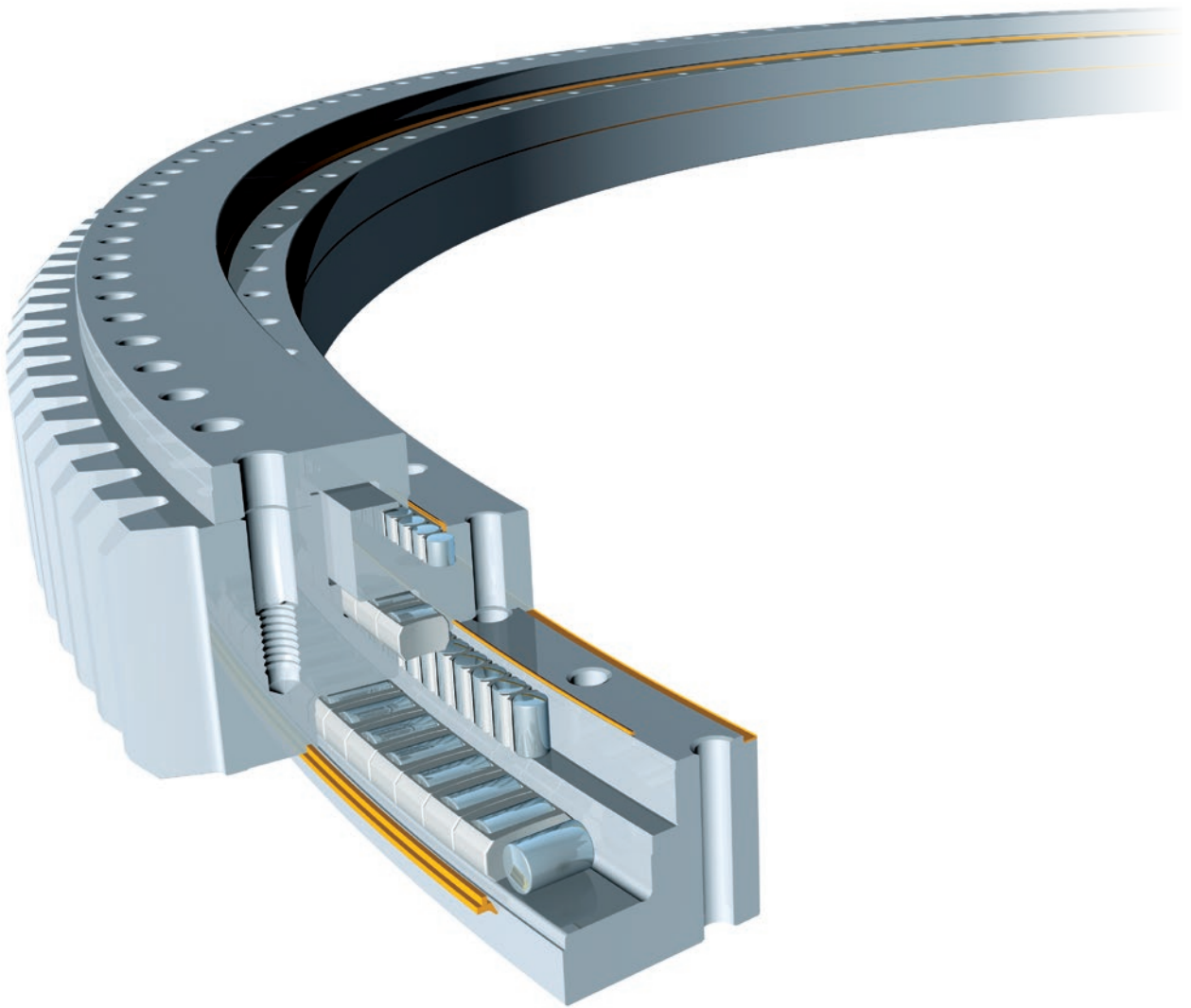

Gearing types

Bearings in Series 10 are supplied

- ⊖ without gearing
- ⊕ with external gearing
- ⊗ with internal gearing



Areas of application

Aerial Hydraulic Platforms • Antennas • Arc Furnaces • Band Conveyor • Blast Furnace Gas Cover • Casting Equipment • Construction Machinery • Container Spreader • Crane Wheel Bogie • Deck Cranes • EDS Scanner Excavators • Fifth Wheel/Trailer Bogie • Gantry Cranes • Ladle Turrets • Machine Tools • Mechanical Engineering Medical Equipment • Mixer • Mobile Cranes • **Mooring station** • **Offshore Crane** • Packaging or Bottling Equipment Paddle Wheel Bearings • Ship Loader/Unloader • Solar Energy Plants • Special Sales • Stackers/Reclaimers Swivel Bearings • Telescopes • Thruster • Tidal Energy Plants • Tower Cranes • Truck Mounted Cranes • Tunnel Boring Machines • Water Treatment Equipment • Wind Energy Plants

Series 12

Combination bearing

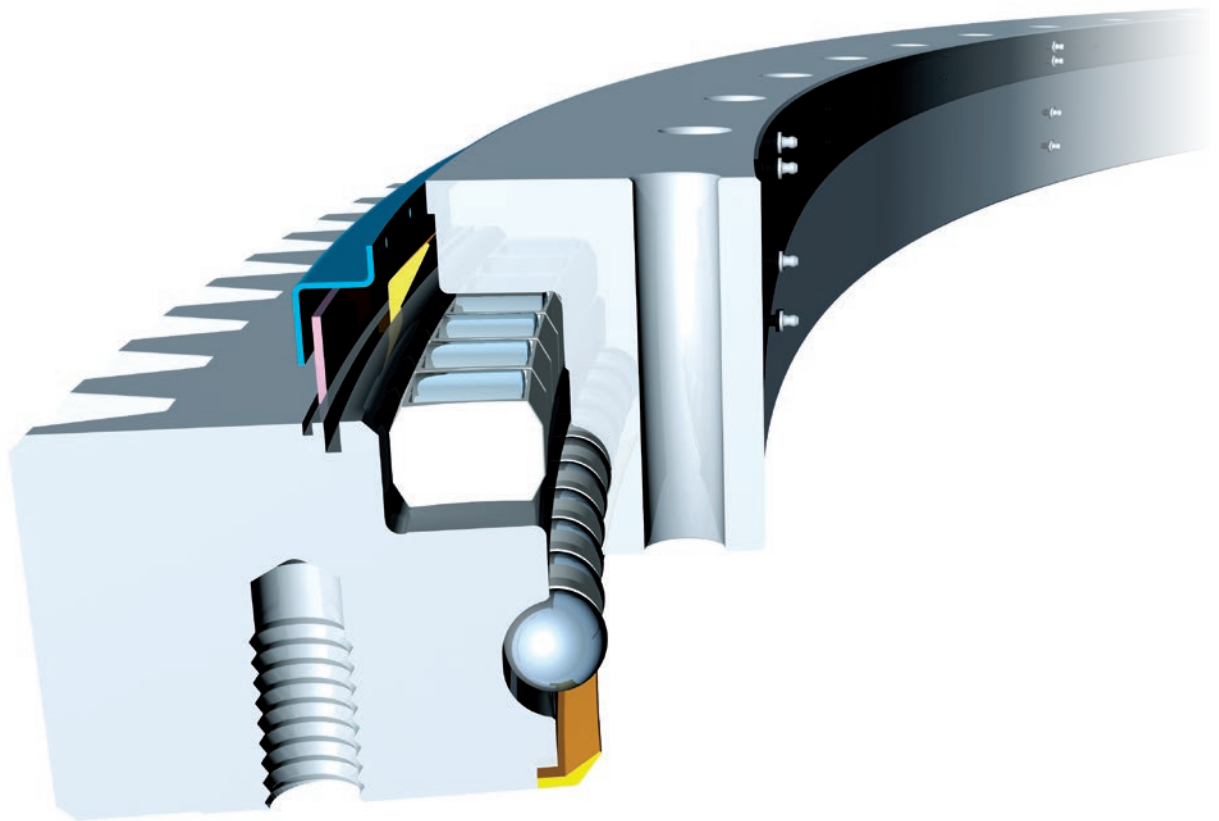

Gearing types

Bearings in Series 12 are supplied

- ⊖ without gearing
- ⊕ with external gearing
- ⊗ with internal gearing



Areas of application

Aerial Hydraulic Platforms • Antennas • Arc Furnaces • Band Conveyor • Blast Furnace Gas Cover • Casting Equipment • Construction Machinery • Container Spreader • Crane Wheel Bogie • Deck Cranes • EDS Scanner Excavators • Fifth Wheel/Trailer Bogie • Gantry Cranes • Ladle Turrets • Machine Tools • Mechanical Engineering Medical Equipment • Mixer • Mobile Cranes • Mooring station • Offshore Crane • Packaging or Bottling Equipment Paddle Wheel Bearings • Ship Loader/Unloader • Solar Energy Plants • Special Sales • Stackers/Reclaimers Swivel Bearings • Telescopes • Thruster • Tidal Energy Plants • Tower Cranes • Truck Mounted Cranes • Tunnel Boring Machines • Water Treatment Equipment • Wind Energy Plants

Series 13

Axial roller bearing

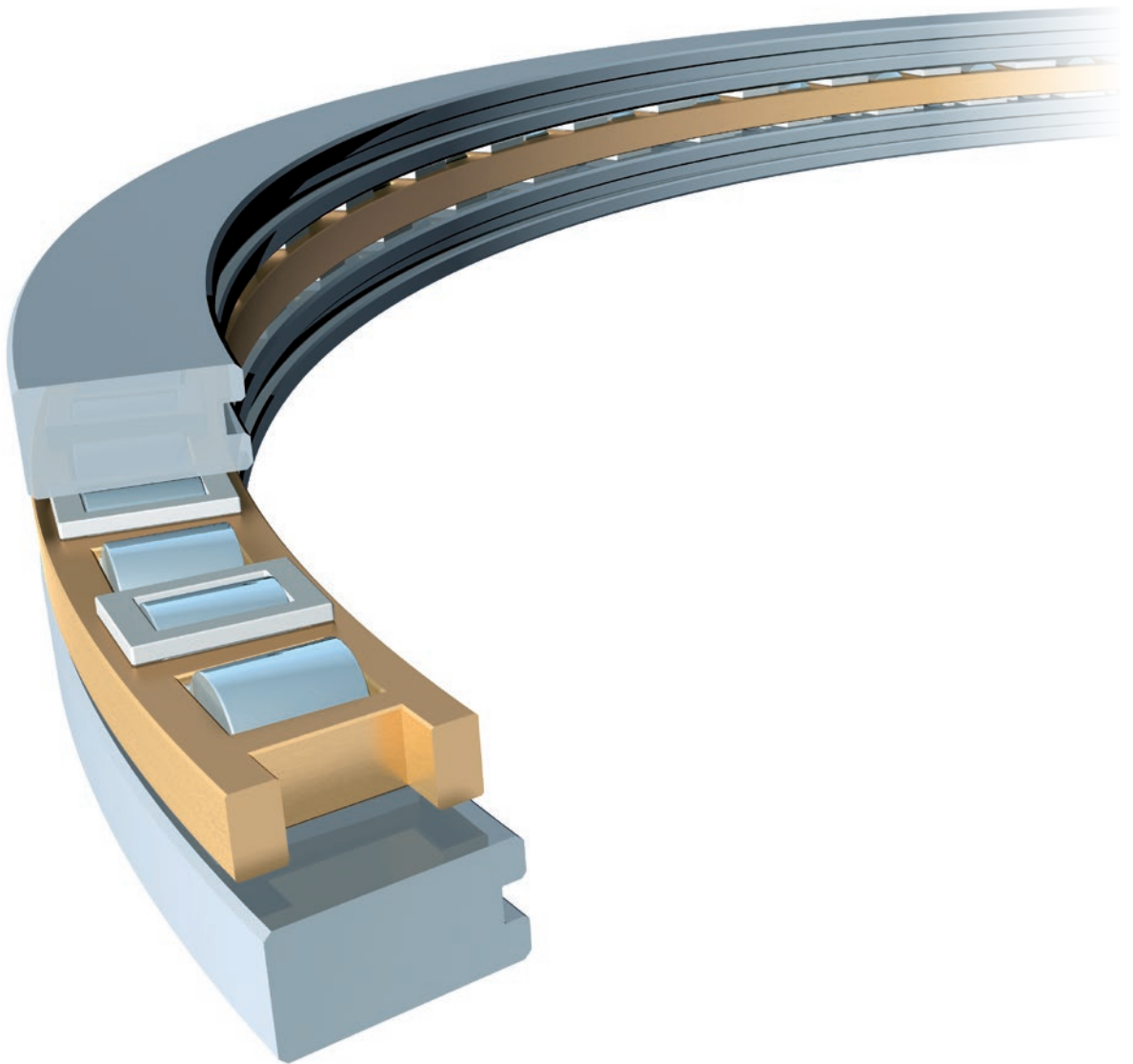

Gearing types

Bearings in Series 13 are supplied
⊖ without gearing

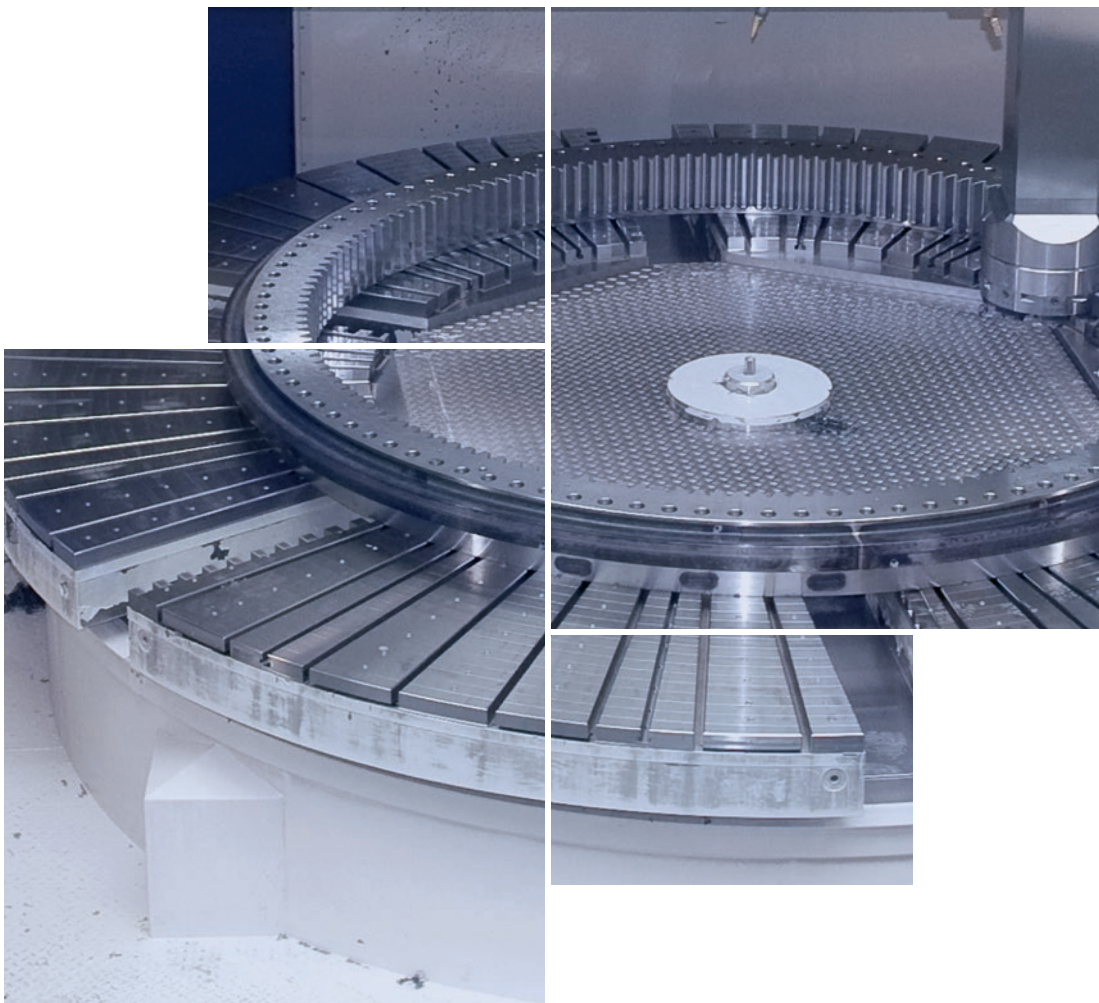

Areas of application

Aerial Hydraulic Platforms • Antennas • Arc Furnaces • Band Conveyor • Blast Furnace Gas Cover • Casting Equipment • Construction Machinery • Container Spreader • Crane Wheel Bogie • Deck Cranes • EDS Scanner Excavators • Fifth Wheel/Trailer Bogie • Gantry Cranes • Ladle Turrets • **Machine Tools** • **Mechanical Engineering** Medical Equipment • Mixer • Mobile Cranes • Mooring station • Offshore Crane • Packaging or Bottling Equipment Paddle Wheel Bearings • Ship Loader/Unloader • Solar Energy Plants • Special Sales • Stackers/Reclaimers Swivel Bearings • Telescopes • Thruster • Tidal Energy Plants • Tower Cranes • Truck Mounted Cranes • Tunnel Boring Machines • Water Treatment Equipment • Wind Energy Plants

Series 14

Double-row tapered roller bearing

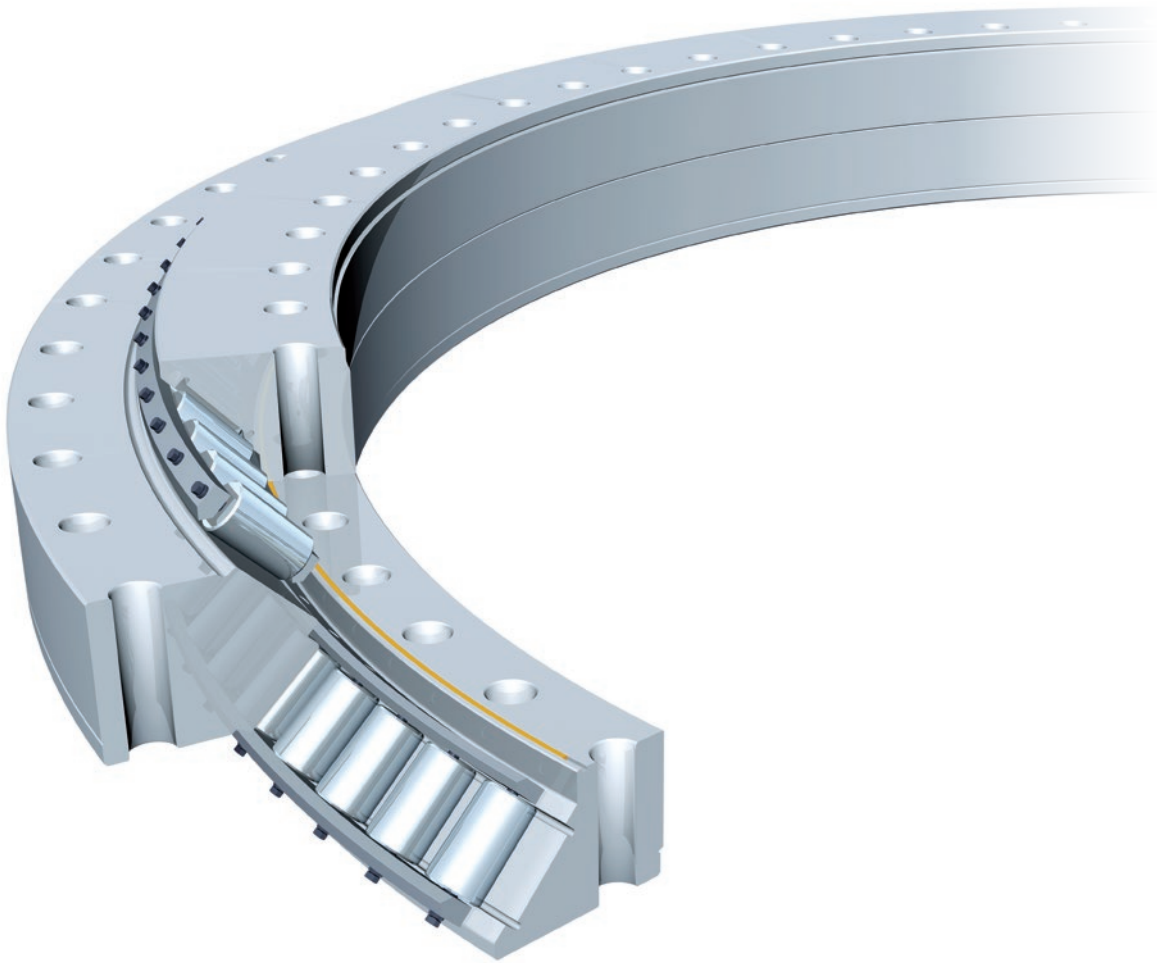

Gearing types

Bearings in Series 14 are supplied
⊖ without gearing



Applications series 14, 16, 17, 19

Areas of application

Aerial Hydraulic Platforms • Antennas • Arc Furnaces • Band Conveyor • Blast Furnace Gas Cover • Casting Equipment • Construction Machinery • Container Spreader • Crane Wheel Bogie • Deck Cranes • EDS Scanner Excavators • Fifth Wheel/Trailer Bogie • Gantry Cranes • Ladle Turrets • Machine Tools • **Mechanical Engineering** Medical Equipment • Mixer • Mobile Cranes • Mooring station • Offshore Crane • Packaging or Bottling Equipment Paddle Wheel Bearings • Ship Loader/Unloader • Solar Energy Plants • Special Sales • Stackers/Reclaimers Swivel Bearings • Telescopes • Thruster • Tidal Energy Plants • Tower Cranes • Truck Mounted Cranes • Tunnel Boring Machines • Water Treatment Equipment • **Wind Energy Plants**

Series 16

Crossed roller bearing

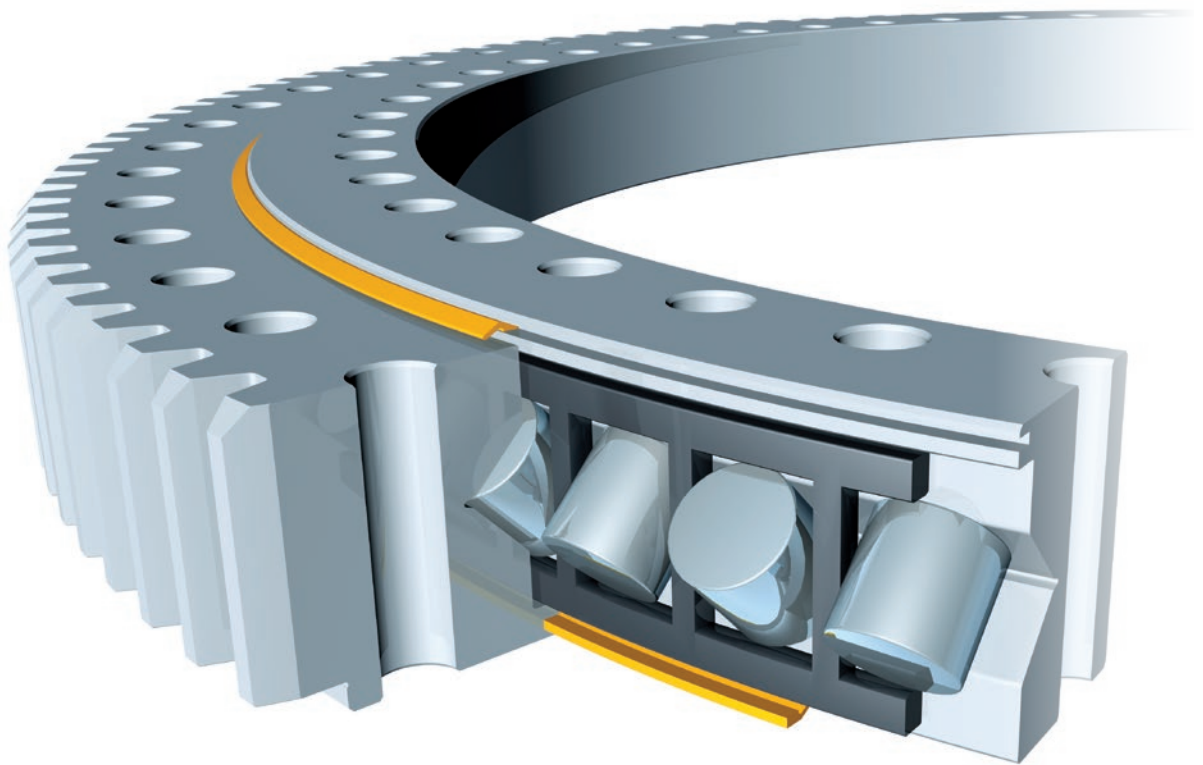

Gearing types

Bearings in Series 16 are supplied

- ⊖ without gearing
- ⊕ with external gearing
- ⊗ with internal gearing

Applications
series
14, 16, 17, 19



© ESO / José Francisco Salgado

Areas of application

Aerial Hydraulic Platforms • Antennas • Arc Furnaces • Band Conveyor • Blast Furnace Gas Cover • Casting Equipment • Construction Machinery • Container Spreader • Crane Wheel Bogie • Deck Cranes • EDS Scanner • Excavators • Fifth Wheel/Trailer Bogie • Gantry Cranes • Ladle Turrets • Machine Tools • Mechanical Engineering • Medical Equipment • Mixer • Mobile Cranes • Mooring station • Offshore Crane • Packaging or Bottling Equipment • Paddle Wheel Bearings • Ship Loader/Unloader • Solar Energy Plants • Special Sales • Stackers/Reclaimers • Swivel Bearings • Telescopes • Thruster • Tidal Energy Plants • Tower Cranes • Truck Mounted Cranes • Tunnel Boring Machines • Water Treatment Equipment • Wind Energy Plants

Series 17

Radial roller bearing

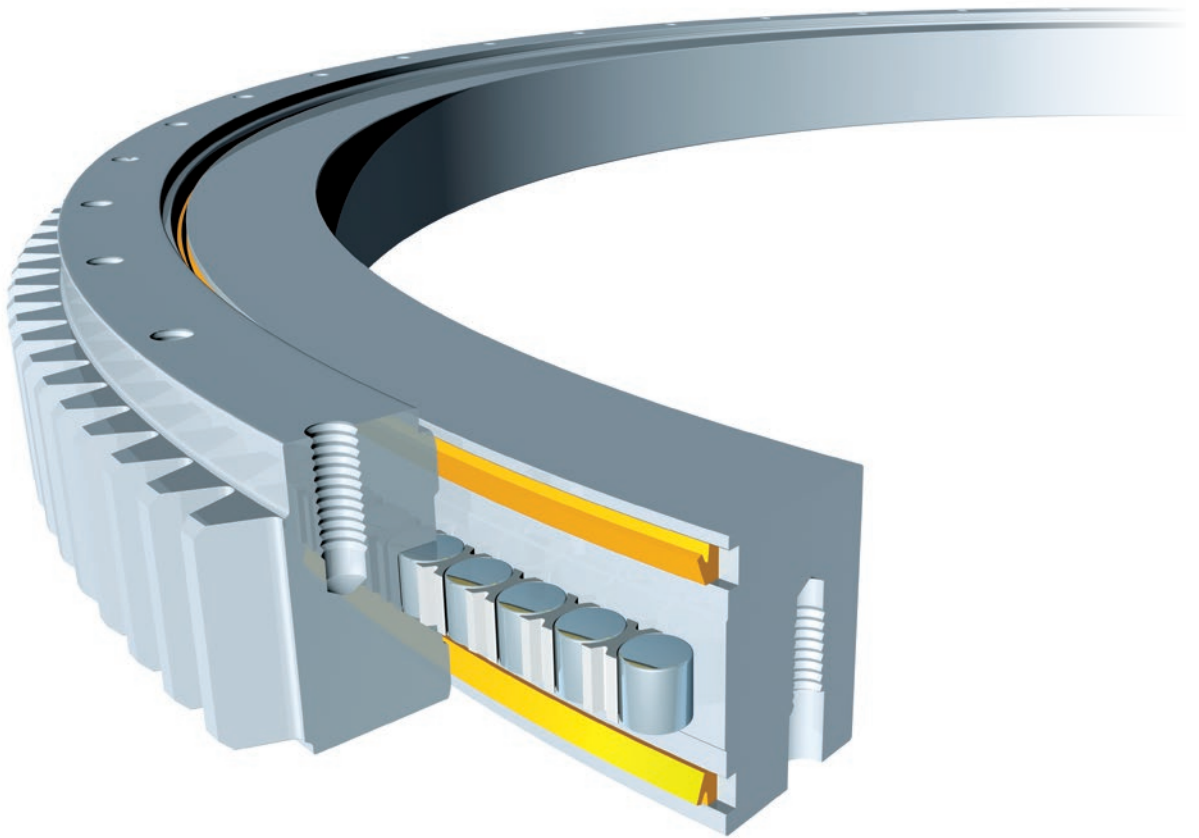

Gearing types

Bearings in Series 17 are supplied

- ⊖ without gearing
- ⊕ with external gearing
- ⊗ with internal gearing

Applications
series
14, 16, 17, 19

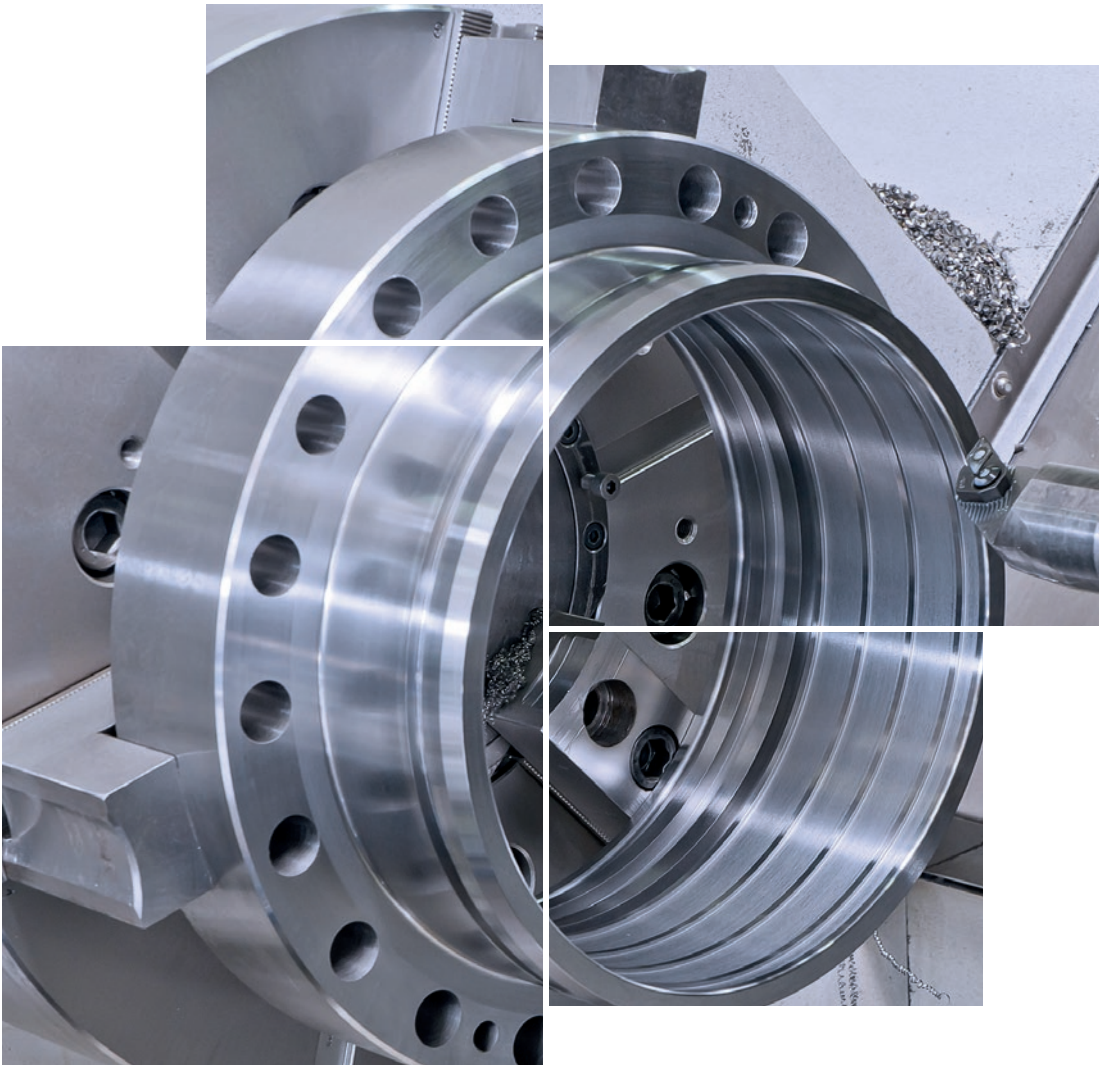

Areas of application

Aerial Hydraulic Platforms • Antennas • Arc Furnaces • Band Conveyor • Blast Furnace Gas Cover • Casting Equipment • Construction Machinery • Container Spreader • Crane Wheel Bogie • Deck Cranes • EDS Scanner Excavators • Fifth Wheel/Trailer Bogie • Gantry Cranes • Ladle Turrets • **Machine Tools** • **Mechanical Engineering** • Medical Equipment • Mixer • Mobile Cranes • Mooring station • Offshore Crane • Packaging or Bottling Equipment • Paddle Wheel Bearings • Ship Loader/Unloader • Solar Energy Plants • Special Sales • Stackers/Reclaimers • Swivel Bearings • Telescopes • Thruster • Tidal Energy Plants • Tower Cranes • Truck Mounted Cranes • Tunnel Boring Machines • Water Treatment Equipment • Wind Energy Plants

Series 19

Three-row roller bearing

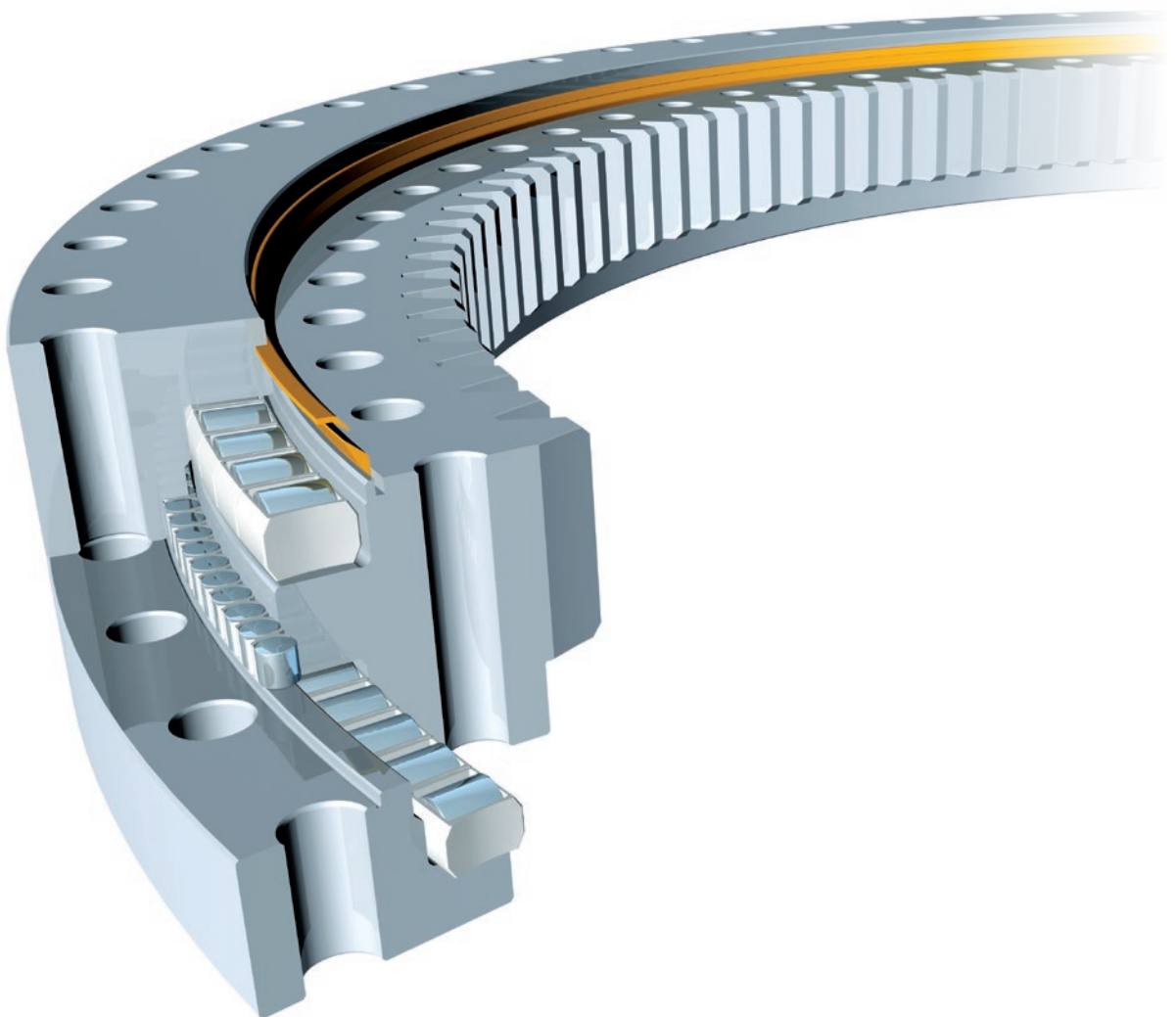

Gearing types

Bearings in Series 19 are supplied

- ⊖ without gearing
- ⊕ with external gearing
- ⊗ with internal gearing

Applications
series
14, 16, 17, 19

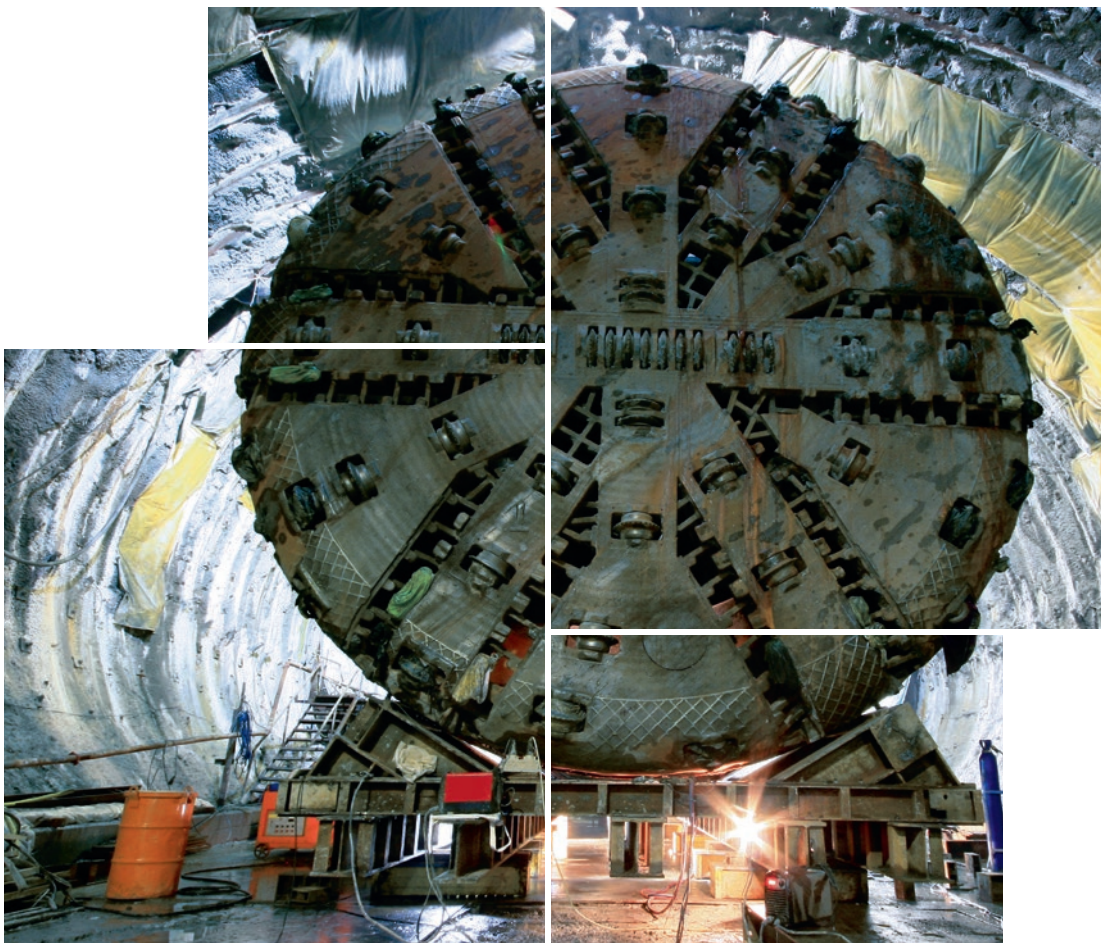

 Page 60
Page 184

Areas of application

Aerial Hydraulic Platforms • Antennas • Arc Furnaces • Band Conveyor • Blast Furnace Gas Cover • Casting Equipment • Construction Machinery • Container Spreader • Crane Wheel Bogie • Deck Cranes • EDS Scanner Excavators • Fifth Wheel/Trailer Bogie • Gantry Cranes • Ladle Turrets • Machine Tools • Mechanical Engineering Medical Equipment • Mixer • Mobile Cranes • Mooring station • Offshore Crane • Packaging or Bottling Equipment Paddle Wheel Bearings • Ship Loader/Unloader • Solar Energy Plants • Special Sales • Stackers/Reclaimers Swivel Bearings • Telescopes • Thruster • Tidal Energy Plants • Tower Cranes • Truck Mounted Cranes • Tunnel Boring Machines • Water Treatment Equipment • Wind Energy Plants

Series 19

Three-row roller bearing

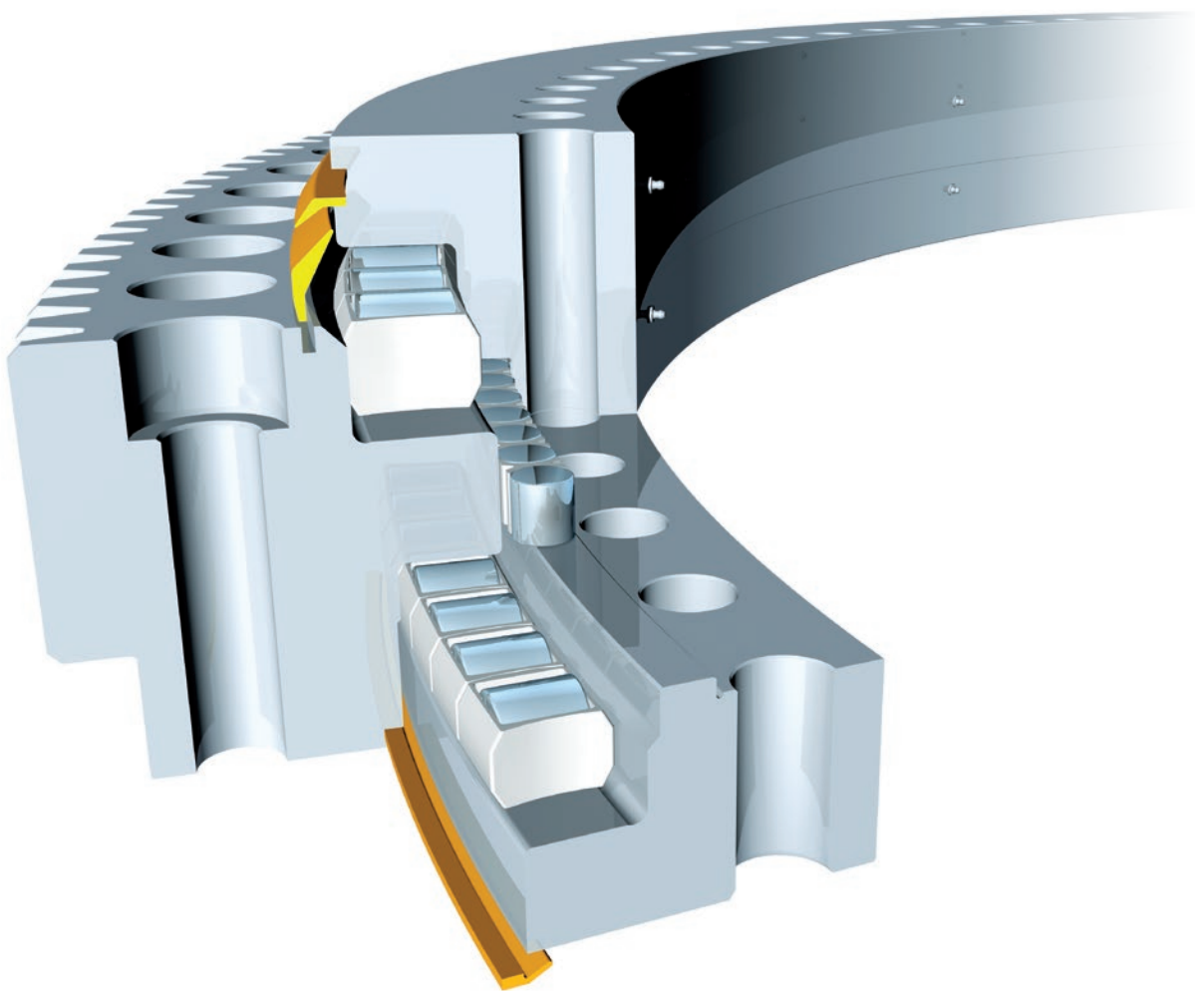

Gearing types

Bearings in Series 19 are supplied

- ⊖ without gearing
- ⊕ with external gearing
- ⊗ with internal gearing

Applications
series
14, 16, 17, 19



 Page 60
Page 184

Areas of application

Aerial Hydraulic Platforms • Antennas • Arc Furnaces • Band Conveyor • Blast Furnace Gas Cover • Casting Equipment • Construction Machinery • Container Spreader • Crane Wheel Bogie • Deck Cranes • EDS Scanner • Excavators • Fifth Wheel/Trailer Bogie • Gantry Cranes • Ladle Turrets • Machine Tools • Mechanical Engineering • Medical Equipment • Mixer • Mobile Cranes • Mooring station • Offshore Crane • Packaging or Bottling Equipment • Paddle Wheel Bearings • Ship Loader/Unloader • Solar Energy Plants • Special Sales • Stackers/Reclaimers • Swivel Bearings • Telescopes • Thruster • Tidal Energy Plants • Tower Cranes • Truck Mounted Cranes • Tunnel Boring Machines • Water Treatment Equipment • Wind Energy Plants

Series 23

Profile bearing

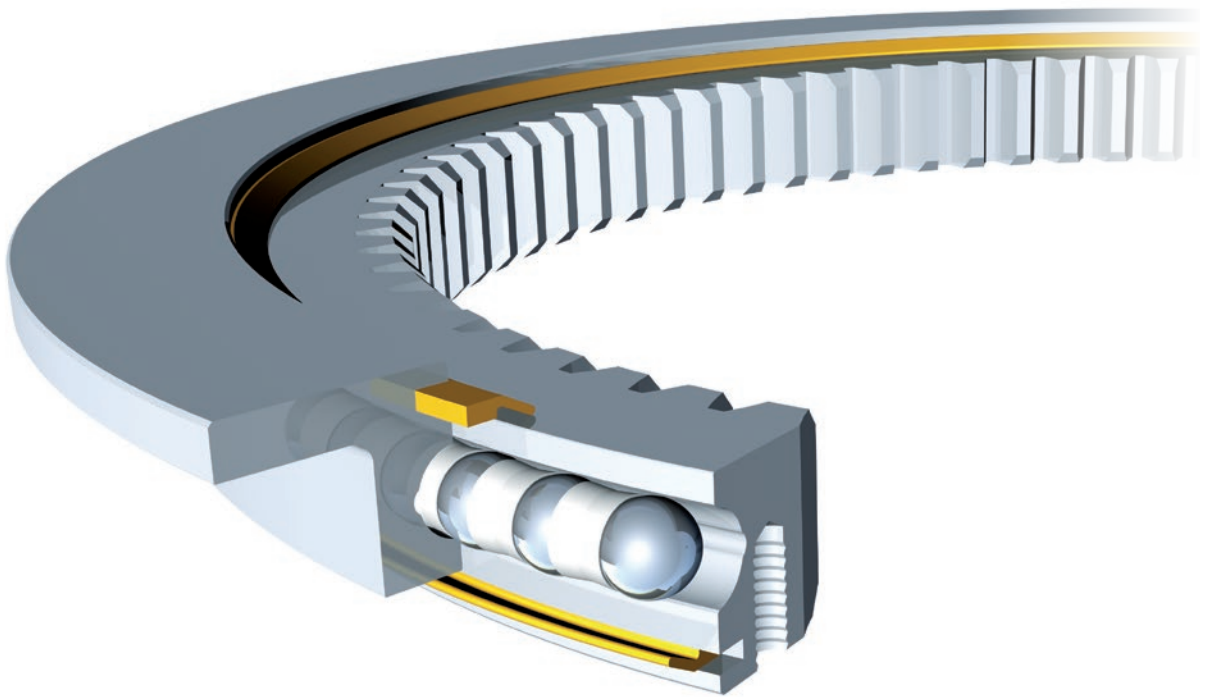

Gearing types

Bearings in Series 23 are supplied

- ⊖ without gearing
- ⊕ with external gearing
- ⊗ with internal gearing

Applications
series
23, 25, 28

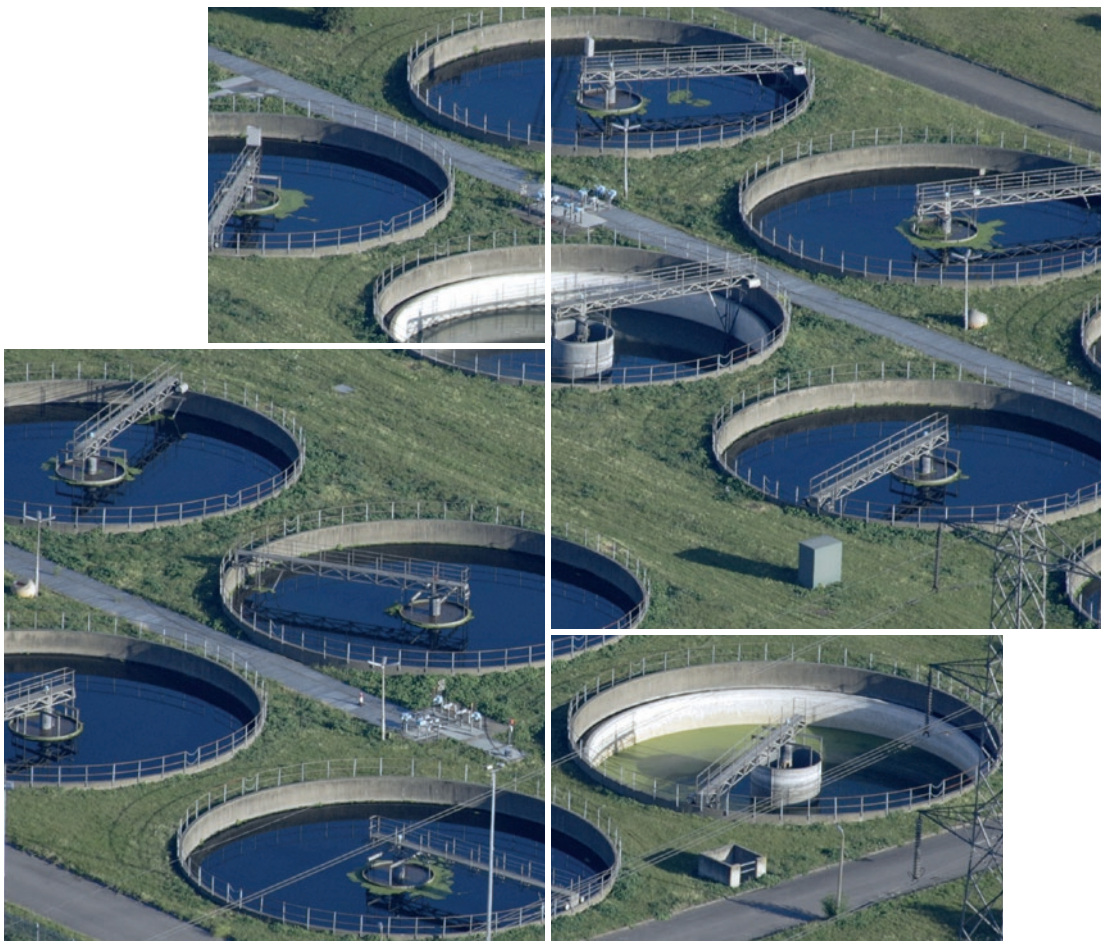

 Page 60
Page 76

Areas of application

Aerial Hydraulic Platforms • Antennas • Arc Furnaces • Band Conveyor • Blast Furnace Gas Cover • Casting Equipment • Construction Machinery • Container Spreader • Crane Wheel Bogie • Deck Cranes • EDS Scanner Excavators • Fifth Wheel/Trailer Bogie • Gantry Cranes • Ladle Turrets • Machine Tools • Mechanical Engineering Medical Equipment • Mixer • Mobile Cranes • Mooring station • Offshore Crane • Packaging or Bottling Equipment Paddle Wheel Bearings • Ship Loader/Unloader • Solar Energy Plants • Special Sales • Stackers/Reclaimers Swivel Bearings • Telescopes • Thruster • Tidal Energy Plants • Tower Cranes • Truck Mounted Cranes • Tunnel Boring Machines • Water Treatment Equipment • Wind Energy Plants

Series 25

Profile bearing

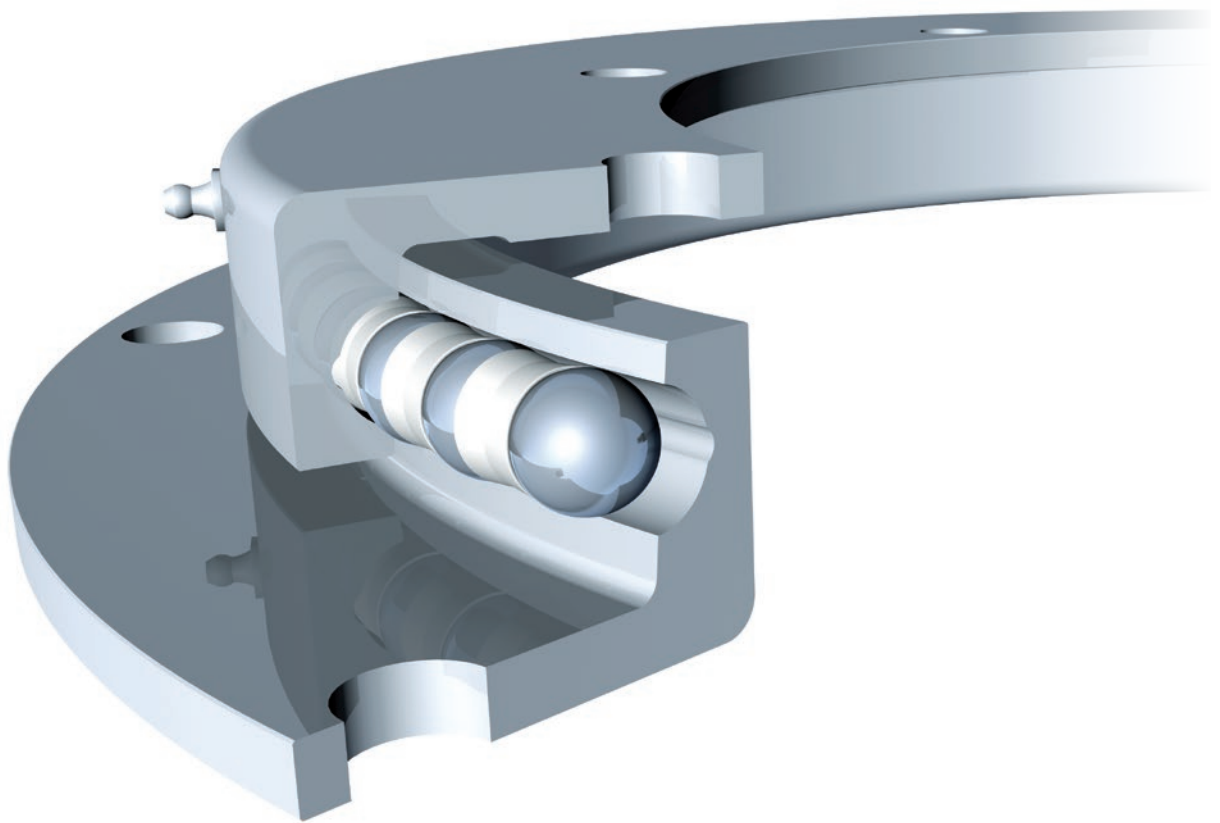

Gearing types

Bearings in Series 25 are supplied
⊖ without gearing

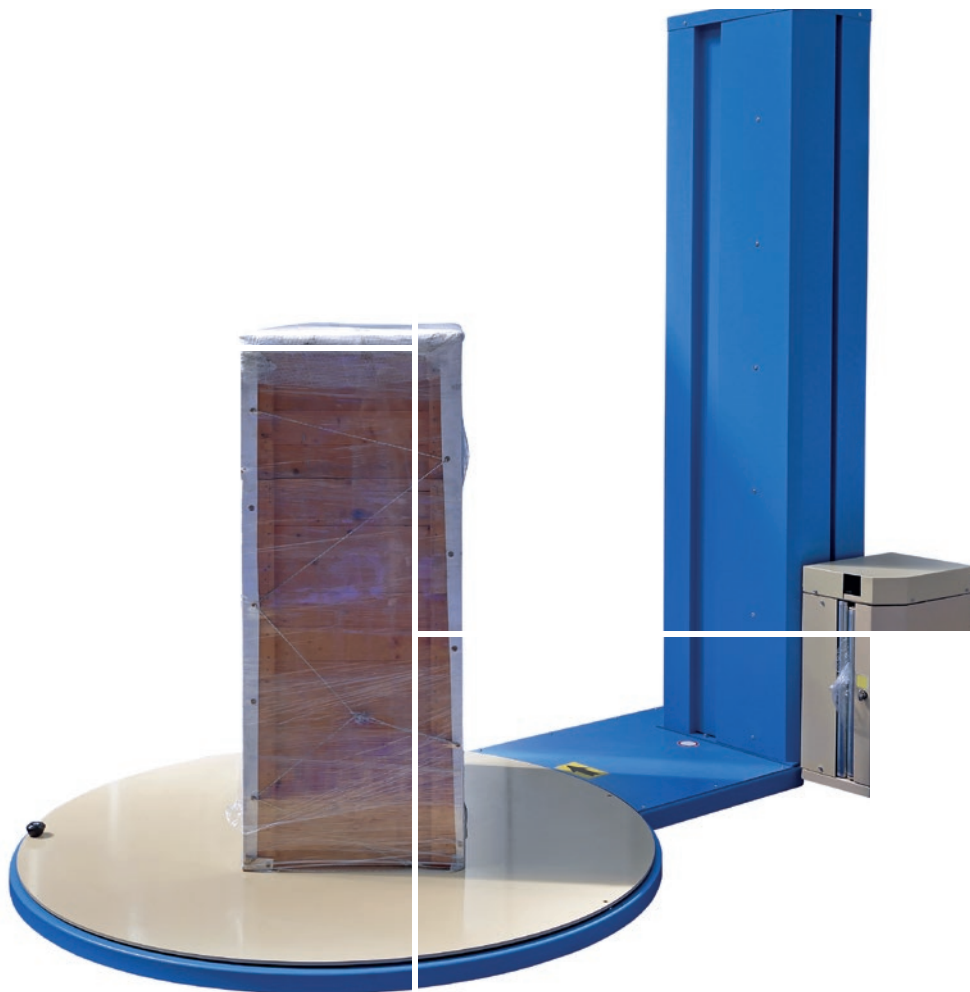

Applications
series
23, 25, 28



Page 60
Page 76

Areas of application

Aerial Hydraulic Platforms • Antennas • Arc Furnaces • Band Conveyor • Blast Furnace Gas Cover • Casting Equipment • Construction Machinery • Container Spreader • Crane Wheel Bogie • Deck Cranes • EDS Scanner Excavators • Fifth Wheel/Trailer Bogie • Gantry Cranes • Ladle Turrets • Machine Tools • **Mechanical Engineering** Medical Equipment • Mixer • Mobile Cranes • Mooring station • Offshore Crane • **Packaging or Bottling Equipment** Paddle Wheel Bearings • Ship Loader/Unloader • Solar Energy Plants • Special Sales • Stackers/Reclaimers Swivel Bearings • Telescopes • Thruster • Tidal Energy Plants • Tower Cranes • Truck Mounted Cranes • Tunnel Boring Machines • Water Treatment Equipment • Wind Energy Plants

Series 28

Profile bearing

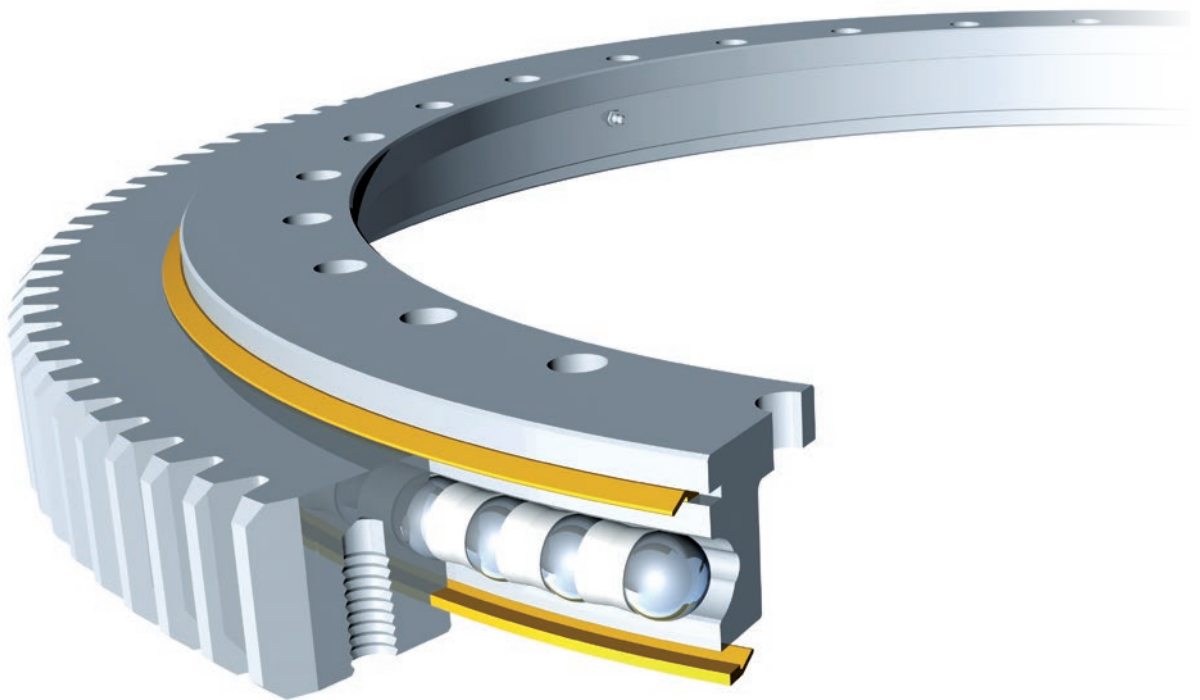

Gearing types

Bearings in Series 28 are supplied

- ⊖ without gearing
- ⊕ with external gearing
- ⊗ with internal gearing



Applications
series
23, 25, 28

 Page 60
Page 76

Areas of application

Aerial Hydraulic Platforms • Antennas • Arc Furnaces • Band Conveyor • Blast Furnace Gas Cover • Casting Equipment • Construction Machinery • Container Spreader • Crane Wheel Bogie • Deck Cranes • EDS Scanner Excavators • Fifth Wheel/Trailer Bogie • Gantry Cranes • Ladle Turrets • Machine Tools • **Mechanical Engineering** Medical Equipment • Mixer • Mobile Cranes • Mooring station • Offshore Crane • Packaging or Bottling Equipment Paddle Wheel Bearings • Ship Loader/Unloader • Solar Energy Plants • Special Sales • Stackers/Reclaimers Swivel Bearings • Telescopes • Thruster • Tidal Energy Plants • Tower Cranes • Truck Mounted Cranes • Tunnel Boring Machines • **Water Treatment Equipment** • Wind Energy Plants

Series 75

Single-row wire ball bearing

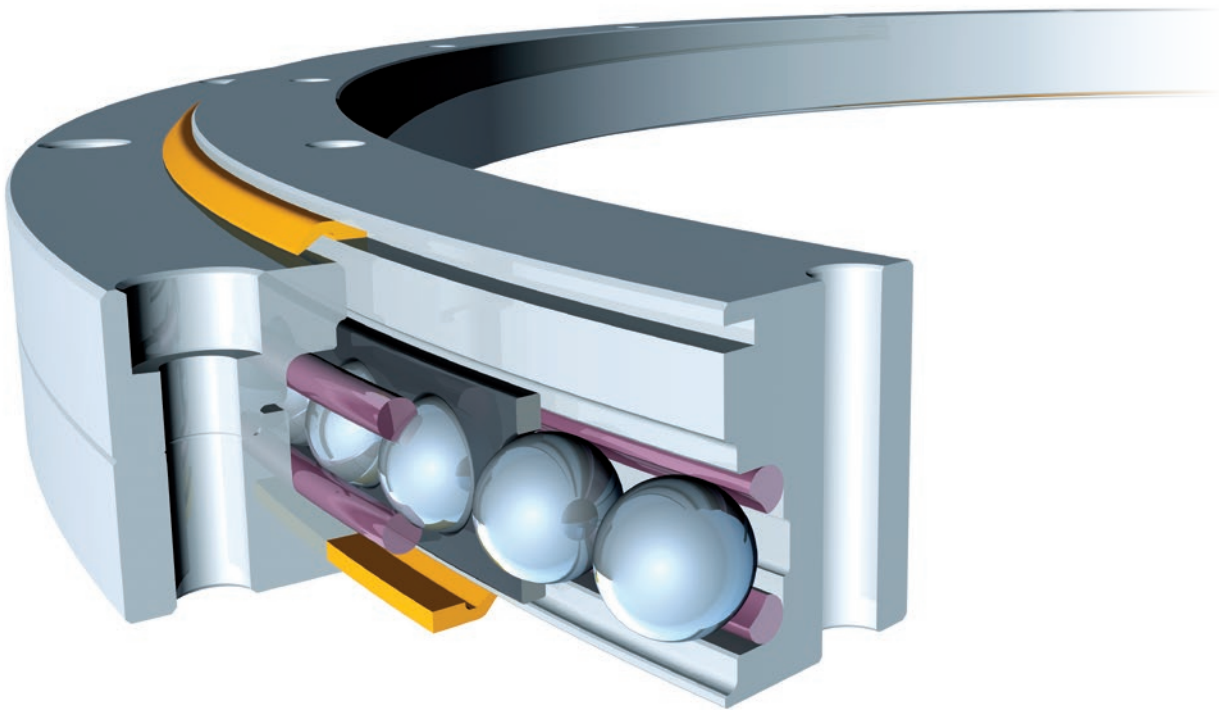

Gearing types

Bearings in Series 75 are supplied

- ⊖ without gearing
- ⊕ with external gearing
- ⊗ with internal gearing

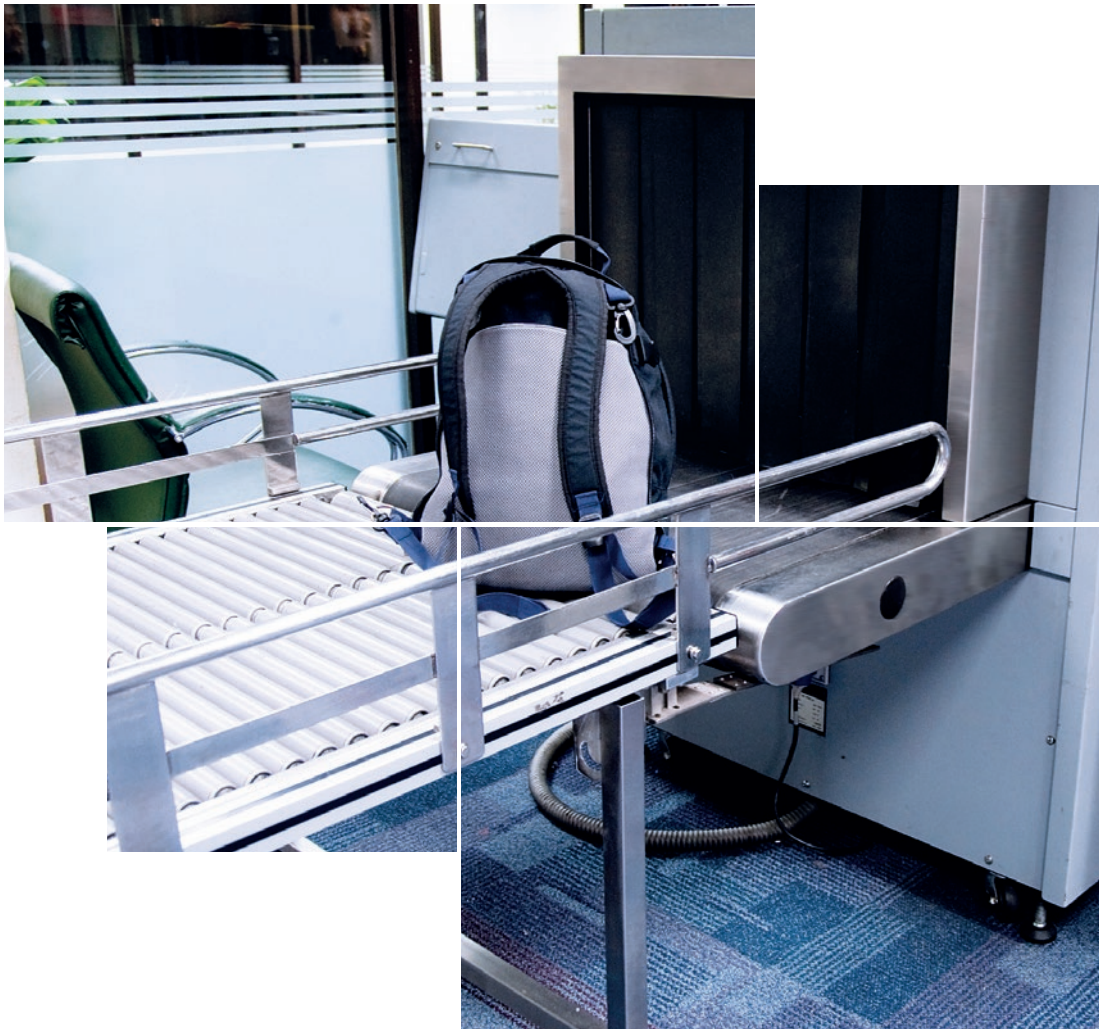

Applications
series
75, 80, 81, 87

Areas of application

Aerial Hydraulic Platforms • Antennas • Arc Furnaces • Band Conveyor • Blast Furnace Gas Cover • Casting Equipment • Construction Machinery • Container Spreader • Crane Wheel Bogie • Deck Cranes • **EDS Scanner** • Excavators • Fifth Wheel/Trailer Bogie • Gantry Cranes • Ladle Turrets • Machine Tools • Mechanical Engineering **Medical Equipment** • Mixer • Mobile Cranes • Mooring station • Offshore Crane • Packaging or Bottling Equipment • Paddle Wheel Bearings • Ship Loader/Unloader • Solar Energy Plants • **Special Sales** • Stackers/Reclaimers • Swivel Bearings • Telescopes • Thruster • Tidal Energy Plants • Tower Cranes • Truck Mounted Cranes • Tunnel Boring Machines • Water Treatment Equipment • Wind Energy Plants

Series 80

Segmented roller bearing with inserted races

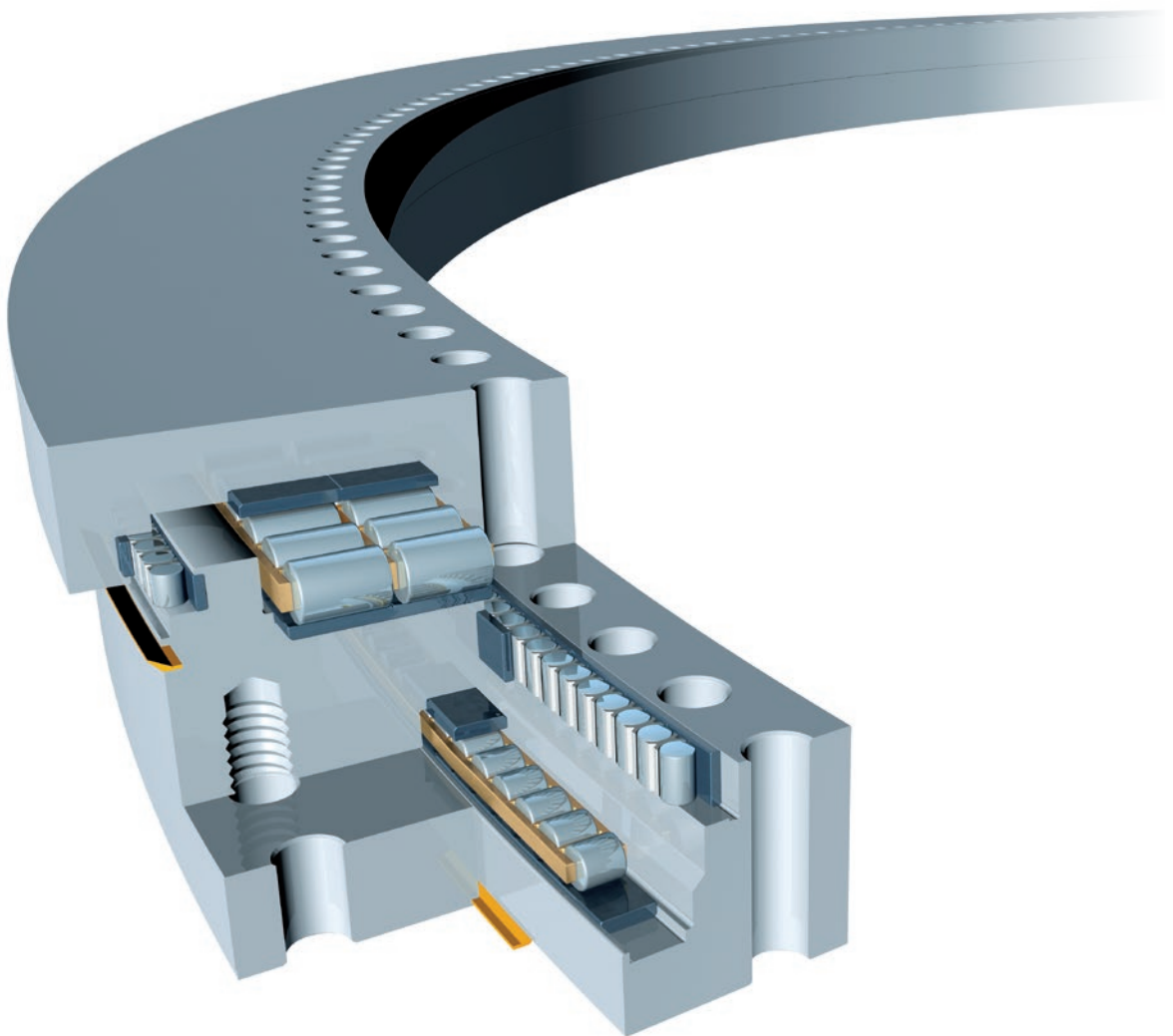

Gearing types

Bearings in Series 80 are supplied

- ⊖ without gearing
- ⊕ with external gearing
- ⊗ with internal gearing



© copyright Bluewater

Applications
series
75, 80, 81, 87

Areas of application

Aerial Hydraulic Platforms • Antennas • Arc Furnaces • Band Conveyor • Blast Furnace Gas Cover • Casting Equipment • Construction Machinery • Container Spreader • Crane Wheel Bogie • Deck Cranes • EDS Scanner Excavators • Fifth Wheel/Trailer Bogie • Gantry Cranes • Ladle Turrets • Machine Tools • Mechanical Engineering Medical Equipment • Mixer • Mobile Cranes • **Mooring station** • **Offshore Crane** • Packaging or Bottling Equipment Paddle Wheel Bearings • Ship Loader/Unloader • Solar Energy Plants • **Special Sales** • Stackers/Reclaimers Swivel Bearings • **Telescopes** • Thruster • Tidal Energy Plants • Tower Cranes • Truck Mounted Cranes • Tunnel Boring Machines • Water Treatment Equipment • Wind Energy Plants

Series 81

Double-row wire angular contact roller bearing

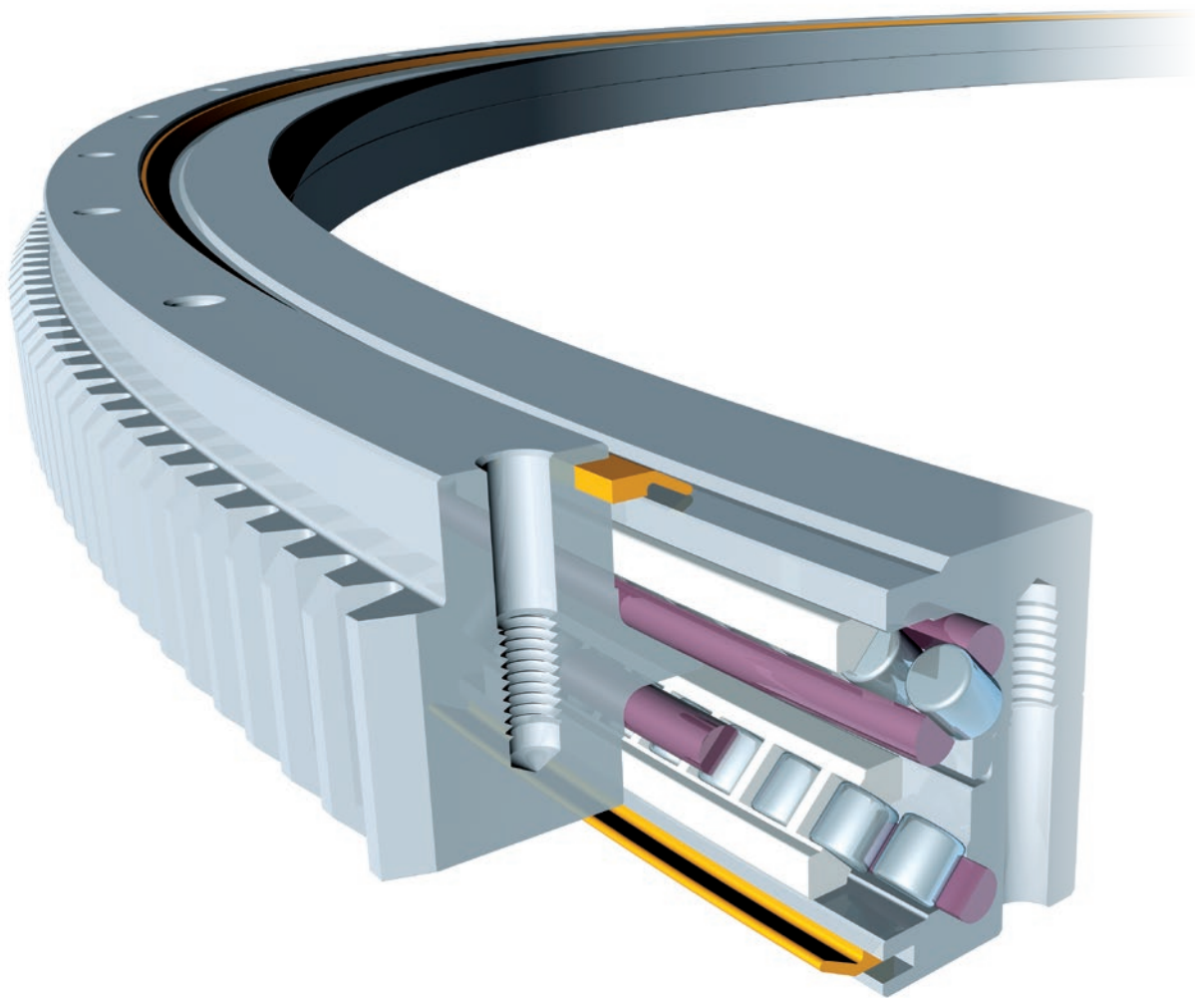

Gearing types

Bearings in Series 81 are supplied

- ⊖ without gearing
- ⊕ with external gearing
- ⊗ with internal gearing

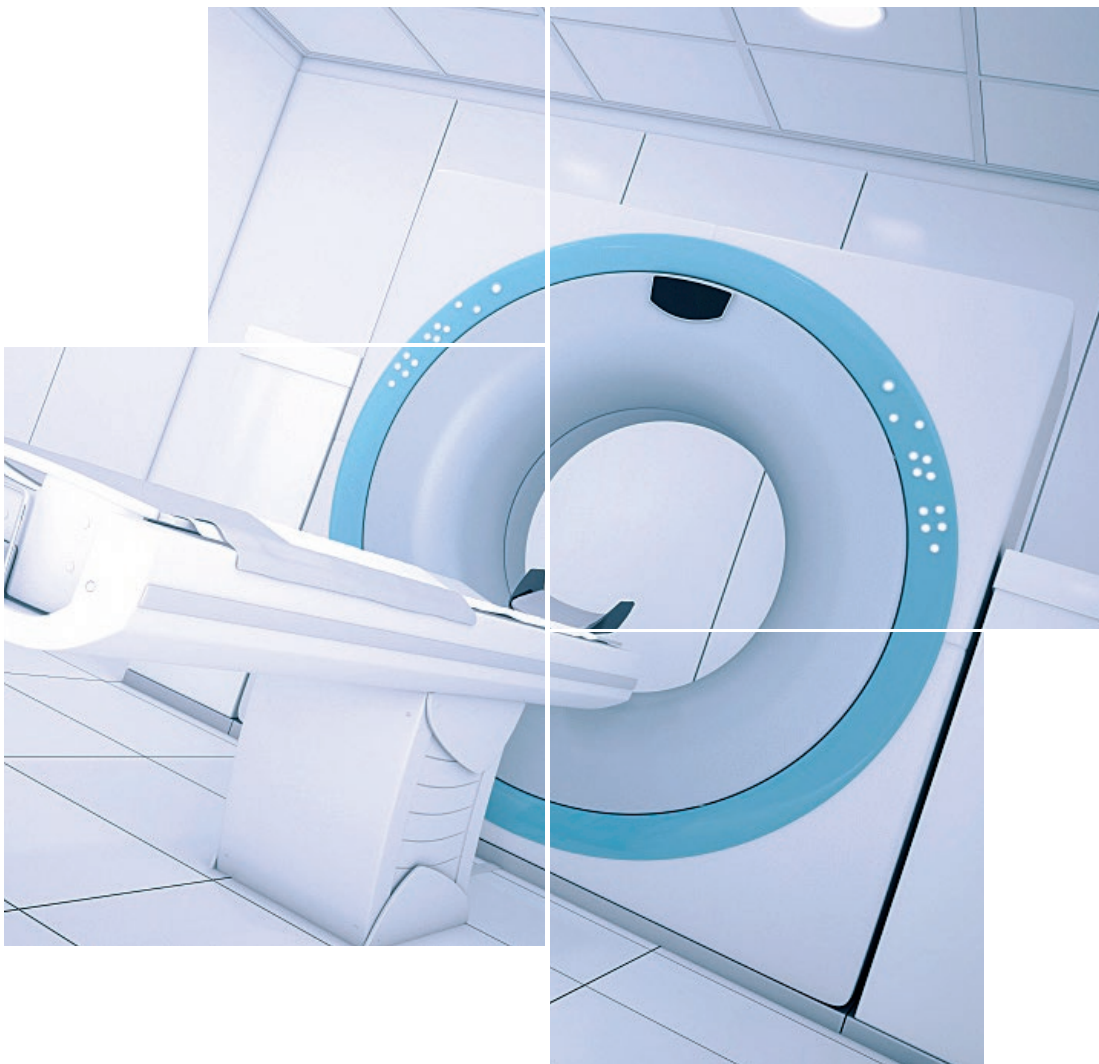

Applications
series
75, 80, 81, 87

Areas of application

Aerial Hydraulic Platforms • Antennas • Arc Furnaces • Band Conveyor • Blast Furnace Gas Cover • Casting Equipment • Construction Machinery • Container Spreader • Crane Wheel Bogie • Deck Cranes • EDS Scanner • Excavators • Fifth Wheel/Trailer Bogie • Gantry Cranes • Ladle Turrets • Machine Tools • Mechanical Engineering • **Medical Equipment** • Mixer • Mobile Cranes • Mooring station • Offshore Crane • Packaging or Bottling Equipment • Paddle Wheel Bearings • Ship Loader/Unloader • Solar Energy Plants • **Special Sales** • Stackers/Reclaimers • Swivel Bearings • Telescopes • Thruster • Tidal Energy Plants • Tower Cranes • Truck Mounted Cranes • Tunnel Boring Machines • Water Treatment Equipment • Wind Energy Plants

Series 87

Three-row wire roller bearing

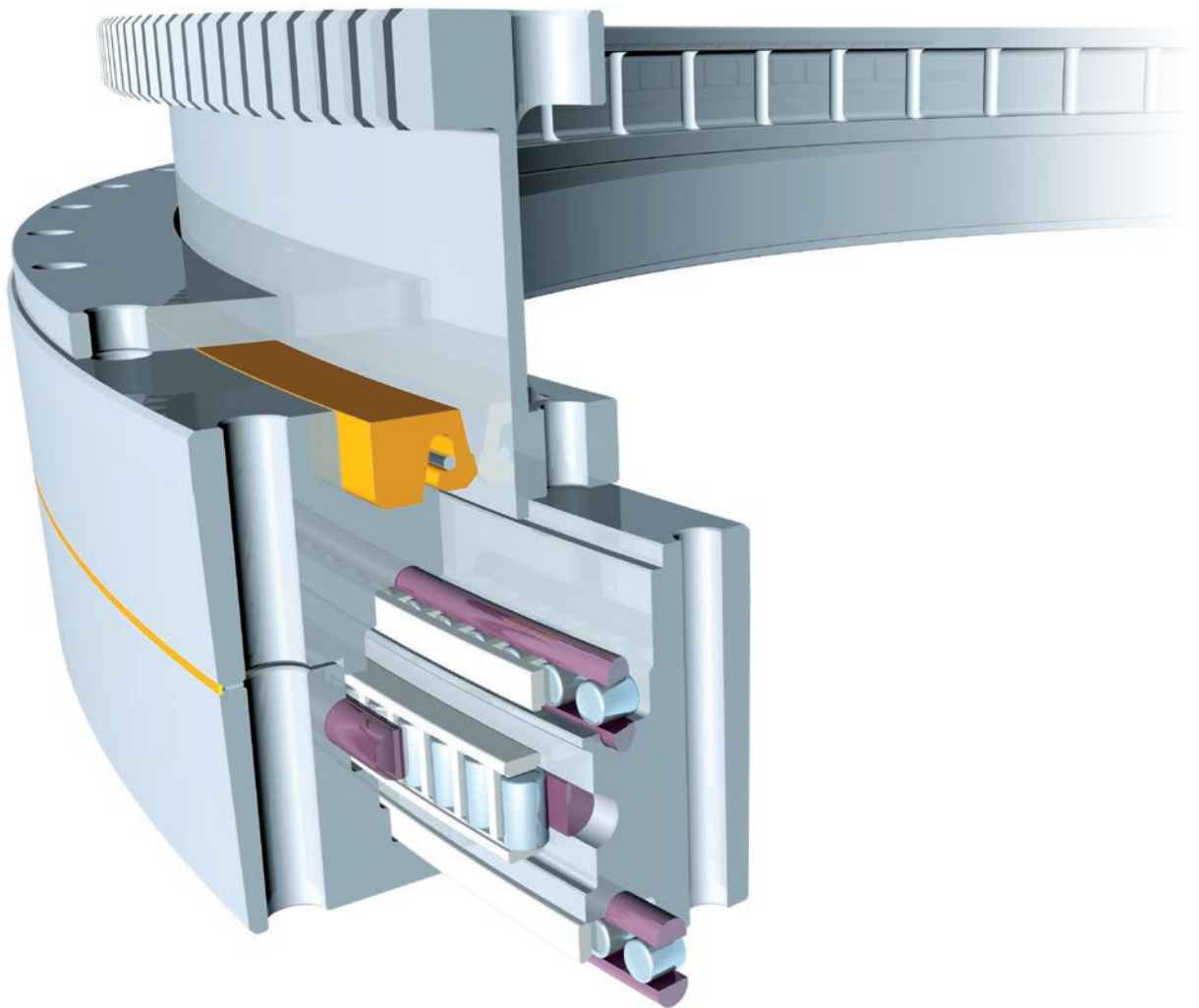

Gearing types

Bearings in Series 87 are supplied

- ⊖ without gearing
- ⊕ with external gearing
- ⊗ with internal gearing



Applications
series
75, 80, 81, 87

Areas of application

Aerial Hydraulic Platforms • Antennas • Arc Furnaces • Band Conveyor • Blast Furnace Gas Cover • Casting Equipment • Construction Machinery • Container Spreader • Crane Wheel Bogie • Deck Cranes • EDS Scanner Excavators • Fifth Wheel/Trailer Bogie • Gantry Cranes • Ladle Turrets • Machine Tools • Mechanical Engineering Medical Equipment • Mixer • Mobile Cranes • Mooring station • Offshore Crane • Packaging or Bottling Equipment Paddle Wheel Bearings • Ship Loader/Unloader • Solar Energy Plants • **Special Sales** • Stackers/Reclaimers Swivel Bearings • Telescopes • Thruster • Tidal Energy Plants • Tower Cranes • Truck Mounted Cranes • Tunnel Boring Machines • Water Treatment Equipment • Wind Energy Plants

Bearing selection in general

Bearing selection with catalog

This catalog cannot deal with all bearing properties, nor can it consider all selection criteria. Nevertheless, it covers a wide range of applications.

The slewing bearings contained in this catalog have boundary load curves allocated to them for static load capacity as well as utilization period curves.

To determine the necessary bearing load capacity, the loadings found must be multiplied by the „load factors“ listed in Table 1 for the various applications (excluding series 25 and series 23).

Advantage With the help of the catalog, bearing preselection for project planning is possible.

Note Those applications not listed must have comparable factors used for them depending on the operating mode.

Static load capacity

The loadings found are multiplied by factor f_{stat} , which is allocated to an application. The product F_a' or M_k' must be below the static boundary load curve of the selected bearing. With radial loads in load combinations

F_a = axial load
 F_r = radial load
 M_k = tilting moment

The „read-off loadings“ are found as an estimate for the „static“ bearing selection in type series 28, series 06 and series 09 as follows according to I and II:

Load combination I

$$F_a' = (F_a + 5,046 \cdot F_r) \cdot f_{stat}$$

$$M_k' = M_k \cdot f_{stat}$$

Load combination II

$$F_a' = (1,225 \cdot F_a + 2,676 \cdot F_r) \cdot f_{stat}$$

$$M_k' = 1,225 \cdot M_k \cdot f_{stat}$$

For series 25 and series 23, I and II apply as follows:

Load combination I

$$F_a' = (F_a + 5,046 \cdot F_r)$$

$$M_k' = M_k$$

Load combination II

$$F_a' = (1,225 \cdot F_a + 2,676 \cdot F_r)$$

$$M_k' = 1,225 \cdot M_k$$

The bearing is statically suitable if one of the two load combinations (I or II) is below the static boundary load curve.

The read-off load is determined for series 19 as follows:

$$F_a' = F_a \cdot f_{stat}$$

$$M_k' = M_k \cdot f_{stat}$$

The bearing is statically suitable if the load combination is below the static boundary load curve. In series 19, radial loads are not considered when reading off the boundary loads, and must be examined separately by thyssenkrupp rothe erde Germany GmbH.

Utilization period

The operating load multiplied by factor f_L is transferred to the utilization period curve where sensible.

If the expected utilization period differs from the parameter allocated to the factor or if a utilization period should be found using the duty cycle and time slices, see chapter „Utilization period“, pages 69 – 71.

Load factors for determining bearings Excluding series 25 and series 23

Table 1

Applications	f_{stat}	f_L	Utilization period Full load rotations
Floating crane (general cargo)	1,10	1,0	30000
Vehicle crane (general cargo)			
Deck crane (grapple)			
Welding turntable			
Turntable (continuous operation)			
Construction slewing cranes:	1,25	1,0	30000
Top slewing* $M_{kru} \leq 0,5 M_k$			
$0,5 M_k \leq M_{kru} \leq 0,8 M_k$			
$M_{kru} \geq 0,8 M_k$	1,15	45000	
Self-erecting crane	1,25	1,0	30000
Slewing crane (general cargo)	1,45**	1,7	150000
Shipyards crane			
Swiveling trolley (general cargo)			
Ship loader/unloader			
Smelting works crane	1,5	1,5	100000
Vehicle crane (grapple as well as operation with high handling capacity)			
Slewing crane (grapple/magnet)	1,7	1,7	150000
Swiveling trolley (grapple/magnet)			
Loading bridge (grapple/magnet)			
Floating crane (grapple/magnet)	2,15	2,15	300000
Bucket excavator			
Main slewing gear			
Back loader	1,45**	1,7	150000
Spreader			
Jib conveyor			
Offshore crane	Configuration according to special regulations		
Railway crane	1,10	Configuration according to special regulations	
Deck crane (general cargo)	1,00		
Spreader	1,10		
Jib conveyor			
Conveyor trolley			
Crawler crane/dragline bucket	1,25		
Slewing dredge			
Hydraulic excavator: up to 1.5 m ³	1,45		
above 1.5 m ³			
Casting ladle trolley	1,75		

For static configuration, the maximum loadings that occur including the additional and test loads that arise must always be taken into account.

The static safety factors (f_{stat} , e.g. erecting loads, higher test loads, etc.) are only allowed to be undershot in exceptional circumstances – subject to prior written approval from us.

The listed values f_L relate to a configuration with maximum operating load, and have been derived from practical experience and test rig tests. When determining the necessary number of full-load rotations, if a duty cycle with assumed average loading is considered, then correspondingly higher utilization period values are to be set.

In applications that are not listed in the table, the reference values for similar operating conditions can be used as far as sensible.

*) Construction swiveling cranes top slewing
 M_{kru} = Turning-back torque without load
 M_k = Moment at max. projection with load

***) For applications with a required configuration of
 $f_{stat} = 1.45$, multi-roll bearing versions are to be preferred because the average loading is usually higher and operation is under harsher conditions.

Remark:
 For these applications, the operating conditions, especially the on-time of the slewing mechanism and the loadings when slewing are highly diverse. This means a static configuration can be made for occasional slewing movements, e.g. setting to a working position. Otherwise, for continuous rotation or slewing, configuration according to the utilization period is a sensible option. The latter may also be necessary if the bearing is to carry out relative movements such as those of discharge jib conveyors on bucket wheel devices.

Load transmission

rothe erde® slewing bearings are ready-to-install machinery elements for simultaneously transmitting axial and radial forces, as well as the resulting tilting moments.

Installation situation on surface

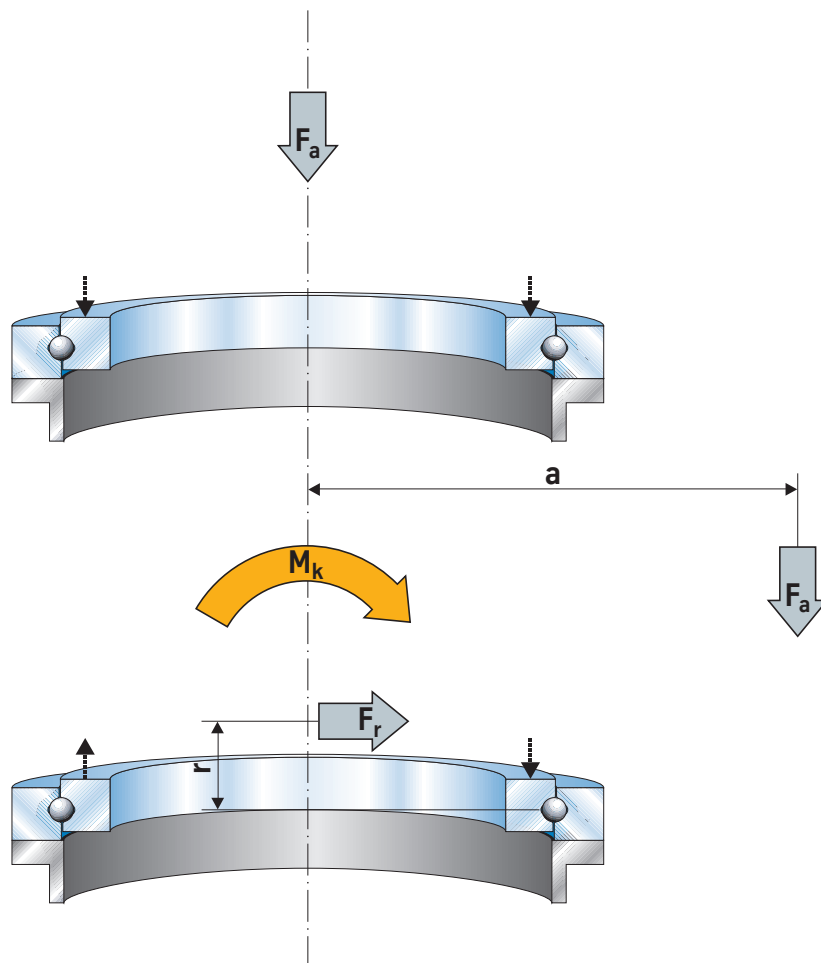
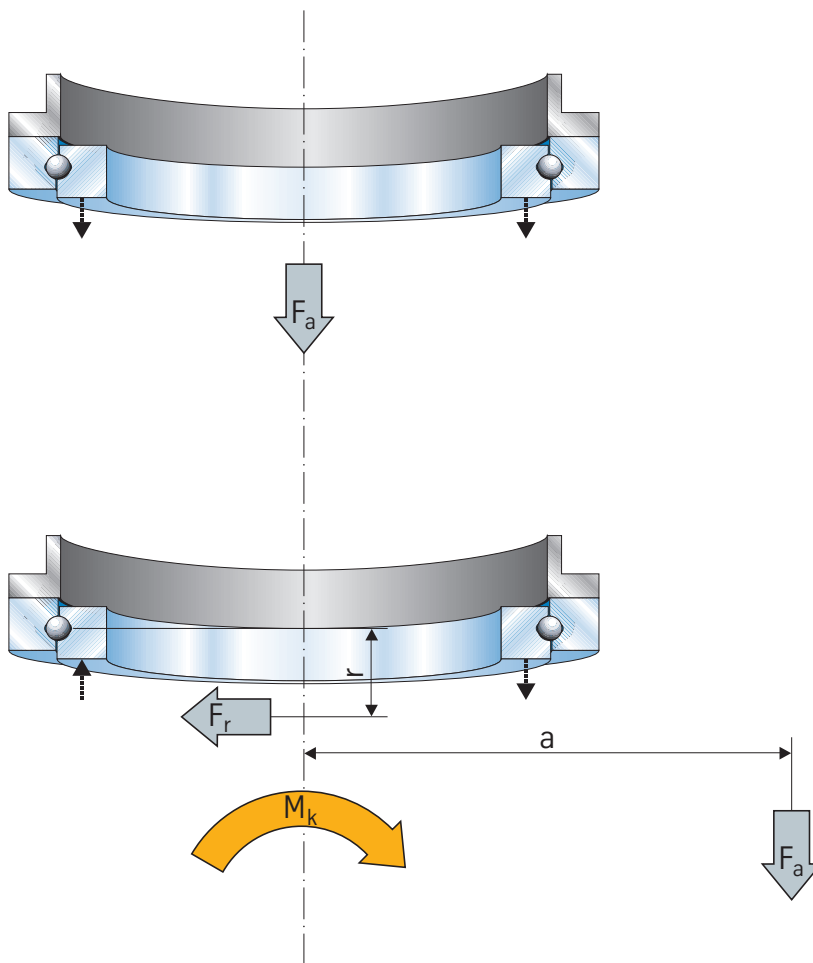

Figure 1

The boundary load curves cannot be used with suspended installation. An increased number of bolts are required. We perform the configuration.

Installation situation suspended



Calculation

Figure 2

Inquiry data

Optimum solution

Each application has its individual requirements for which a quite specific slewing bearing is particularly suitable. When selecting the bearing, it is thus necessary to consider many boundary conditions such as installation space, load capacity, service life, sealing, etc. The best possible solution will be found in close cooperation between the customer and thyssenkrupp rothe erde Germany GmbH.

The selection involves finding the correct dimensions of the bearing raceways, gearing and bolted connection.

Correct decisions are based on correct information. For the ideal bearing selection, it is thus necessary for you to provide us with the facts we need via the enquiry data sheet.

Figure 3, right side The most important data for the bearing selection is

- Application
- Loadings for raceway and bolts
- Gearing loadings
- Installation space
- Operating conditions

Advantage By you filling in the enquiry data sheet in full, we are able to address your wishes and work out the most suitable bearing proposal in terms of technology and economic efficiency.

Note Please fill in the relevant attachments as well with regard to service life requirements as well as if you have further specifications relating to the gearing. These can be found with the enquiry data at www.thyssenkrupp-rotheerde.com

rothe erde® slewing bearings Questionnaire



Company _____
 Name _____ Department _____
 Address _____ Phone _____
 _____ e-mail _____
 Country _____ Date _____
 Project name _____

Application

Axis of rotation
 horizontal vertical alternating

Application of load (please put a cross at the applicable point)

Movement
 positioning only
 slewing
 rotation

Slewingrange _____ [°]

No. of revolutions [min⁻¹]
 normal
 maximal

Bearing loads

Load information according to system of coordinates in relation to the rotating ring

Please note the sign with regard to the load information

		max. working load	max. test load e.g. 25% overload condition	Extreme load e.g. shocks or out of operation	
Axial loads	F_z				[kN]
Radial loads	F_x				[kN]
	F_y				
Tilting moment	M_x				[kNm]
	M_y				
Bearing turning torque	M_z normal				[kNm]
	M_z max.				
Bearing in various load situations		<input type="checkbox"/> rotating	<input type="checkbox"/> rotating	<input type="checkbox"/> rotating	
		<input type="checkbox"/> stationary	<input type="checkbox"/> stationary	<input type="checkbox"/> stationary	

No. of drives _____ Please mark the positions of the drives in sketch (Appendix B)

Gear without external internal

Existing or chosen bearing per drawing No.: _____

For continuous rotation, variable and B10 life requirements, please complete annex A. Annex A is enclosed.

Remarks:

- e.g. special environmental conditions as there are corrosive media, dirt, temperatures others than standard (-20°C up to +60°C) etc.
- e.g. special bearing dimensioning with regard to precisions, acceptance conditions, material testings, dimensions etc.

Please fully complete this form. Incomplete information will delay processing and impede profitable technical preparation.

Individual technical consultation required. Please call for appointment.

Date _____

Calculation

Example of a bearing selection for a slewing crane

The maximum load must be determined according to the following formulas.

The calculated loadings must be multiplied by the load factors prior to bearing selection (Table 1, page 61).

For the examples in this case:

General cargo operation

Load factor $f_{stat} = 1.25$

Grapple operation

Load factor $f_{stat} = 1.45$



Bild 4

1. Lifting load with maximum projection

1.1 Maximum operating load including wind:

$$\text{Axial load } F_a = Q_1 + A + O + G$$

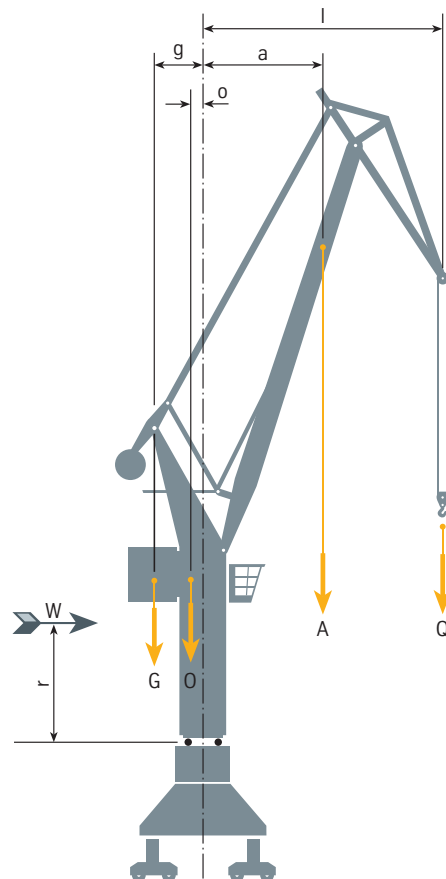
$$\text{Res. moment } M_k = Q_1 \cdot l_{max} + A \cdot a_{max} + W \cdot r - O \cdot o - G \cdot g$$

1.2 Loading including 25% lifting load increase without wind:

$$\text{Axial load } F_a = 1.25 \cdot Q_1 + A + O + G$$

$$\text{Res. moment } M_k = 1.25 \cdot Q_1 \cdot l_{max} + A \cdot a_{max} - O \cdot o - G \cdot g$$

2. Lifting load with smallest projection

2.1 Maximum operating load including wind:

$$\text{Axial load } F_a = Q_2 + A + O + G$$

$$\text{Res. moment } M_k = Q_2 \cdot l_{min} + A \cdot a_{min} + W \cdot r - O \cdot o - G \cdot g$$

2.2 Loading including 25% lifting load increase without wind:

$$\text{Axial load } F_a = 1.25 \cdot Q_2 + A + O + G$$

$$\text{Res. moment } M_k = 1.25 \cdot Q_2 \cdot l_{min} + A \cdot a_{min} - O \cdot o - G \cdot g$$

Example 1

Slewing crane for general cargo operation

With maximum projection

Q	= 220 kN	l_{max}	= 23,00 m
A	= 75 kN	a_{max}	= 11,00 m
O	= 450 kN	o	= 0,75 m
G	= 900 kN	g	= 3,00 m
W	= 27 kN	r	= 6,50 m

1. Maximum operating load including wind

$$F_a = Q + A + O + G$$

$$= 220 + 75 + 450 + 900$$

$$F_a = 1645.0 \text{ kN}$$

$$M_k = Q \cdot l_{max} + A \cdot a_{max} + W \cdot r - O \cdot o - G \cdot g$$

$$= 220 \cdot 23 + 75 \cdot 11 + 27 \cdot 6.5 - 450 \cdot 0.75 - 900 \cdot 3$$

$$M_k = 3023.0 \text{ kNm}$$

2. Load case incl. 25% lifting load increase without wind

$$F_a = Q \cdot 1.25 + A + O + G$$

$$= 275 + 75 + 450 + 900$$

$$F_a = 1700.0 \text{ kN}$$

$$M_k = Q \cdot 1.25 \cdot l_{max} + A \cdot a_{max} - O \cdot o - G \cdot g$$

$$= 275 \cdot 23 + 75 \cdot 11 - 450 \cdot 0.75 - 900 \cdot 3$$

$$M_k = 4112.5 \text{ kNm}$$

3. Maximum operating load without wind

$$F_a = 1645.0 \text{ kN}$$

$$M_k = Q \cdot l_{max} + A \cdot a_{max} - O \cdot o - G \cdot g$$

$$= 220 \cdot 23 + 75 \cdot 11 - 450 \cdot 0.75 - 900 \cdot 3$$

$$M_k = 2847.5 \text{ kNm}$$

When selecting the bearing, load case 2 should be used for static evaluation and load case 3 for the utilization period.

The static bearing load capacity is checked taking account of the load factor $f_{stat} = 1.25$ against the "static boundary load curve" with the read-off loading
 Load case 2: $F_a' = 1700 \text{ kN} \cdot 1.25 = 2125.0 \text{ kN}$
 $M_k' = 4112.5 \text{ kNm} \cdot 1.25 = 5140.6 \text{ kNm}$

For a utilization period of 45 000 full-load rotations, a load factor $f_L = 1.15$ is to be used, read-off loading:
 Load case 3: $F_a' = 1645 \text{ kN} \cdot 1.15 = 1891.7 \text{ kN}$
 $M_k' = 2847.5 \text{ kNm} \cdot 1.15 = 3274.6 \text{ kNm}$

Number of bolts and strength class are defined for the maximum loadings without factor:
 Load case 2: $F_a = 1700.0 \text{ kN}$
 $M_k = 4112.5 \text{ kNm}$

Example 2

Slewing crane for grapple operation

With maximum projection

Q	= 180 kN	l_{max}	= 19,00 m
A	= 110 kN	a_{max}	= 9,00 m
O	= 450 kN	o	= 0,75 m
G	= 900 kN	g	= 3,00 m
W	= 27 kN	r	= 6,50 m

1. Maximum operating load including wind

$$F_a = Q + A + O + G$$

$$= 180 + 110 + 450 + 900$$

$$F_a = 1640.0 \text{ kN}$$

$$M_k = Q \cdot l_{max} + A \cdot a_{max} + W \cdot r - O \cdot o - G \cdot g$$

$$= 180 \cdot 19 + 110 \cdot 9 + 27 \cdot 6.5 - 450 \cdot 0.75 - 900 \cdot 3$$

$$M_k = 1548.0 \text{ kNm}$$

2. Load case incl. 25% lifting load increase without wind

$$F_a = Q \cdot 1.25 + A + O + G$$

$$= 225 + 110 + 450 + 900$$

$$F_a = 1685.0 \text{ kN}$$

$$M_k = Q \cdot 1.25 \cdot l_{max} + A \cdot a_{max} - O \cdot o - G \cdot g$$

$$= 225 \cdot 19 + 110 \cdot 9 - 450 \cdot 0.75 - 900 \cdot 3$$

$$M_k = 2227.5 \text{ kNm}$$

3. Maximum operating load without wind

$$F_a = 1640.0 \text{ kN}$$

$$M_k = Q \cdot l_{max} + A \cdot a_{max} - O \cdot o - G \cdot g$$

$$= 180 \cdot 19 + 110 \cdot 9 - 450 \cdot 0.75 - 900 \cdot 3$$

$$M_k = 1372.5 \text{ kNm}$$

In the bearing selection, load case 2 must be used for the static dimension selection and load case 3 for the utilization period.

The static bearing load capacity is checked taking account of the load factor $f_{stat} = 1.45$ against the "static boundary load curve" with the read-off loading
 Load case 2: $F_a' = 1685 \text{ kN} \cdot 1.45 = 2443.3 \text{ kN}$
 $M_k' = 2227.5 \text{ kNm} \cdot 1.45 = 3230.0 \text{ kNm}$

For a utilization period of 150 000 full-load rotations, a load factor $f_L = 1.7$ is to be used, read-off loading:
 Load case 3: $F_a' = 1640 \text{ kN} \cdot 1.7 = 2788.0 \text{ kN}$
 $M_k' = 1372.5 \text{ kNm} \cdot 1.7 = 2333.3 \text{ kNm}$

Number of bolts and strength class are defined for the maximum loadings without factor:
 Load case 2: $F_a = 1685.0 \text{ kN}$
 $M_k = 2227.5 \text{ kNm}$

Example of a bearing selection for a slewing crane

Pre-selection of the bearing using boundary load and utilization period curves. The read-off load must be below the particular curve. Entered read-off loadings in general cargo operation (blue), grapple operation (orange). For the aforementioned load cases, it is possible to select:

- Bearing **3** for general cargo operation
- Bearing **3** for grapple operation (due to the utilization period curve)

Static boundary load curves

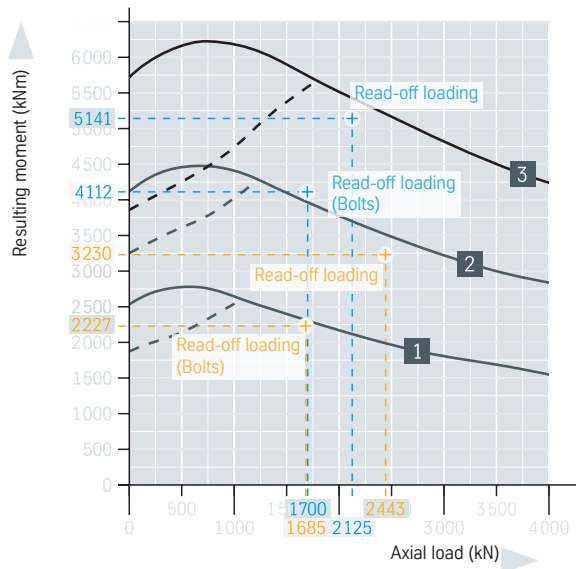
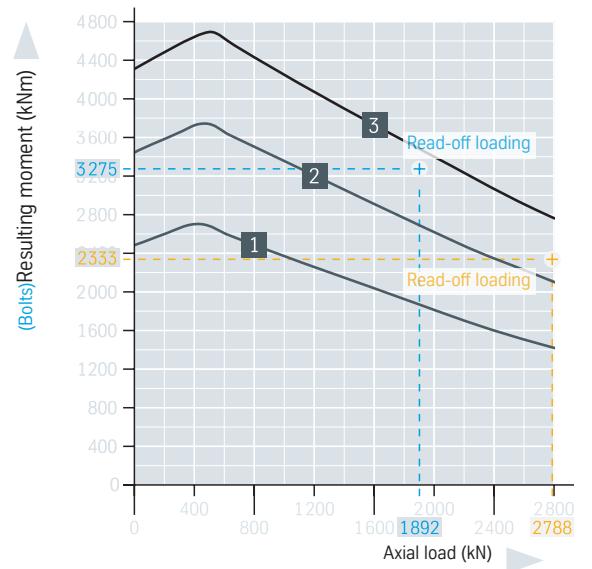

Figure 5

Utilization period curves · 30 000 revolutions



- Bearing **6** for general cargo operation
- Bearing **5** for grapple operation

Static boundary load curves

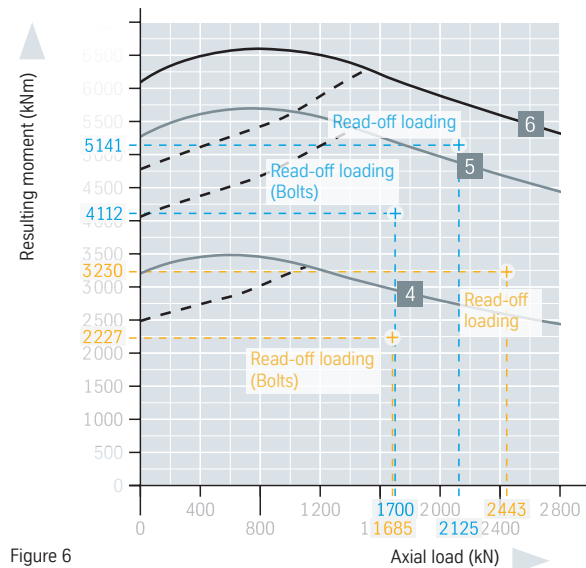
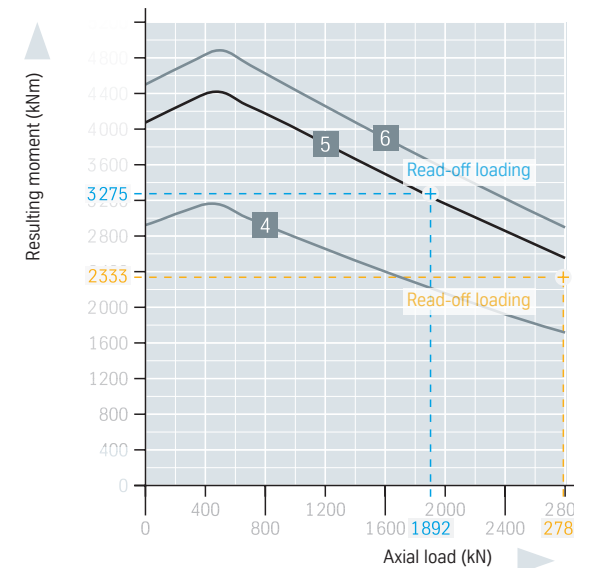

Figure 6

Utilization period curves · 30 000 revolutions



Utilization period

Establishing the correct dimensions

thyssenkrupp rothe erde Germany GmbH exclusively offers its customers solutions with utilization periods optimally adapted to the requirements of the application.

The term “utilization period” is used in roller bearing technology because the theoretical service life cannot be used as an absolute value in practical applications due to the varied influencing parameters – according to DIN ISO 281 or DIN 26281 – but only represents a comparison value and configuration parameter. It is not necessarily the case that all bearings will achieve the theoretical service life, although the majority of them will exceed it as a rule, and in some cases many times over.

Slewing bearings – especially those for slewing or slow rotational movements – can only have the criteria of the theoretical service life applied to them to a limited extent. Usually, the circumferential velocity is low, meaning that smooth running and accuracy are not disruptively influenced by wear or individual cases of pitting.

As a result, it is usual for slewing bearings used in slewing and slowrotational movements to be dimensioned according to utilization period rather than theoretical service life. This is achieved if the rotational resistance increases progressively or the wear has advanced to such an extent that the function of the bearing longer functions (see bearing inspection on pages 232–239).

Slewing bearings are used under a wide variety of operating conditions. Depending on the operating mode, e.g. variable slewing movements or continuous rotation, it is not only necessary to select according to static aspects but also based on the expected utilization period from the dynamic loading.

In this case, it is necessary to differentiate consistently between the operating hours of the equipment and the actual rotation or slewing time. The various loadings are taken into account in duty cycles and proportions. In addition, the slewing angle with or without load is not allowed to be neglected as an influencing parameter.

In order to establish the approximate utilization period, it is possible to use the static boundary load diagrams and also the “utilization period curves”. For profile bearings in series 25 and series 23, the configuration is only static.

These curves are based on the assumption of 30000 rotations under full load. They can – as described below – be used for calculating a utilization period for different duty cycles or for selecting a bearing with a specified utilization period.

The utilization period identified and represented with the help of curves is only to be used for bearings with slewing and slow rotational movements. This procedure cannot be used for, for example

- Bearings for withstanding high radial forces
- Bearings with high rotational speeds and
- Bearings that have to achieve high accuracy requirements.

In such cases, the calculation is performed by thyssenkrupp rothe erde Germany GmbH on the basis of the duty cycle with corresponding rotation speed and proportions of the on-time.

Calculation

$$f_L = \frac{F_{a0}}{F_a} = \frac{M_{k0}}{M_k}$$

$$G = (f_L)^p \cdot 30\,000$$

Used Formula symbols	unit	
G	U	Utilization period in rotations
G ₁ ; G ₂ ; ...G _i	U	Utilization period for duty cycles 1; 2; ...i
F _a	kN	Axial load
M _k	kNm	Tilting moment
F _{a0}	kN	Axial load on the curve
M _{k0}	kNm	Resulting tilting moment on the curve
F _a '	kN	"Read-off loading" calculated with f _L
M _k '	kNm	"Read-off loading" calculated with f _L
F _{am}	kN	Average axial load
M _{km}	kNm	Average tilting moment
ED ₁ ; ED ₂ ; ...ED _i	%	Proportion of the operating time in %
p		Exponent
		Ball bearing p = 3
		Roller bearing p = 10/3
f _L		Ratio of the loads to the curve (load factor) [1]

Sample calculation for utilization period

Example 1

The bearing is loaded with $F_a = 1250$ kN and $M_k = 2000$ kNm.
What is the expected utilization period?

Utilization period curves · 30 000 revolutions

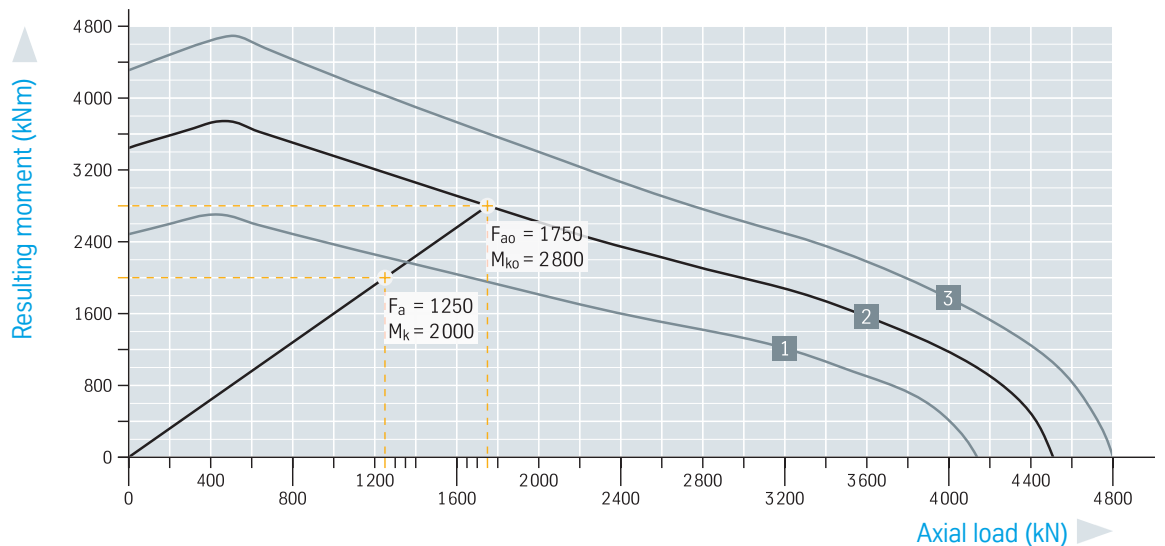

Figure 7

The known load case $F_a; M_k$ is entered in the relevant diagram. The line from the origin of the diagram through the specified load case intersects the curve of the bearing, in this example bearing 2, at the point $(F_{a0}; M_{k0})$.

Based on this, formulas [1] and [2] are

used for calculating the expected utilization period:

$$f_L = \frac{F_{a0}}{F_a} = \frac{M_{k0}}{M_k} \quad [1]$$

$$f_L = \frac{1750}{1250} = \frac{2800}{2000} = 1,4$$

$$G = (f_L)^3 \cdot 30000 \quad [2]$$

$$G = 1,4^3 \cdot 30000 = 82320 \text{ rotations}$$

The application time can be calculated by converting from slewing or rotation angles per unit of time.

Note If several different load combinations can be defined, proceed according to example 2 for calculating the expected utilization period.

Example 2

The following duty cycles should be given for the bearing 2 dealt with in example 1. What is the expected total utilization period?

Utilization period curves · 30 000 revolutions

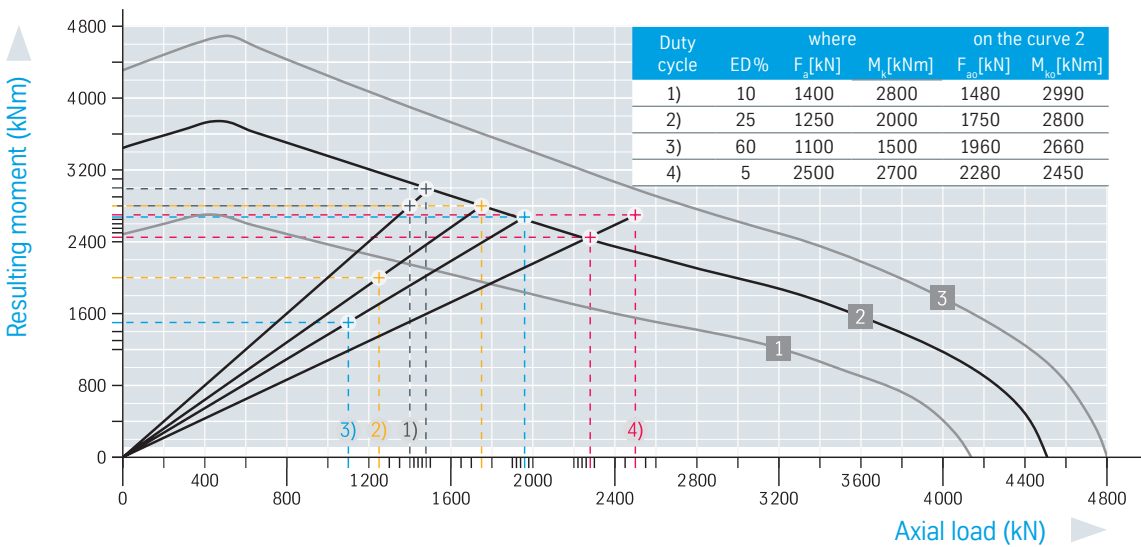

Figure 8

According to the representation above, a utilization period $G_{1;2;...;i}$ is calculated for each load case. These values are summarized with formula [3] and the proportions given for the individual load cases to make a total utilization period.

$$1) f_L = \frac{2990}{2800} \sim \frac{1480}{1400} \sim 1,06$$

$$2) f_L = \frac{2800}{2000} \sim \frac{1750}{1250} \sim 1,40$$

$$3) f_L = \frac{2660}{1500} \sim \frac{1960}{1100} \sim 1,78$$

$$4) f_L = \frac{2450}{2700} \sim \frac{2280}{2500} \sim 0,91$$

$$G_{ges} = \frac{100}{\frac{ED_1}{G_1} + \frac{ED_2}{G_2} + \dots + \frac{ED_i}{G_i}} \quad [3]$$

Summary

$$G_1 = 1,06^3 \cdot 30\,000 = 35\,730 \text{ U; } ED_1 = 10\%$$

$$G_2 = 1,40^3 \cdot 30\,000 = 82\,320 \text{ U; } ED_2 = 25\%$$

$$G_3 = 1,77^3 \cdot 30\,000 = 166\,360 \text{ U; } ED_3 = 60\%$$

$$G_4 = 0,91^3 \cdot 30\,000 = 22\,607 \text{ U; } ED_4 = 5\%$$

$$G_{ges} = \frac{100}{\frac{10}{35\,730} + \frac{25}{82\,320} + \frac{60}{166\,360} + \frac{5}{22\,607}} = 85\,807 \text{ rotations}$$

Innovative calculation of slewing bearings

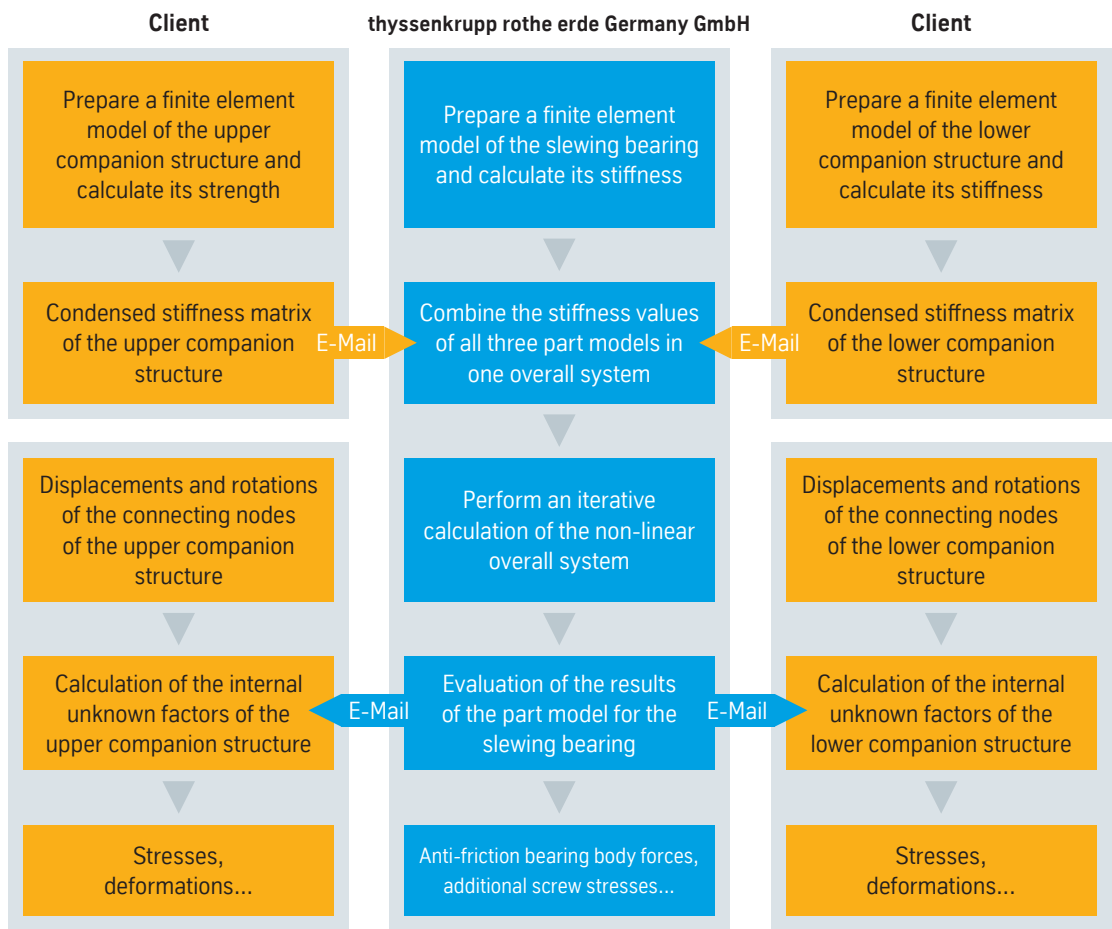

Figure 9: Flowchart for the calculation process developed at thyssenkrupp rothe erde Germany GmbH

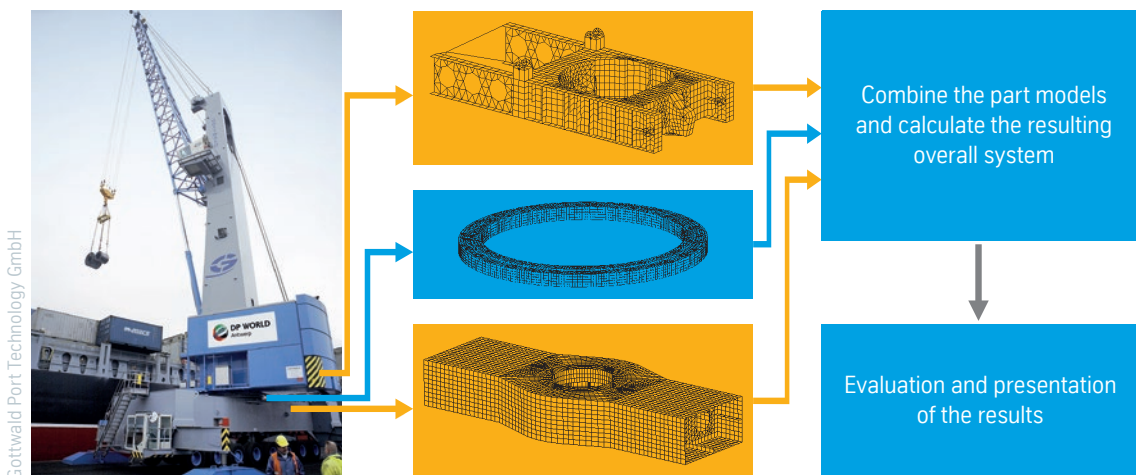

Figure 10: Schematic process

Improved processes

You exclusively model and analyze your own component. thyssenkrupp rothe erde Germany GmbH links your calculated component properties of the companion structure to the calculation model of the slewing bearing to produce a comprehensive finite element model. Following that, our insights regarding the slewing bearing influence allow you to optimize your companion structure.

Advantage Cost saving due to computer simulations and reduced processing complexity on our part by up to 90% in comparison.

Note By providing the calculation process that we have developed, combined with our specific expertise, you have the opportunity to benefit from a sustainable development partnership.

Perfected process

For developing the ideal slewing bearing, it is of enormous importance to be able to determine the various loadings such as stress and deformation values precisely which occur in connection with the companion structure.

This is precisely what our innovative calculation process does. For the first time, it enables you to calculate the entire system for any complex loadings – taking account of the mutual influence of the raceway system and bolted connection.

Advantage Time saving due to faster prototype development, because there is no need for experimental component investigations thanks to the high level of compliance between the calculation results and results obtained empirically. Maximum accuracy and more targeted consulting.

Note The calculation results are of such a high quality that they can be presented as verification to the classification societies such as Lloyds Register, Det Norske Veritas, etc.

Calculation

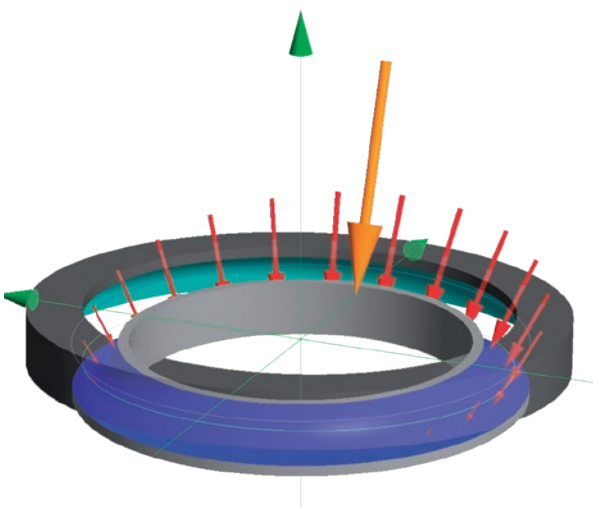

Figure 11: Load distribution in rothe erde® slewing bearings

Calculation of the friction moment

Calculation of the friction moment

The friction in the roller bearing influences heat development, it is decisive for the operating temperature. The following calculation of the friction moment M is based on theoretical and practical insights. The friction moment is influenced by the rolling friction coefficient, the anti-friction bodies, spacers, seals, load distribution and the load.

Other influencing parameters include:

- The plane-parallel deviation including angling of the upper and lower companion structure
- The grease fill and grease type
- The lubrication of the sealing lip and the seal prestressing
- The change in play in the bearing due to installation.

Note Of course, the calculated friction moment is subject to certain fluctuations that can be assumed at about $\pm 25\%$.

Non-loaded bearings that are not installed have an intrinsic friction moment that is not considered in the formula. This must be considered when using the formula.

In order to determine the necessary drive power, it is additionally necessary to consider the moments acting parallel to the axis of rotation of the bearing (acceleration moment, brake moment, moments from operating loads, etc.). The wind force that possibly acts as well as angled positions of the various components must also be taken into account.

1. Startup friction moment M_r

Ball bearings

$$M_r = \frac{\mu}{2} (4,4 \cdot M_k + F_a \cdot D_L + 3,81 \cdot F_r \cdot D_L) \quad [\text{kNm}]$$

Roller slewing bearings

$$M_r = \frac{\mu}{2} (4,1 \cdot M_k + F_a \cdot D_L + 2,05 \cdot F_r \cdot D_L) \quad [\text{kNm}]$$

2. Steady-state power $P_{\text{Beh.}}$

$$P_{\text{Beh.}} = M_r \cdot \omega \cdot \eta^{-1} \quad [\text{kNm} \cdot \text{s}^{-1}]$$

$$P_{\text{Beh.}} = \frac{M_r \cdot n}{9,55 \cdot \eta} \quad [\text{kW}]$$

Advantage As a special version, rothe erde® bearings are available with reduced rotational resistance. Such applications require consultation with us.

Expressions used in the formulas

F_a	= Axial load	[kN]
F_r	= Radial load	[kN]
M_k	= Resulting tilting moment	[kNm]
D_L	= Bearing raceway \emptyset	[m]
μ	= Friction coefficient	
ω	= Angular velocity	
$\omega = \frac{\pi \cdot n}{30}$		[s ⁻¹]
n	= Rotation speed of the slewing bearing	[rpm]
η	= Efficiency of the drive	

Various friction coefficients

$\mu = 0,008$	for series 25
$\mu = 0,008$	for series 23
$\mu = 0,006$	for series 28
$\mu = 0,006$	for series 06
$\mu = 0,006$	for series 09
$\mu = 0,003$	for series 19
$\mu = 0,004$	for series 01
$\mu = 0,004$	for series 16
$\mu = 0,003$	for series 12
$\mu = 0,003$	for series 14

Advantage We also provide high-precision bearings as well as zero-play and prestressed bearings. We can notify you of the friction moments on request.

Series 25, 23, 28 profile bearing

These Series are light Series from the thyssenkrupp rothe erde Germany GmbH range of slewing bearings.

The bearing cross sections have been kept relatively small in order to achieve greater economic efficiency. As a result, the slewing bearings must be mounted on a companion structure with high rigidity.

Contact surfaces

The contact surfaces for the slewing bearings must be level so the bearings will not be distorted when bolted on. Distortion could create narrowings in the raceways, leading to load peaks at these points. Mechanical machining of the contact surfaces is thus required. For the permitted deviations, see page 216 and table 8 page 225.

If machining is not possible under exceptional circumstances, unevenness can be compensated for by using a hardenable casting resin.

Accuracies

The bearings are produced in two accuracy versions:

- Normal bearing
- Precision bearing

For the individual bearing types, the bearing plays are listed in the dimension tables.

Installation, lubrication, maintenance

(See also pages 224–231)

The hardness gap (start and finish of the raceway hardening, marked with "S") or the filler plug of the profile ring should if possible be located in the neutral loading/ low loading zone of the point-loaded ring. This is also the location of the hole missing in the filler plug area with a double number of holes, in Series 23.

If central lubrication is provided, the existing grease nipples can be removed and replaced by the transitional pieces listed below.

Transition pieces provided

Thread-Ø A	Thread-Ø B
Grease nipple thread	M 10 x 1
M 8 x 1	M 12 x 1,5
	R r"
	R ¼"
	r"-27 NPTF (keg.)
	¼"-28 NF

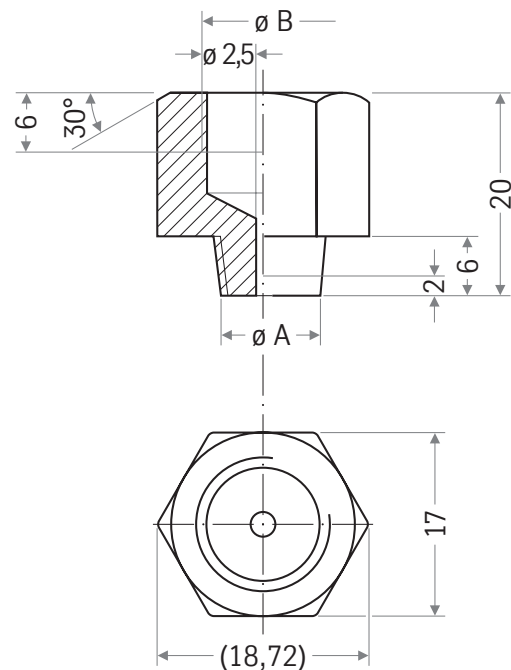

Materials

- Rings without gearing
 - Series 25 and Series 23
Profile steel C 45
 - Series 28
46 Cr 4 N
- Rings with gearing
 - Series 23
C 45 N
 - Series 28
46 Cr 4 N
- Roller bodies
made from anti-friction
bearing steel
- Ball raceways
 - Series 25
non-hardened or
surface hardened
 - Series 23
surface hardened
 - Series 28
surface hardened

Diagrams

The boundary load curves of the races only apply to axial loads applied from above. The limit load diagrams for Series 25 and Series 23 are used with the max. loadings that occur, including all additional loadings, test loads and shock factors (static and dynamic). In Series 28, the maximum load found must be multiplied by the “load factors” according to Table 1 on page 61.

The read-off load must be below the boundary load curve.

The bolt limit load curves apply to bolts in strength class 10.9 with normal and double number in profile rings. On geared rings, bolts of class 10.9 must be adequately dimensioned.

Bolt boundary load curves not shown are above the raceway boundary load curves.

Prerequisite for bolted connection of the bearing:

- Clamping length $5 \cdot d$ for full rings
- Clamping length $3 \cdot d$ for profile rings
- 5 joints
- Prestressing min. 70% of the yield strength

Note With a suspended axial load and further radial forces exceeding the drive force, it is necessary to have the raceway and bolts inspected by thyssenkrupp rothe erde Germany GmbH.

Series 25, 23, 28 profile bearing

Standard Series type 13, Normal bearing

Bearing without gearing		Geometry						Attachment						
Drawing number		$\emptyset D_L$ mm	$\emptyset D_a$ mm	$\emptyset D_i$ mm	H mm	$\emptyset O$ mm	$\emptyset U$ mm	$\emptyset L_a$ mm	n_a	$\emptyset B$ mm	$\emptyset L_i$ mm	n_i	$\emptyset B$ mm	
1	250.14.0300.013 Type 13/400	Unhardened race	323	401	233	40	348	298	380	8	14	260	8	14
2	250.14.0400.013 Type 13/500		421	501	333	40	446	396	480	8	14	360	8	14
3	250.15.0300.013 Type 13/400	Hardened race	323	401	233	40	348	298	380	8	14	260	8	14
4	250.15.0400.013 Type 13/500		421	501	333	40	446	396	480	8	14	360	8	14

If centering spigots are required for normal bearings, these must be specified when the order is placed. Centering spigots are only possible if * is indicated for the nominal diameter.

Dimensions of these centering spigots:

Type 13/400 ... 13/500

outside

- 0,5 mm

inside

+ 0,5 mm

For loads above the bolt boundary load curve with raceway boundary load curve 4 the number of fastening bolts must be doubled.

Static boundary load curves

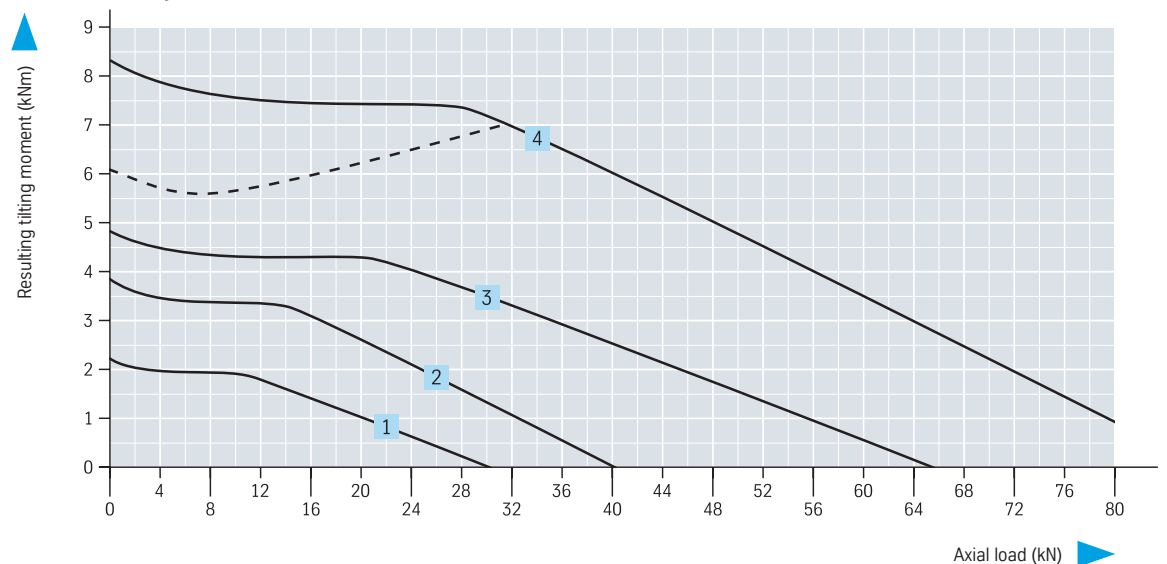

Miscellaneous			
kg	n_1	Y axial mm	Y radial mm
9,6	4	$\leq 0,5$	$\leq 0,5$
13,1	4	$\leq 0,5$	$\leq 0,5$
9,6	4	$\leq 0,5$	$\leq 0,5$
13,1	4	$\leq 0,5$	$\leq 0,5$

► n_1 = Tapered grease nipple
H 1a - 6 mm Ø
≈ evenly distributed

√ = $\sqrt{\text{rolled}}$

Diameter tolerances

Machined diameters with untoleranced drawing dimensions have the following tolerances:

- ≤ 315 mm ± 1,6 mm
- ≤ 1000 mm ± 2,5 mm

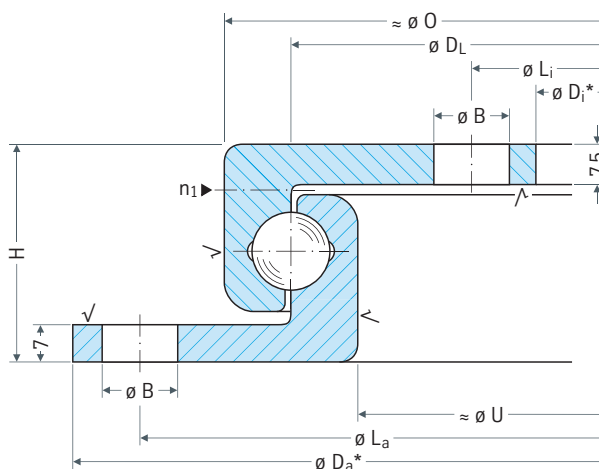

Bearing selection series 25, 23, 28

Series 25, 23, 28 profile bearing

Standard Series type 13, Normal bearing

Bearing without gearing		Geometry						Attachment					
Drawing number		$\emptyset D_L$ mm	$\emptyset D_a$ mm	$\emptyset D_i$ mm	H mm	$\emptyset O$ mm	$\emptyset U$ mm	$\emptyset L_a$ mm	n_a	$\emptyset B$ mm	$\emptyset L_i$ mm	n_i	$\emptyset B$ mm
3	250.15.0375.013 Type 13/400	323	400 - 0,09	234 + 0,07	40	348	298	380	8	14	260	8	14
4	250.15.0475.013 Type 13/500		500 - 0,10	334 + 0,09	40	446	396	480	8	14	360	8	14

If centering spigots are required for normal bearings, these must be specified when the order is placed. Centering spigots are only possible if * is indicated for the nominal diameter.

Dimensions of these centering spigots:

Type 13/400 ... 13/500	outside	inside
	- 0,5 mm	+ 0,5 mm

For loads above the bolt boundary load curve with raceway boundary load curve 4 the number of fastening bolts must be doubled.

Static boundary load curves

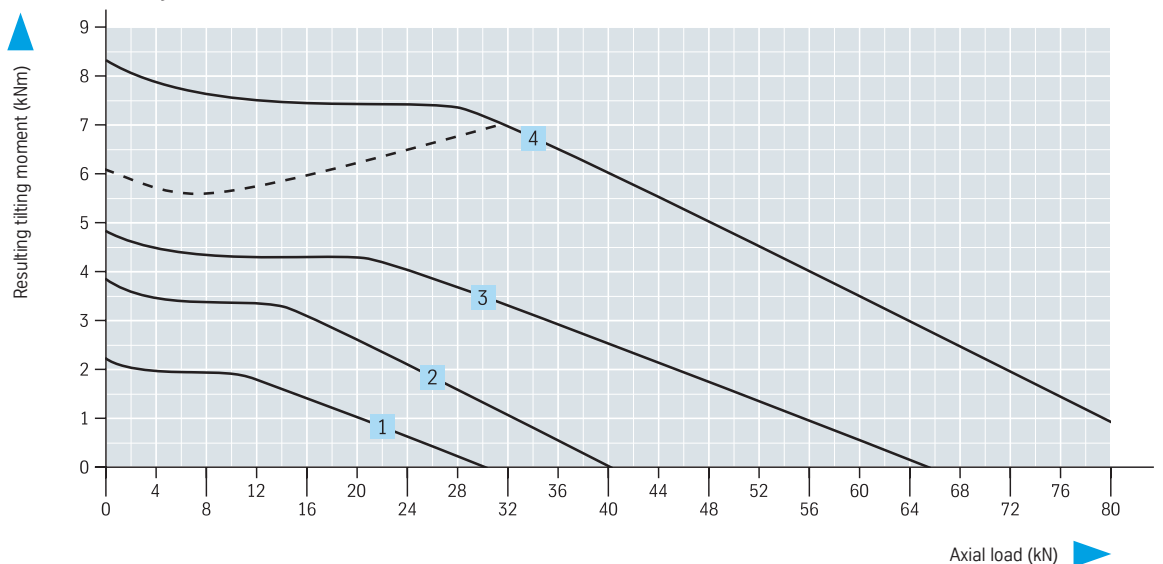

Miscellaneous		
kg	n_1	Y axial + radial mm
9,6	4	≤ 0 to 0,02
13,1	4	≤ 0 to 0,02

► n_1 = Tapered grease nipple
H 1a - 6 mm Ø
≈ evenly distributed

√ = $\sqrt{\text{rolled}}$

Diameter tolerances

Machined diameters with untoleranced drawing dimensions have the following tolerances:

- $\leq 315 \text{ mm} \pm 1,6 \text{ mm}$
- $\leq 1000 \text{ mm} \pm 2,5 \text{ mm}$

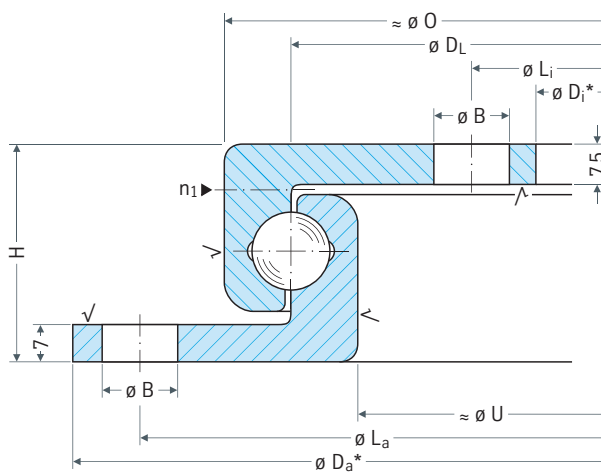

Bearing selection series 25, 23, 28

Series 25, 23, 28 profile bearing

Standard Series type 21, Normal bearing, normal number of holes profile ring

Double number of holes see curves 12 – 18, page 88

Bearing without gearing		Geometry									
Drawing number		$\varnothing D_L$ mm	$\varnothing D_a$ mm	$\varnothing D_i$ mm	H mm	$\varnothing O$ mm	$\varnothing U$ mm	$\varnothing A$ mm	$\varnothing C$ mm	H_u mm	H_o mm
5	230.20.0400.013 Type 21/520.0	414	518	304	56	412,5	415,5	453	375	10,5	10,5
6	230.20.0500.013 Type 21/650.0	544	648	434	56	542,5	545,5	583	505	10,5	10,5
7	230.20.0600.013 Type 21/750.0	644	748	534	56	642,5	645,5	683	605	10,5	10,5
8	230.20.0700.013 Type 21/850.0	744	848	634	56	742,5	745,5	783	705	10,5	10,5
9	230.20.0800.013 Type 21/950.0	844	948	734	56	842,5	845,5	883	805	10,5	10,5
10	230.20.0900.013 Type 21/1050.0	944	1048	834	56	942,5	945,5	983	905	10,5	10,5
11	230.20.1000.013 Type 21/1200.0	1094	1198	984	56	1092,5	1095,5	1133	1055	10,5	10,5

If centering spigots are required for normal bearings, these must be specified when the order is placed. Centering spigots are only possible if * is indicated for the nominal diameter.

Dimensions of these centering spigots:

	outside	inside
Type 21/520 ... 21/650	- 0,5 mm	+ 0,5 mm
Type 21/750 ... 21/950	- 0,6 mm	+ 0,6 mm
Type 21/1050 ... 21/1200	- 0,7 mm	+ 0,7 mm

For loads above the bolt boundary load curve with raceway boundary load curve 4 the number of fastening bolts must be doubled.

Static boundary load curves

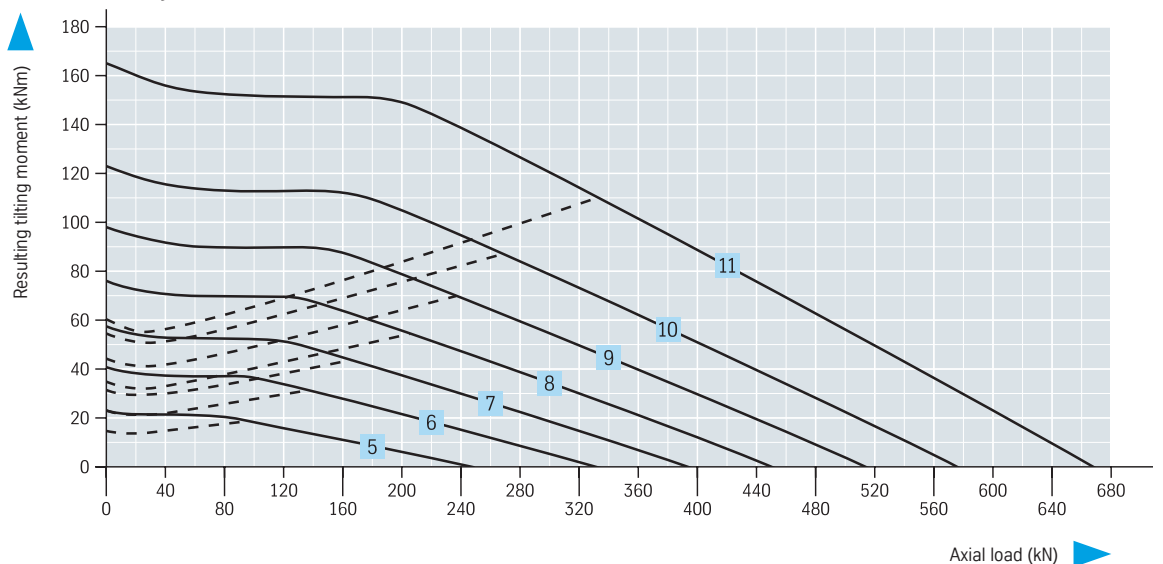

Attachment						Miscellaneous			
$\varnothing L_a$ mm	n_a	$\varnothing B$ mm	$\varnothing L_i$ mm	n_i	$\varnothing B$ mm	 kg	n_1	Y axial mm	Y radial mm
490	8	18	332	12	18	23,4	4	≤ 0,5	≤ 0,5
620	10	18	462	14	18	31,0	4	≤ 0,5	≤ 0,5
720	12	18	562	16	18	36,4	4	≤ 0,5	≤ 0,5
820	12	18	662	16	18	42,8	4	≤ 0,5	≤ 0,5
920	14	18	762	18	18	47,8	4	≤ 0,5	≤ 0,5
1020	16	18	862	20	18	53,1	4	≤ 0,5	≤ 0,5
1170	16	18	1012	20	18	61,9	4	≤ 0,5	≤ 0,5

► n_1 = Tapered grease nipple
 AM 8 x 1 DIN 71412
 ≈ evenly distributed
 On request, with non-geared bearings,
 the grease nipples can also be attached
 on the inner ring.

✓ = $\sqrt{\text{rolled}}$

Diameter tolerances

Machined diameters with untoleranced
 drawing dimensions have the following
 tolerances:

- ≤ 315 mm ± 1,6 mm
- ≤ 1000 mm ± 2,5 mm
- ≤ 2000 mm ± 3,5 mm

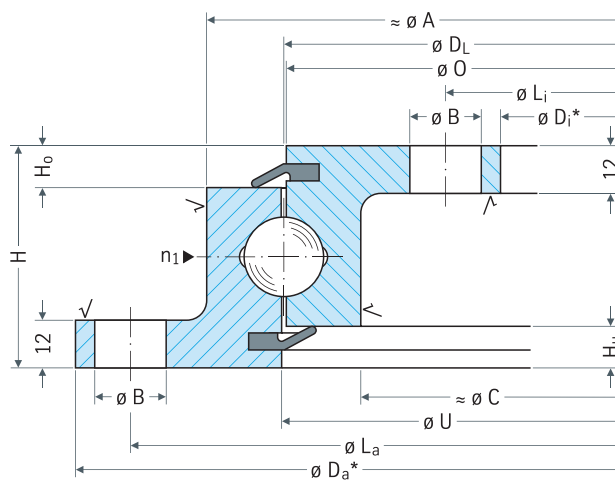

Bearing
 selection series
 25, 23, 28

Series 25, 23, 28 profile bearing

Standard Series type 21, Normal bearing, normal number of holes profile ring

Double number of holes see curves 12 – 18, page 90

Bearing with external gearing		Geometry							Attachment		
Drawing number		$\varnothing D_L$ mm	$\varnothing D_a$ mm	$\varnothing D_i$ mm	H mm	$\varnothing O$ mm	$\varnothing U$ mm	$\varnothing C$ mm	H_u mm	$\varnothing L_a$ mm	n_a
5	231.20.0400.013 Type 21/520.1	414	504	304	56	412,5	415,5	375	10,5	455	10
6	231.20.0500.013 Type 21/650.1	544	640,8	434	56	542,5	545,5	505	10,5	585	14
7	231.20.0600.013 Type 21/750.1	644	742,8	534	56	642,5	645,5	605	10,5	685	16
8	231.20.0700.013 Type 21/850.1	744	838,8	634	56	742,5	745,5	705	10,5	785	18
9	231.20.0800.013 Type 21/950.1	844	950,4	734	56	842,5	845,5	805	10,5	885	18
10	231.20.0900.013 Type 21/1050.1	944	1046,4	834	56	942,5	945,5	905	10,5	985	20
11	231.20.1000.013 Type 21/1200.1	1094	1198,4	984	56	1092,5	1095,5	1055	10,5	1135	22

$\varnothing D_a$ from 1991 tip relief 0,1 · m

If centering spigots are required for normal bearings, these must be specified when the order is placed. Centering spigots are only possible if * is indicated for the nominal diameter.

Dimensions of these centering spigots:

	outside	inside
Type 21/520 ... 21/650	- 0,5 mm	+ 0,5 mm
Type 21/750 ... 21/950	- 0,6 mm	+ 0,6 mm
Type 21/1050 ... 21/1200	- 0,7 mm	+ 0,7 mm

Centering height $H_z^* = 4,5$ mm
Centering height of the companion structure = $(H_z - 1)$ mm

For loads above the bolt boundary load curve with raceway boundary load curve 4 the number of fastening bolts must be doubled.

Static boundary load curves

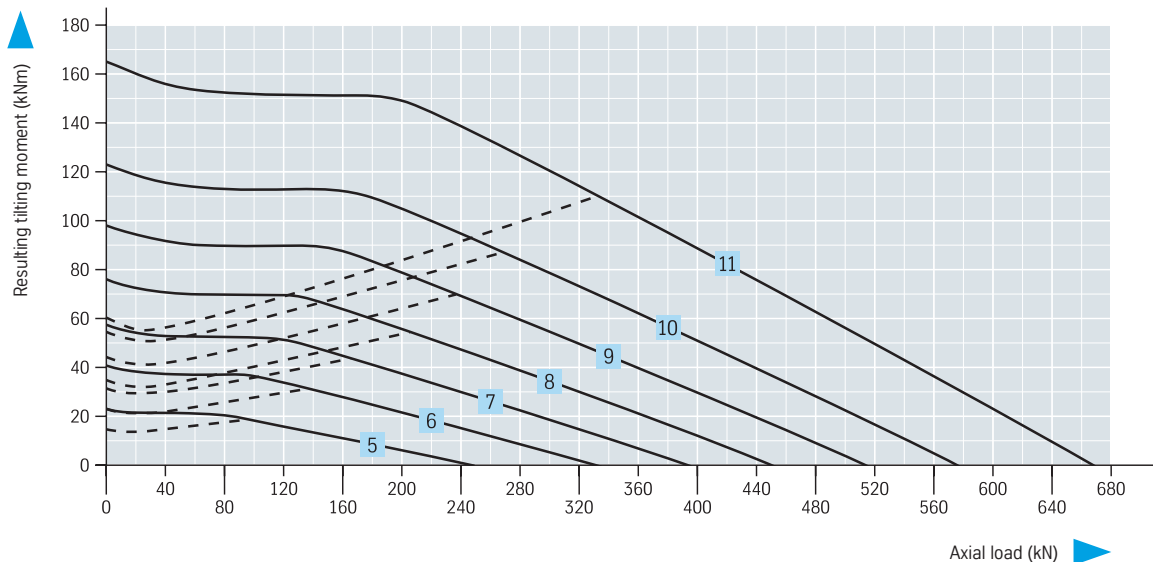

Attachment					Gearing							Miscellaneous			
M mm	t mm	∅ L _i mm	n ₁	∅ B mm	d mm	m mm	z	k · m mm	b mm	X1 kN	X2 kN	kg	n ₁	Y axial mm	Y radial mm
12	20	332	12	18	495	5	99	-0,5	45,5	11,75	23,50	29,3	4	≤ 0,5	≤ 0,5
12	20	462	14	18	630	6	105	-0,6	45,5	14,20	28,40	39,5	4	≤ 0,5	≤ 0,5
12	20	562	16	18	732	6	122	-0,6	45,5	14,20	28,40	47,6	4	≤ 0,5	≤ 0,5
12	20	662	16	18	828	6	138	-0,6	45,5	14,20	28,40	53,5	4	≤ 0,5	≤ 0,5
12	20	762	18	18	936	8	117	-0,8	45,5	18,93	37,86	65,1	4	≤ 0,5	≤ 0,5
12	20	862	20	18	1032	8	129	-0,8	45,5	18,93	37,86	69,6	4	≤ 0,5	≤ 0,5
12	20	1012	20	18	1184	8	148	-0,8	45,5	18,93	37,86	83,0	4	≤ 0,5	≤ 0,5

► n₁ = Tapered grease nipple
AM 8 x 1 DIN 71412
≈ evenly distributed

√ = ^{rolled}√

Diameter tolerances

Machined diameters with untoleranced drawing dimensions have the following tolerances:

- ≤ 315 mm ± 1,6 mm
- ≤ 1000 mm ± 2,5 mm
- ≤ 2000 mm ± 3,5 mm

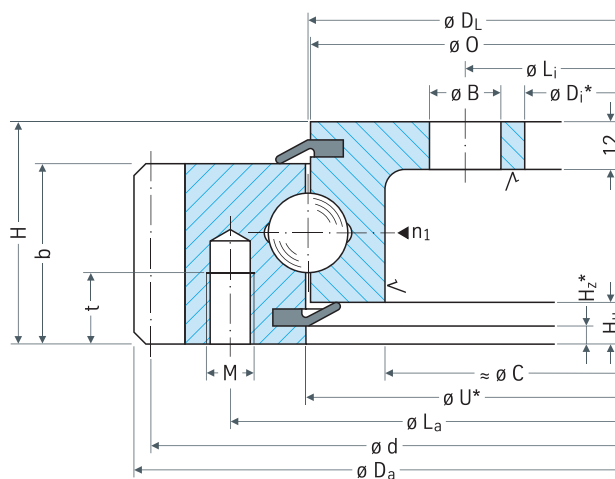

Bearing selection series 25, 23, 28

Series 25, 23, 28 profile bearing

Standard Series type 21, Normal bearing, normal number of holes profile ring

Double number of holes see curves 12 – 18, page 92

Bearing with internal gearing		Geometry							Attachment			
Drawing number		$\varnothing D_L$ mm	$\varnothing D_a$ mm	$\varnothing D_i$ mm	H mm	$\varnothing O$ mm	$\varnothing U$ mm	$\varnothing C$ mm	H_u mm	$\varnothing L_a$ mm	n_a	$\varnothing B$ mm
5	232.20.0400.013 Type 21/520.2	414	518	326,5	56	412,5	415,5	453	10,5	490	8	18
6	232.20.0500.013 Type 21/650.2	544	648	445,2	56	542,5	545,5	583	10,5	620	10	18
7	232.20.0600.013 Type 21/750.2	644	748	547,2	56	642,5	645,5	683	10,5	720	12	18
8	232.20.0700.013 Type 21/850.2	744	848	649,2	56	742,5	745,5	783	10,5	820	12	18
9	232.20.0800.013 Type 21/950.2	844	948	737,6	56	842,5	845,5	883	10,5	920	14	18
10	232.20.0900.013 Type 21/1050.2	944	1048	841,6	56	942,5	945,5	983	10,5	1020	16	18
11	232.20.1000.013 Type 21/1200.2	1094	1198	985,6	56	1092,5	1095,5	1133	10,5	1170	16	18

If centering spigots are required for normal bearings, these must be specified when the order is placed. Centering spigots are only possible if * is indicated for the nominal diameter.

Dimensions of these centering spigots:

	outside	inside
Type 21/520 ... 21/650	- 0,5 mm	+ 0,5 mm
Type 21/750 ... 21/950	- 0,6 mm	+ 0,6 mm
Type 21/1050 ... 21/1200	- 0,7 mm	+ 0,7 mm

Centering height $H_z^* = 4,5$ mm
Centering height of the companion structure = $(H_z - 1)$ mm

For loads above the bolt boundary load curve with raceway boundary load curve 4 the number of fastening bolts must be doubled.

Static boundary load curves

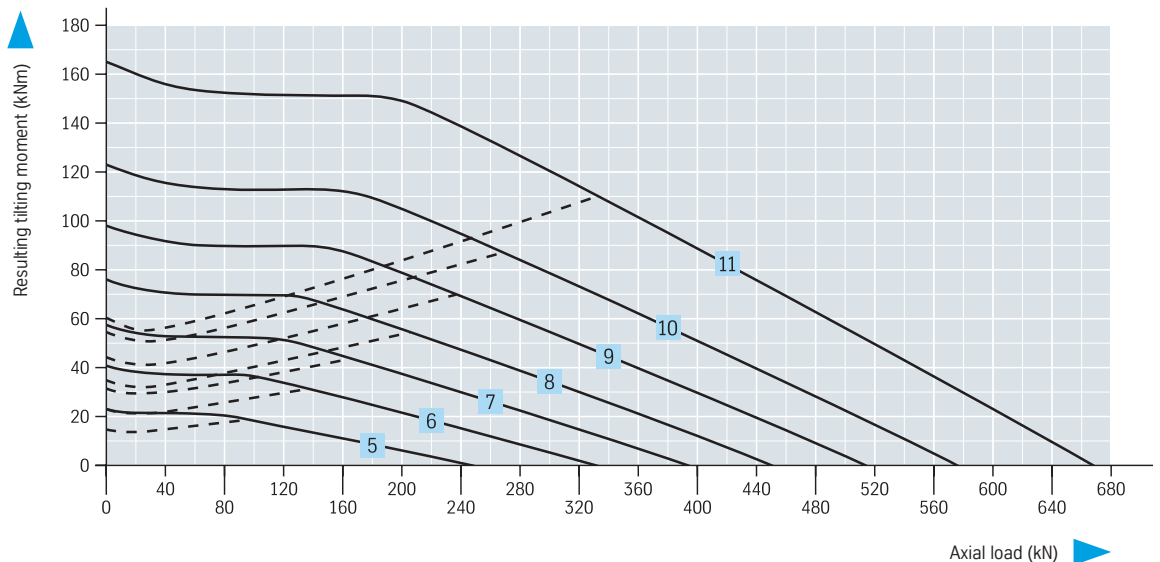

Attachment				Gearing						Miscellaneous				
$\emptyset L_1$ mm	n_1	M mm	t mm	d mm	m mm	z	k · m mm	b mm	X1 kN	X2 kN	 kg	n_1	Y axial mm	Y radial mm
375	12	12	20	335	5	67	-0,75	45,5	13,54	27,08	27,1	4	≤ 0,5	≤ 0,5
505	16	12	20	456	6	76	-0,60	45,5	16,00	32,00	36,9	4	≤ 0,5	≤ 0,5
605	18	12	20	558	6	93	-0,60	45,5	15,62	31,24	43,7	4	≤ 0,5	≤ 0,5
705	20	12	20	660	6	110	-0,60	45,5	15,32	30,64	51,1	4	≤ 0,5	≤ 0,5
805	20	12	20	752	8	94	-0,80	45,5	20,80	41,60	61,6	4	≤ 0,5	≤ 0,5
905	22	12	20	856	8	107	-0,80	45,5	20,49	40,98	65,8	4	≤ 0,5	≤ 0,5
1055	24	12	20	1000	8	125	-0,80	45,5	20,16	40,32	80,7	4	≤ 0,5	≤ 0,5

► n_1 = Tapered grease nipple
AM 8 x 1 DIN 71412
≈ evenly distributed

√ = ^{rolled}√

Diameter tolerances

Machined diameters with untoleranced drawing dimensions have the following tolerances:

- ≤ 1000 mm ± 2,5 mm
- ≤ 2000 mm ± 3,5 mm

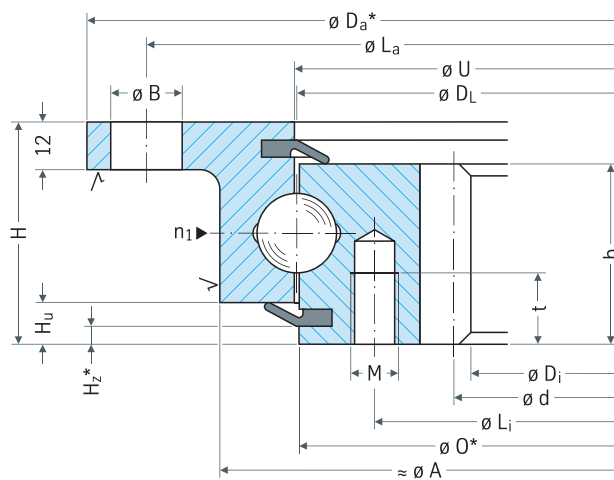

Bearing selection series 25, 23, 28

Series 25, 23, 28 profile bearing

Standard Series type 21, Normal bearing, double number of holes profile ring

One hole is missing in the area of the filler plug

Bearing without gearing		Geometry									
Drawing number		$\varnothing D_L$ mm	$\varnothing D_a$ mm	$\varnothing D_i$ mm	H mm	$\varnothing O$ mm	$\varnothing U$ mm	$\varnothing A$ mm	$\varnothing C$ mm	H_u mm	H_o mm
12	230.20.0400.503 Type 21/520.0	414	518	304	56	412,5	415,5	453	375	10,5	10,5
13	230.20.0500.503 Type 21/650.0	544	648	434	56	542,5	545,5	583	505	10,5	10,5
14	230.20.0600.503 Type 21/750.0	644	748	534	56	642,5	645,5	683	605	10,5	10,5
15	230.20.0700.503 Type 21/850.0	744	848	634	56	742,5	745,5	783	705	10,5	10,5
16	230.20.0800.503 Type 21/950.0	844	948	734	56	842,5	845,5	883	805	10,5	10,5
17	230.20.0900.503 Type 21/1050.0	944	1048	834	56	942,5	945,5	983	905	10,5	10,5
18	230.20.1000.503 Type 21/1200.0	1094	1198	984	56	1092,5	1095,5	1133	1055	10,5	10,5

If centering spigots are required for normal bearings, these must be specified when the order is placed.

Centering spigots are only possible if * is indicated for the nominal diameter.

Dimensions of these centering spigots:

	outside	inside
Type 21/520 ... 21/650	- 0,5 mm	+ 0,5 mm
Type 21/750 ... 21/950	- 0,6 mm	+ 0,6 mm
Type 21/1050 ... 21/1200	- 0,7 mm	+ 0,7 mm

Static boundary load curves

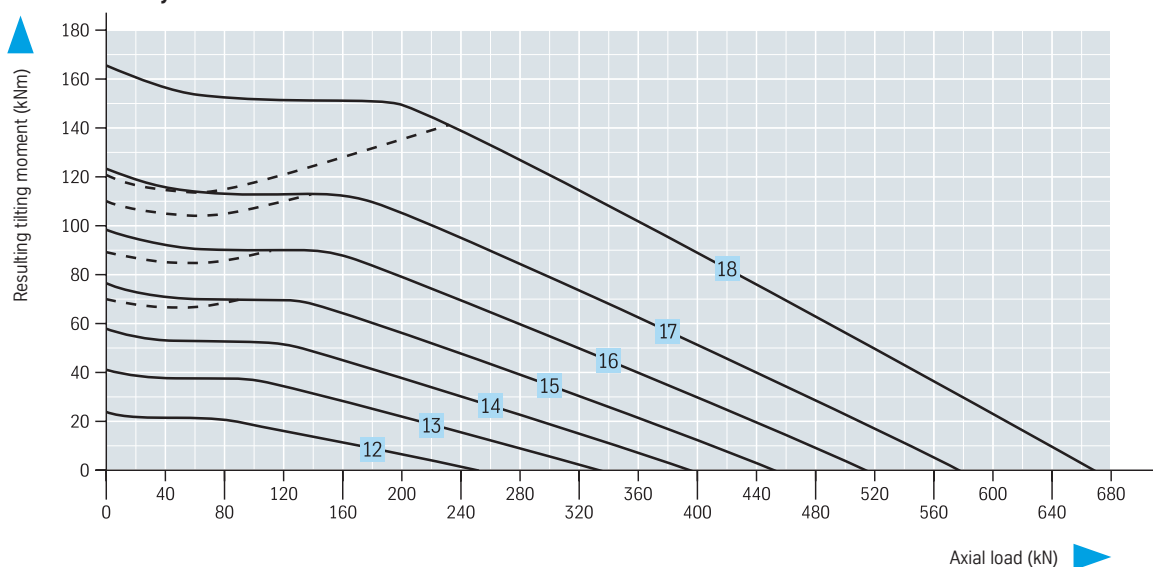

Attachment						Miscellaneous			
$\varnothing L_a$ mm	n_a	$\varnothing B$ mm	$\varnothing L_i$ mm	n_i	$\varnothing B$ mm	 kg	n_1	Y axial mm	Y radial mm
490	16	18	332	24	18	23,0	4	≤ 0,5	≤ 0,5
620	20	18	462	28	18	30,4	4	≤ 0,5	≤ 0,5
720	24	18	562	32	18	35,8	4	≤ 0,5	≤ 0,5
820	24	18	662	32	18	42,2	4	≤ 0,5	≤ 0,5
920	28	18	762	36	18	47,1	4	≤ 0,5	≤ 0,5
1020	32	18	862	40	18	52,3	4	≤ 0,5	≤ 0,5
1170	32	18	1012	40	18	61,1	4	≤ 0,5	≤ 0,5

► n_1 = Tapered grease nipple
AM 8 x 1 DIN 71412
≈ evenly distributed

On request, with non-geared bearings, the grease nipples can also be attached on the inner ring.

√ = $\sqrt{\text{rolled}}$

Diameter tolerances

Machined diameters with untoleranced drawing dimensions have the following tolerances:

- ≤ 315 mm ± 1,6 mm
- ≤ 1000 mm ± 2,5 mm
- ≤ 2000 mm ± 3,5 mm

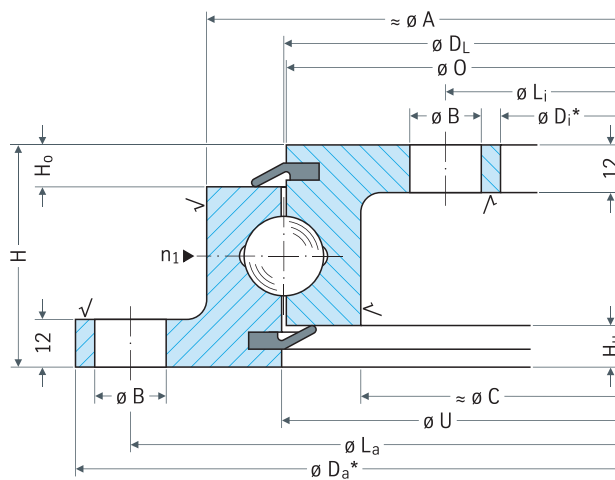

Bearing selection series 25, 23, 28

Series 25, 23, 28 profile bearing

Standard Series type 21, Normal bearing, double number of holes profile ring

One hole is missing in the area of the filler plug

Bearing with external gearing		Geometry							Attachment			
Drawing number		$\varnothing D_L$ mm	$\varnothing D_a$ mm	$\varnothing D_i$ mm	H mm	$\varnothing O$ mm	$\varnothing U$ mm	$\varnothing C$ mm	H_u mm	$\varnothing L_a$ mm	n_a	M mm
12	231.20.0400.503 Type 21/520.1	414	504	304	56	412,5	415,5	375	10,5	455	10	12
13	231.20.0500.503 Type 21/650.1	544	640,8	434	56	542,5	545,5	505	10,5	585	14	12
14	231.20.0600.503 Type 21/750.1	644	742,8	534	56	642,5	645,5	605	10,5	685	16	12
15	231.20.0700.503 Type 21/850.1	744	838,8	634	56	742,5	745,5	705	10,5	785	18	12
16	231.20.0800.503 Type 21/950.1	844	950,4	734	56	842,5	845,5	805	10,5	885	18	12
17	231.20.0900.503 Type 21/1050.1	944	1046,4	834	56	942,5	945,5	905	10,5	985	20	12
18	231.20.1000.503 Type 21/1200.1	1094	1198,4	984	56	1092,5	1095,5	1055	10,5	1135	22	12

$\varnothing D_a$ from 1991 tip relief 0,1 · m

If centering spigots are required for normal bearings, these must be specified when the order is placed. Centering spigots are only possible if * is indicated for the nominal diameter.

Dimensions of these centering spigots:	outside	inside
Type 21/520 ... 21/650	- 0,5 mm	+ 0,5 mm
Type 21/750 ... 21/950	- 0,6 mm	+ 0,6 mm
Type 21/1050 ... 21/1200	- 0,7 mm	+ 0,7 mm

Centering height $H_z^* = 4,5$ mm
Centering height of the companion structure = $(H_z - 1)$ mm

Static boundary load curves

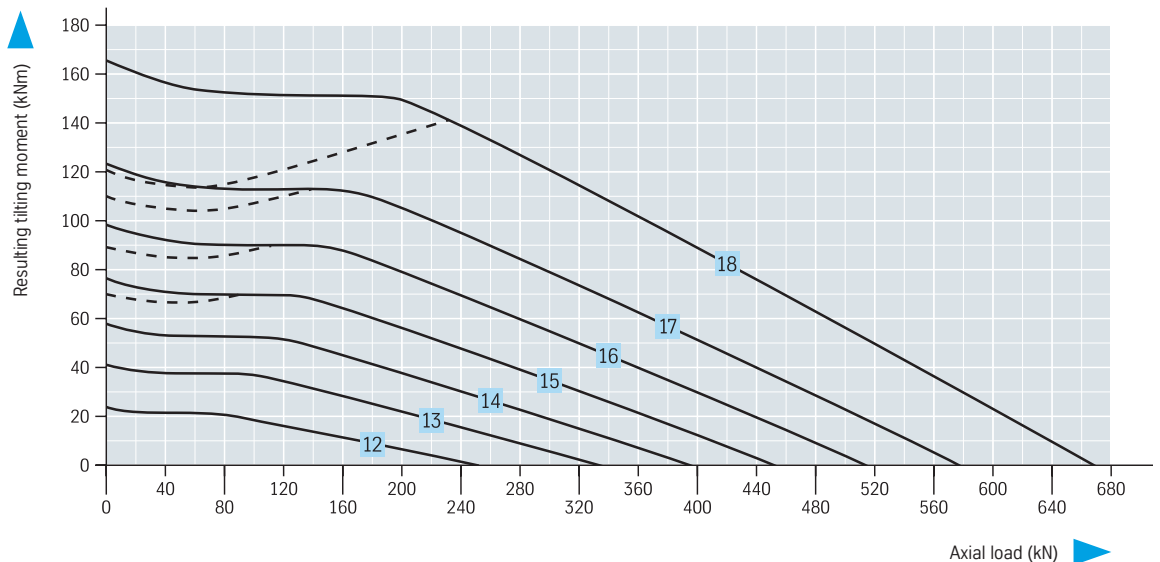

Attachment				Gearing						Miscellaneous				
t mm	∅ L _i mm	n ₁	∅ B mm	d mm	m mm	z	k · m mm	b mm	X1 kN	X2 kN	 kg	n ₁	Y axial mm	Y radial mm
20	332	24	18	495	5	99	-0,5	45,5	11,75	23,50	29,0	4	≤ 0,5	≤ 0,5
20	462	28	18	630	6	105	-0,5	45,5	14,20	28,40	39,2	4	≤ 0,5	≤ 0,5
20	562	32	18	732	6	122	-0,6	45,5	14,20	28,40	47,2	4	≤ 0,5	≤ 0,5
20	662	32	18	828	6	138	-0,6	45,5	14,20	28,40	53,1	4	≤ 0,5	≤ 0,5
20	762	36	18	936	8	117	-0,8	45,5	18,93	37,86	64,7	4	≤ 0,5	≤ 0,5
20	862	40	18	1032	8	129	-0,8	45,5	18,93	37,86	69,1	4	≤ 0,5	≤ 0,5
20	1012	40	18	1184	8	148	-0,8	45,5	18,93	37,86	82,5	4	≤ 0,5	≤ 0,5

► n₁ = Tapered grease nipple
AM 8 x 1 DIN 71412
≈ evenly distributed

√ = ^{rolled}√

Diameter tolerances

Machined diameters with untoleranced drawing dimensions have the following tolerances:

- ≤ 315 mm ± 1,6 mm
- ≤ 1000 mm ± 2,5 mm
- ≤ 2000 mm ± 3,5 mm

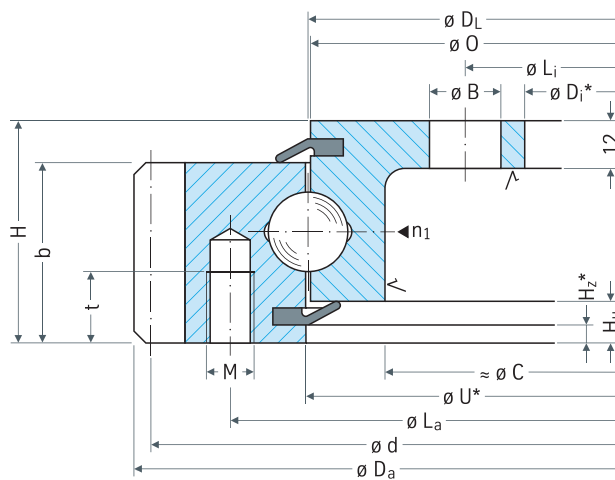

Bearing selection series 25, 23, 28

Series 25, 23, 28 profile bearing

Standard Series type 21, Normal bearing, double number of holes profile ring

One hole is missing in the area of the filler plug

Bearing with internal gearing		Geometry							Attachment			
Drawing number		$\varnothing D_L$ mm	$\varnothing D_a$ mm	$\varnothing D_i$ mm	H mm	$\varnothing O$ mm	$\varnothing U$ mm	$\varnothing A$ mm	H_u mm	$\varnothing L_a$ mm	n_a	$\varnothing B$ mm
12	232.20.0400.503 Type 21/520.2	414	518	326,5	56	412,5	415,5	453	10,5	490	16	18
13	232.20.0500.503 Type 21/650.2	544	648	445,2	56	542,5	545,5	583	10,5	620	20	18
14	232.20.0600.503 Type 21/750.2	644	748	547,2	56	642,5	645,5	683	10,5	720	24	18
15	232.20.0700.503 Type 21/850.2	744	848	649,2	56	742,5	745,5	783	10,5	820	24	18
16	232.20.0800.503 Type 21/950.2	844	948	737,6	56	842,5	845,5	883	10,5	920	28	18
17	232.20.0900.503 Type 21/1050.2	944	1048	841,6	56	942,5	945,5	983	10,5	1020	32	18
18	232.20.1000.503 Type 21/1200.2	1094	1198	985,6	56	1092,5	1095,5	1133	10,5	1170	32	18

If centering spigots are required for normal bearings, these must be specified when the order is placed. Centering spigots are only possible if * is indicated for the nominal diameter.

Dimensions of these centering spigots:

	outside	inside
Type 21/520 ... 21/650	- 0,5 mm	+ 0,5 mm
Type 21/750 ... 21/950	- 0,6 mm	+ 0,6 mm
Type 21/1050 ... 21/1200	- 0,7 mm	+ 0,7 mm

Centering height $H_z^* = 4,5$ mm

Centering height of the companion structure = $(H_z - 1)$ mm

Static boundary load curves

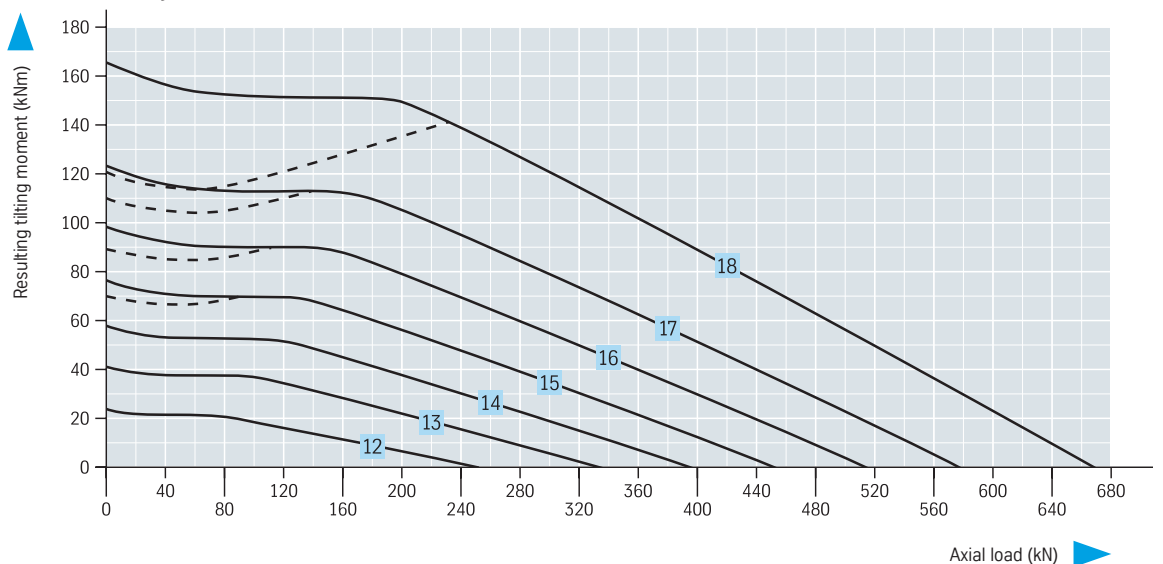

Series 25, 23, 28 profile bearing

Standard Series type 21, Bearing with restricted play

Bearing without gearing		Geometry									
Drawing number		$\varnothing D_L$ mm	$\varnothing D_a$ mm	$\varnothing D_i$ mm	H mm	$\varnothing O$ mm	$\varnothing U$ mm	$\varnothing A$ mm	$\varnothing C$ mm	H_u mm	H_o mm
5	230.21.0475.013 Type 21/520.0	414	517 -0,11	305 +0,08	56	412,5	415,5	453	375	10,5	10,5
6	230.21.0575.013 Type 21/650.0	544	647 -0,13	435 +0,10	56	542,5	545,5	583	505	10,5	10,5
7	230.21.0675.013 Type 21/750.0	644	747 -0,13	535 +0,11	56	642,5	645,5	683	605	10,5	10,5
8	230.21.0775.013 Type 21/850.0	744	847 -0,14	635 +0,13	56	742,5	745,5	783	705	10,5	10,5
9	230.21.0875.013 Type 21/950.0	844	947 -0,14	735 +0,13	56	842,5	845,5	883	805	10,5	10,5
10	230.21.0975.013 Type 21/1050.0	944	1047 -0,17	835 +0,14	56	942,5	945,5	983	905	10,5	10,5
11	230.21.1075.013 Type 21/1200.0	1094	1197 -0,17	985 +0,14	56	1092,5	1095,5	1133	1055	10,5	10,5

For loads above the bolt boundary load curve with raceway boundary load curve 4 the number of fastening bolts must be doubled.

Static boundary load curves

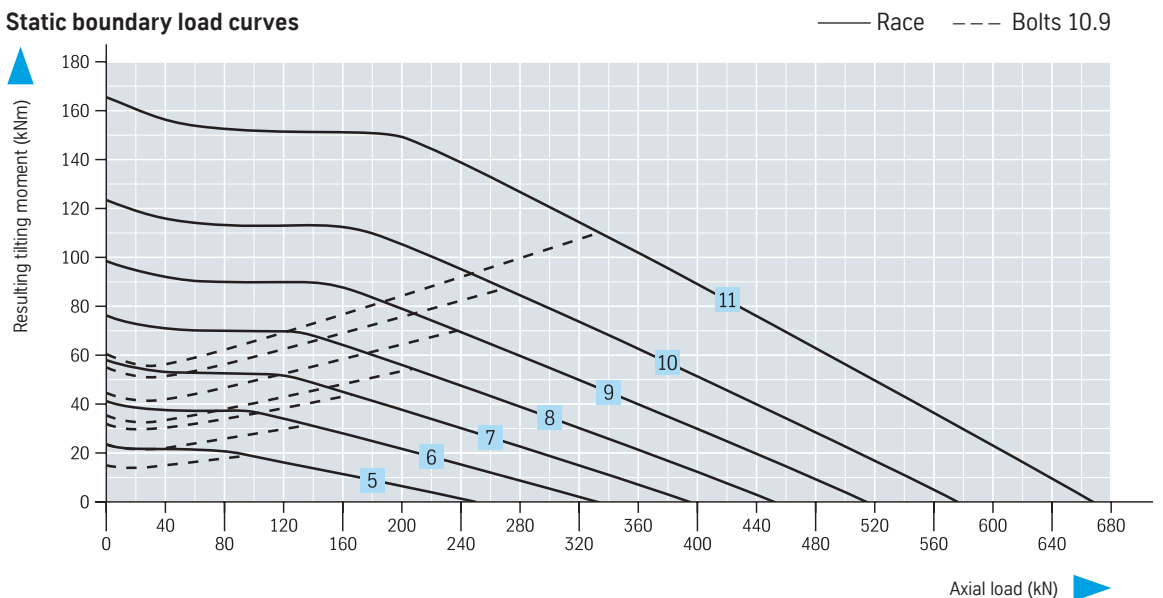

Attachment						Miscellaneous		
$\varnothing L_a$ mm	n_a	$\varnothing B$ mm	$\varnothing L_i$ mm	n_i	$\varnothing B$ mm	 kg	n_1	Y axial + radial mm
490	8	18	332	12	18	23,4	4	≥ 0 to 0,03
620	10	18	462	14	18	31,0	4	≥ 0 to 0,03
720	12	18	562	16	18	36,4	4	≥ 0 to 0,04
820	12	18	662	16	18	42,8	4	≥ 0 to 0,04
920	14	18	762	18	18	47,8	4	≥ 0 to 0,05
1020	16	18	862	20	18	53,1	4	≥ 0 to 0,05
1170	16	18	1012	20	18	61,9	4	≥ 0 to 0,06

► n_1 = Tapered grease nipple
AM 8 x 1 DIN 71412
 \approx evenly distributed

On request, with non-gear bearings, the grease nipples can also be attached on the inner ring.

✓ = $\sqrt{\text{rolled}}$

Diameter tolerances

Machined diameters with untoleranced drawing dimensions have the following tolerances:

- ≤ 315 mm ± 1,6 mm
- ≤ 1000 mm ± 2,5 mm
- ≤ 2000 mm ± 3,5 mm

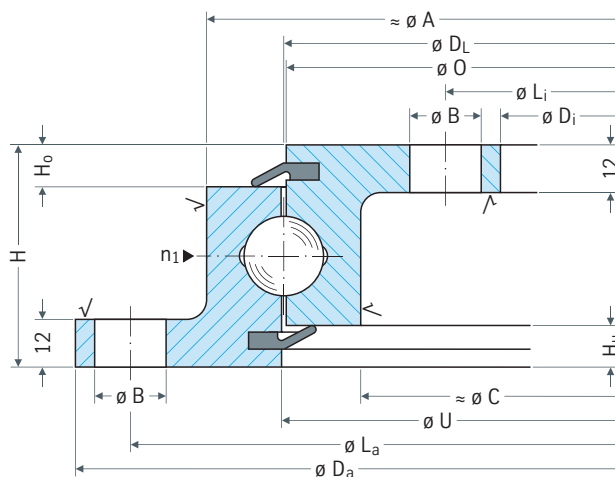

Bearing selection series 25, 23, 28

Series 25, 23, 28 profile bearing

Standard Series type 21, Bearing with restricted play

Bearing with external gearing		Geometry							Attachment			
Drawing number		$\varnothing D_L$ mm	$\varnothing D_a$ mm	$\varnothing D_i$ mm	H mm	$\varnothing O$ mm	$\varnothing U$ mm	$\varnothing C$ mm	H_u mm	$\varnothing L_a$ mm	n_a	M mm
5	231.21.0475.013 Type 21/520.1	414	504	305 +0,08	56	412,5	417 +0,10	375	10,5	455	10	12
6	231.21.0575.013 Type 21/650.1	544	640,8	435 +0,10	56	542,5	547 +0,11	505	10,5	585	14	12
7	231.21.0675.013 Type 21/750.1	644	742,8	535 +0,11	56	642,5	647 +0,13	605	10,5	685	16	12
8	231.21.0775.013 Type 21/850.1	744	838,8	635 +0,13	56	742,5	747 +0,13	705	10,5	785	18	12
9	231.21.0875.013 Type 21/950.1	844	950,4	735 +0,13	56	842,5	847 +0,14	805	10,5	885	18	12
10	231.21.0975.013 Type 21/1050.1	944	1046,4	835 +0,14	56	942,5	947 +0,14	905	10,5	985	20	12
11	231.21.1075.013 Type 21/1200.1	1094	1198,4	985 +0,14	56	1092,5	1097 +0,17	1055	10,5	1135	22	12

$\varnothing D_a$ from 1991 tip relief 0,1 · m

Centering height $H_z^* = 4,5$ mm

Centering height of the companion structure = $(H_z - 1)$ mm

For loads above the bolt boundary load curve with raceway boundary load curve 4 the number of fastening bolts must be doubled.

Static boundary load curves

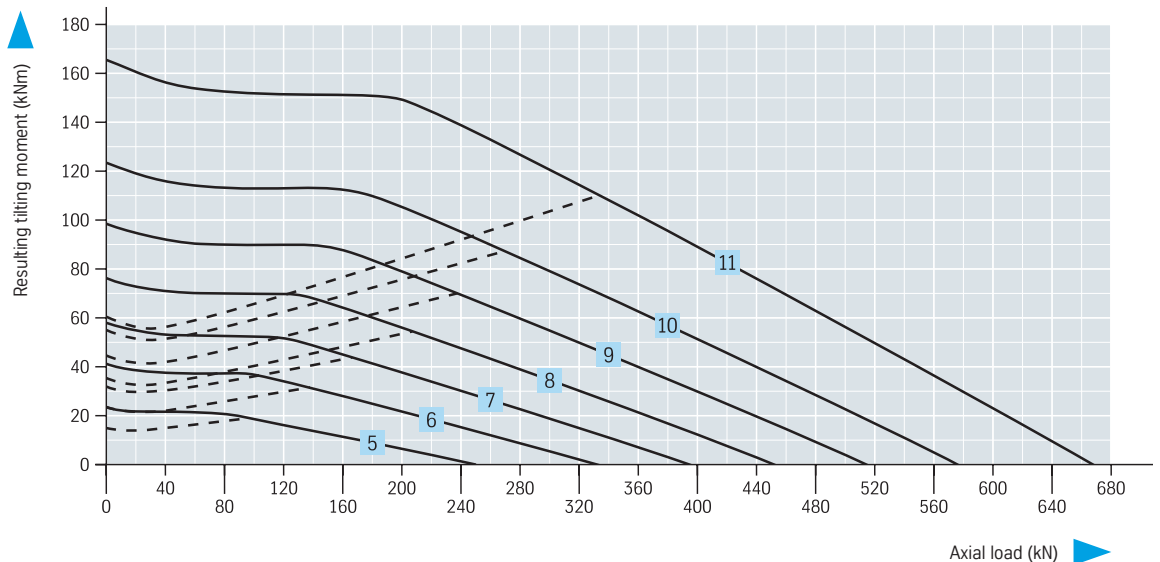

Attachment				Gearing						Miscellaneous			
t mm	∅ L _i mm	n ₁	∅ B mm	d mm	m mm	z	k · m mm	b mm	X1 kN	X2 kN	 kg	n ₁	Y axial + radial mm
20	332	12	18	495	5	99	-0,5	45,5	11,75	23,50	29,3	4	≥ 0 to 0,03
20	462	14	18	630	6	105	-0,6	45,5	14,20	28,40	39,5	4	≥ 0 to 0,03
20	562	16	18	732	6	122	-0,6	45,5	14,20	28,40	47,6	4	≥ 0 to 0,04
20	662	16	18	828	6	138	-0,6	45,5	14,20	28,40	53,5	4	≥ 0 to 0,04
20	762	18	18	936	8	117	-0,8	45,5	18,93	37,86	65,1	4	≥ 0 to 0,05
20	862	20	18	1032	8	129	-0,8	45,5	18,93	37,86	69,6	4	≥ 0 to 0,05
20	1012	20	18	1184	8	148	-0,8	45,5	18,93	37,86	83,0	4	≥ 0 to 0,06

► n₁ = Tapered grease nipple
AM 8 x 1 DIN 71412
≈ evenly distributed

√ = √^{rolled}

Diameter tolerances

Machined diameters with untoleranced drawing dimensions have the following tolerances:

- ≤ 315 mm ± 1,6 mm
- ≤ 1000 mm ± 2,5 mm
- ≤ 2000 mm ± 3,5 mm

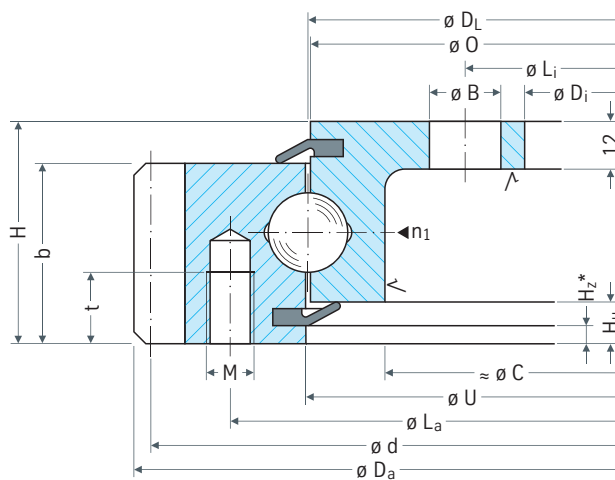

Bearing selection series 25, 23, 28

Series 25, 23, 28 profile bearing

Standard Series type 21, Bearing with restricted play

Bearing with internal gearing		Geometry							Attachment			
Drawing number		$\varnothing D_L$ mm	$\varnothing D_a$ mm	$\varnothing D_i$ mm	H mm	$\varnothing O$ mm	$\varnothing U$ mm	$\varnothing A$ mm	H_u mm	$\varnothing L_a$ mm	n_a	$\varnothing B$ mm
5	232.21.0475.013 Type 21/520.2	414	517 -0,11	326,5	56	411 -0,10	415,5	453	10,5	490	8	18
6	232.21.0575.013 Type 21/650.2	544	647 -0,13	445,2	56	541 -0,11	545,5	583	10,5	620	10	18
7	232.21.0675.013 Type 21/750.2	644	747 -0,13	547,2	56	641 -0,13	645,5	683	10,5	720	12	18
8	232.21.0775.013 Type 21/850.2	744	847 -0,14	649,2	56	741 -0,13	745,5	783	10,5	820	12	18
9	232.21.0875.013 Type 21/950.2	844	947 -0,14	737,6	56	841 -0,14	845,5	883	10,5	920	14	18
10	232.21.0975.013 Type 21/1050.2	944	1047 -0,17	841,6	56	941 -0,14	945,5	983	10,5	1020	16	18
11	232.21.1075.013 Type 21/1200.2	1094	1197 -0,17	985,6	56	1091 -0,17	1095,5	1133	10,5	1170	16	18

Centering height $H_z^* = 4,5$ mm
 Centering height of the companion structure = $(H_z - 1)$ mm

For loads above the bolt boundary load curve with raceway boundary load curve 4 the number of fastening bolts must be doubled.

Static boundary load curves

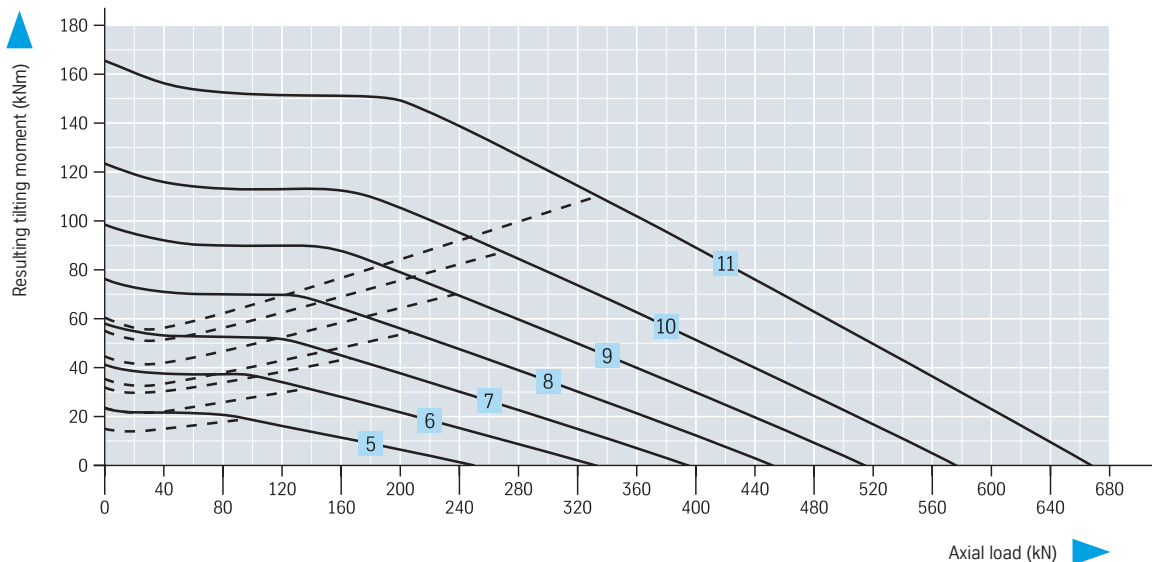

Attachment				Gearing								Miscellaneous		
$\varnothing L_1$ mm	n_1	M mm	t mm	d mm	m mm	z	k · m mm	b mm	X1 kN	X2 kN	kg	n_1	Y axial + radial mm	
375	12	12	20	335	5	67	-0,75	45,5	13,54	27,08	27,1	4	≥ 0 to 0,03	
505	16	12	20	456	6	76	-0,60	45,5	16,00	32,00	36,9	4	≥ 0 to 0,03	
605	18	12	20	558	6	93	-0,60	45,5	15,62	31,24	43,7	4	≥ 0 to 0,04	
705	20	12	20	660	6	110	-0,60	45,5	15,32	30,64	51,1	4	≥ 0 to 0,04	
805	20	12	20	752	8	94	-0,80	45,5	20,80	41,60	61,6	4	≥ 0 to 0,05	
905	22	12	20	856	8	107	-0,80	45,5	20,49	40,98	65,8	4	≥ 0 to 0,05	
1055	24	12	20	1000	8	125	-0,80	45,5	20,16	40,32	80,7	4	≥ 0 to 0,06	

► n_1 = Tapered grease nipple
AM 8 x 1 DIN 71412
≈ evenly distributed

✓ = $\sqrt{\text{rolled}}$

Diameter tolerances

Machined diameters with untoleranced drawing dimensions have the following tolerances:

- ≤ 1000 mm ± 2,5 mm
- ≤ 2000 mm ± 3,5 mm

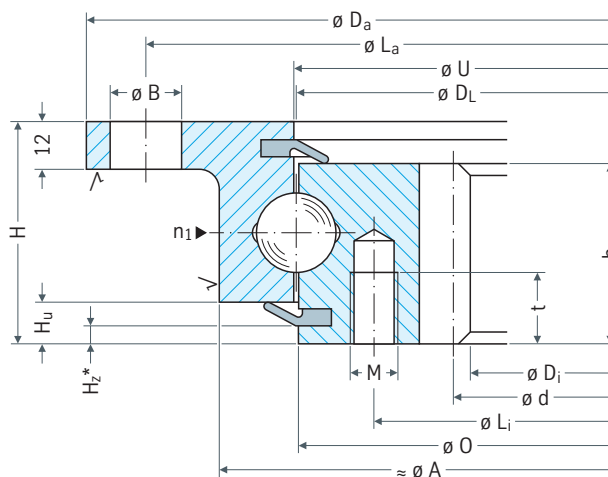

Bearing selection series 25, 23, 28

Series 25, 23, 28 profile bearing

Standard Series type 110, Normal bearing

Bearing without gearing		Geometry									
Drawing number		$\varnothing D_L$ mm	$\varnothing D_a$ mm	$\varnothing D_i$ mm	H mm	$\varnothing O$ mm	$\varnothing U$ mm	$\varnothing A$ mm	$\varnothing C$ mm	H_u mm	H_o mm
19	280.30.0900.013 Type 110/1100.0	955	1100	805	90	956,5	953,5	1017	893	19	19
20	280.30.1000.013 Type 110/1200.0	1055	1200	905	90	1056,5	1053,5	1117	993	19	19
21	280.30.1100.013 Type 110/1300.0	1155	1300	1005	90	1156,5	1153,5	1217	1093	19	19
22	280.30.1200.013 Type 110/1400.0	1255	1400	1105	90	1256,5	1253,5	1317	1193	19	19
23	280.30.1300.013 Type 110/1500.0	1355	1500	1205	90	1356,5	1353,5	1417	1293	19	19
24	280.30.1400.013 Type 110/1600.0	1455	1600	1305	90	1456,5	1453,5	1517	1393	19	19

If centering spigots are required for normal bearings, these must be specified when the order is placed. Centering spigots are only possible if * is indicated for the nominal diameter.

Dimensions of these

centering spigots:

Type 110/1100 ... 110/1300 - 0,25 mm

Type 110/1400 ... 110/1600 - 0,30 mm

outside

inside

+ 0,25 mm

+ 0,30 mm

Raceway read-off loads for static boundary load curves and utilization period curves must be found with load factors acc. to Table 1, page 61.

Static boundary load curves

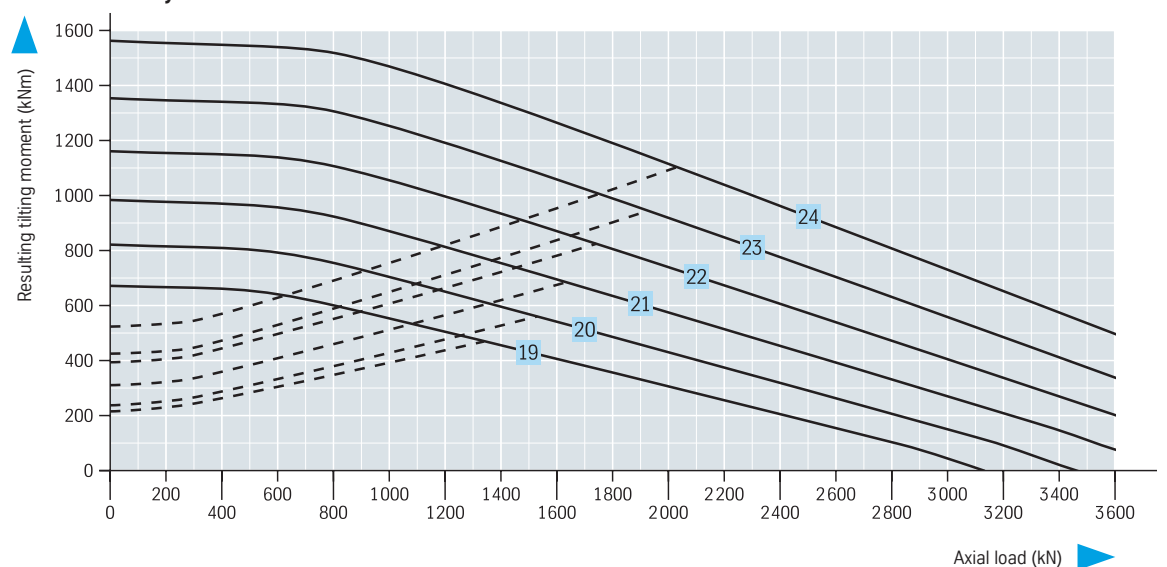

Attachment						Miscellaneous			
$\varnothing L_a$ mm	n_a	$\varnothing B$ mm	$\varnothing L_i$ mm	n_i	$\varnothing B$ mm	 kg	n_1	Y axial mm	Y radial mm
1060	30	22	845	30	22	131	6	≤ 0,40	≤ 0,31
1160	30	22	945	30	22	145	6	≤ 0,40	≤ 0,31
1260	36	22	1045	36	22	159	6	≤ 0,40	≤ 0,31
1360	42	22	1145	42	22	172	6	≤ 0,45	≤ 0,37
1460	42	22	1245	42	22	186	6	≤ 0,45	≤ 0,37
1560	48	22	1345	48	22	200	6	≤ 0,45	≤ 0,37

► n_1 = Tapered grease nipple
AM 8 x 1 DIN 71412
≈ evenly distributed

On request, with non-gear bearings, the grease nipples can also be attached on the inner ring.

Diameter tolerances

Machined diameters with untoleranced drawing dimensions have the following tolerances:

- ≤ 1000 mm ± 2,5 mm
- ≤ 2000 mm ± 3,5 mm

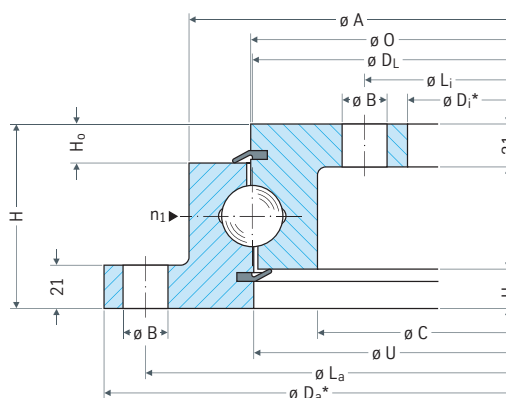

Bearing selection series 25, 23, 28

Utilization period curves – 30 000 revolutions

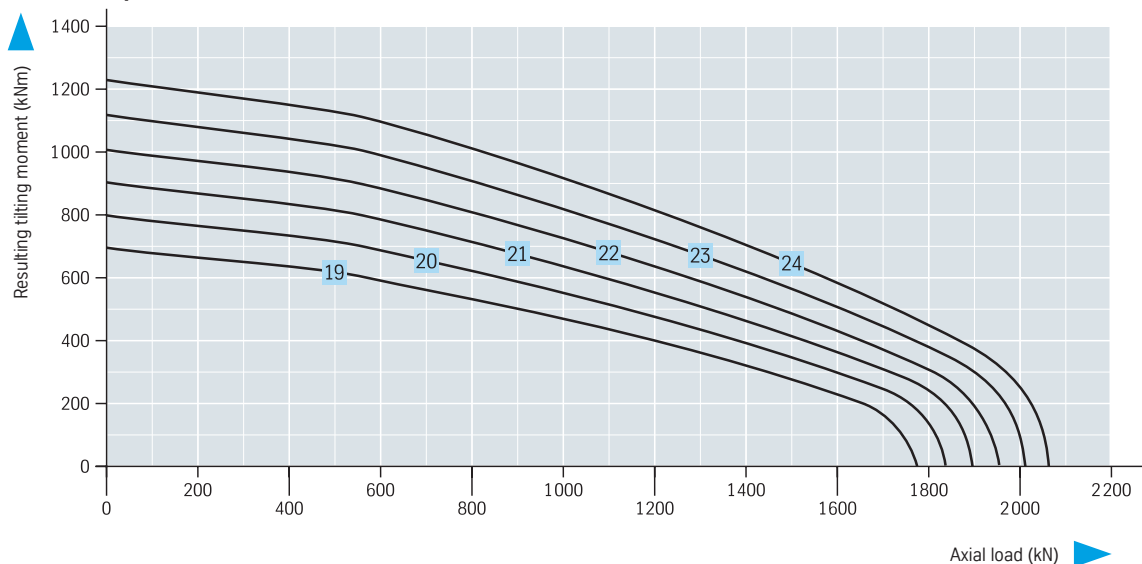

Series 25, 23, 28 profile bearing

Standard Series type 110, Normal bearing

Bearing with external gearing		Geometry							Attachment			
Drawing number		$\varnothing D_L$ mm	$\varnothing D_a$ mm	$\varnothing D_i$ mm	H mm	$\varnothing O$ mm	$\varnothing U$ mm	$\varnothing C$ mm	H_u mm	$\varnothing L_a$ mm	n_a	M mm
19	281.30.0900.013 Type 110/1100.1	955	1096,2	805	90	956,5	953,5	893	19	1016	30	20
20	281.30.1000.013 Type 110/1200.1	1055	1198	905	90	1056,5	1053,5	993	19	1116	30	20
21	281.30.1100.013 Type 110/1300.1	1155	1298	1005	90	1156,5	1153,5	1093	19	1216	36	20
22	281.30.1200.013 Type 110/1400.1	1255	1398	1105	90	1256,5	1253,5	1193	19	1316	42	20
23	281.30.1300.013 Type 110/1500.1	1355	1498	1205	90	1356,5	1353,5	1293	19	1416	42	20
24	281.30.1400.013 Type 110/1600.1	1455	1598	1305	90	1456,5	1453,5	1393	19	1516	48	20

$\varnothing D_a$ from 1991 tip relief 0,1 · m

If centering spigots are required for normal bearings, these must be specified when the order is placed. Centering spigots are only possible if * is indicated for the nominal diameter.

Dimensions of these

centering spigots:	outside	inside
Type 110/1100 ... 110/1300	- 0,25 mm	+ 0,25 mm
Type 110/1400 ... 110/1600	- 0,30 mm	+ 0,30 mm

Centering height $H_z = 13$ mm
Centering height of the companion structure = $(H_z - 1)$ mm

Raceway read-off loads for static boundary load curves and utilization period curves must be found with load factors acc. to Table 1, page 61.

Static boundary load curves

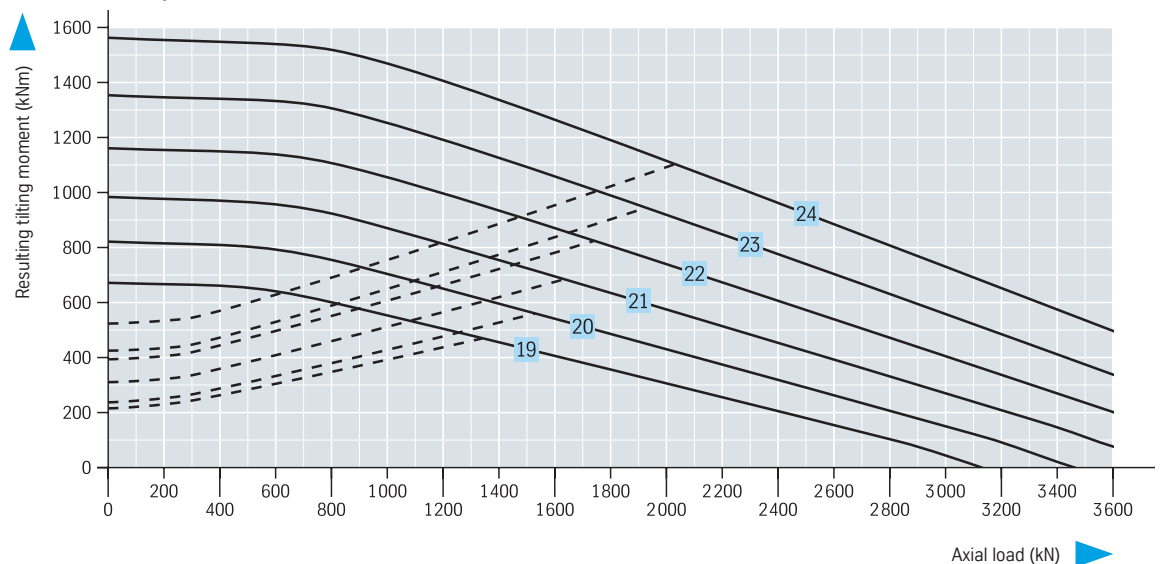

Attachment				Gearing						Miscellaneous				
t mm	∅ L _a mm	n _a	∅ B mm	d mm	m mm	z	k · m mm	b mm	X1 kN	X2 kN	 kg	n ₁	Y axial mm	Y radial mm
40	845	30	22	1080	9	120	- 0,9	71	32,76	65,52	165	6	≤ 0,40	≤ 0,31
40	945	30	22	1180	10	118	- 1,0	71	36,40	72,80	183	6	≤ 0,40	≤ 0,31
40	1045	36	22	1280	10	128	- 1,0	71	36,40	72,80	200	6	≤ 0,40	≤ 0,31
40	1145	42	22	1380	10	138	- 1,0	71	36,40	72,80	216	6	≤ 0,45	≤ 0,37
40	1245	42	22	1480	10	148	- 1,0	71	36,40	72,80	234	6	≤ 0,45	≤ 0,37
40	1345	48	22	1580	10	158	- 1,0	71	36,40	72,80	250	6	≤ 0,45	≤ 0,37

► n₁ = Tapered grease nipple
AM 8 x 1 DIN 71412
≈ evenly distributed

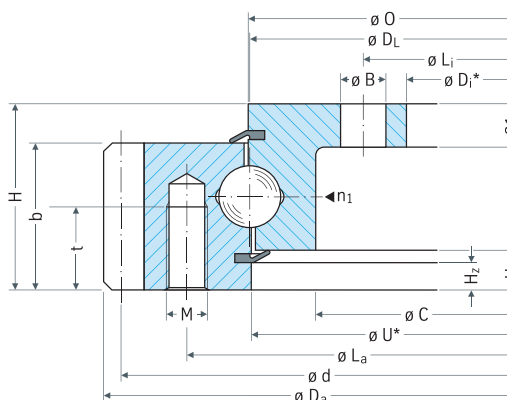

Bearing selection series 25, 23, 28

Diameter tolerances

Machined diameters with untoleranced drawing dimensions have the following tolerances:

- ≤ 1000 mm ± 2,5 mm
- ≤ 2000 mm ± 3,5 mm

Utilization period curves – 30 000 revolutions

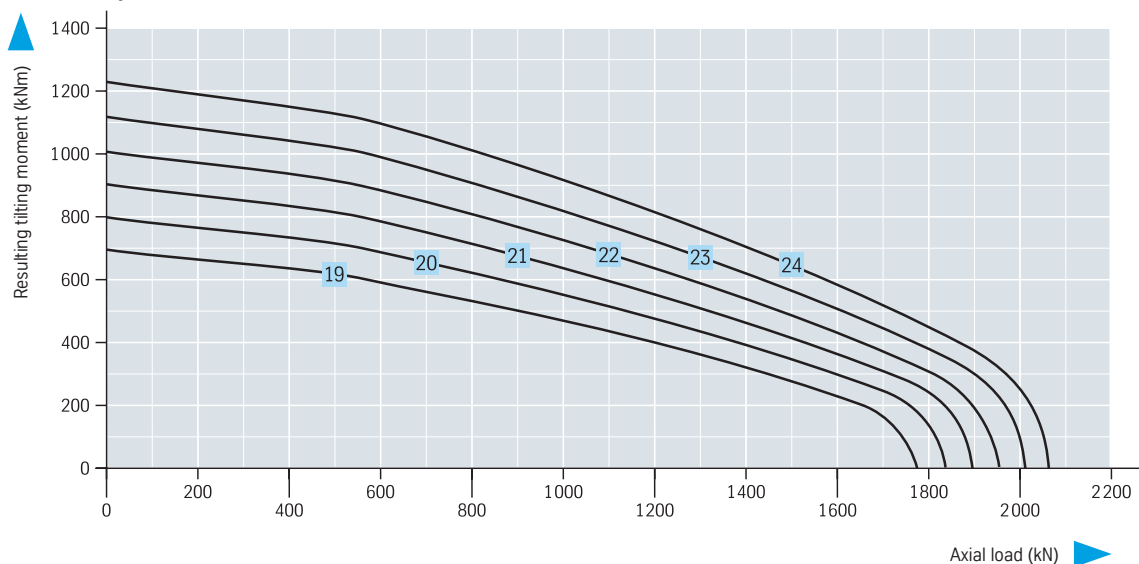

Series 25, 23, 28 profile bearing

Standard Series type 110, Normal bearing

Bearing with internal gearing		Geometry							Attachment			
Drawing number		$\varnothing D_L$ mm	$\varnothing D_a$ mm	$\varnothing D_i$ mm	H mm	$\varnothing O$ mm	$\varnothing U$ mm	$\varnothing A$ mm	H_u mm	$\varnothing L_a$ mm	n_a	$\varnothing B$ mm
19	282.30.0900.013 Type 110/1100.2	955	1100	812	90	956,5	953,5	1017	19	1060	30	22
20	282.30.1000.013 Type 110/1200.2	1055	1200	912	90	1056,5	1053,5	1117	19	1160	30	22
21	282.30.1100.013 Type 110/1300.2	1155	1300	1012	90	1156,5	1153,5	1217	19	1260	36	22
22	282.30.1200.013 Type 110/1400.2	1255	1400	1112	90	1256,5	1253,5	1317	19	1360	42	22
23	282.30.1300.013 Type 110/1500.2	1355	1500	1212	90	1356,5	1353,5	1417	19	1460	42	22
24	282.30.1400.013 Type 110/1600.2	1455	1600	1310	90	1456,5	1453,5	1517	19	1560	48	22

If centering spigots are required for normal bearings, these must be specified when the order is placed. Centering spigots are only possible if * is indicated for the nominal diameter.

Dimensions of these

centering spigots:	outside	inside
Type 110/1100 ... 110/1300	- 0,25 mm	+ 0,25 mm
Type 110/1400 ... 110/1600	- 0,30 mm	+ 0,30 mm

Centering height $H_z = 13$ mm
Centering height of the companion structure = $(H_z - 1)$ mm

Raceway read-off loads for static boundary load curves and utilization period curves must be found with load factors acc. to Table 1, page 61.

Static boundary load curves

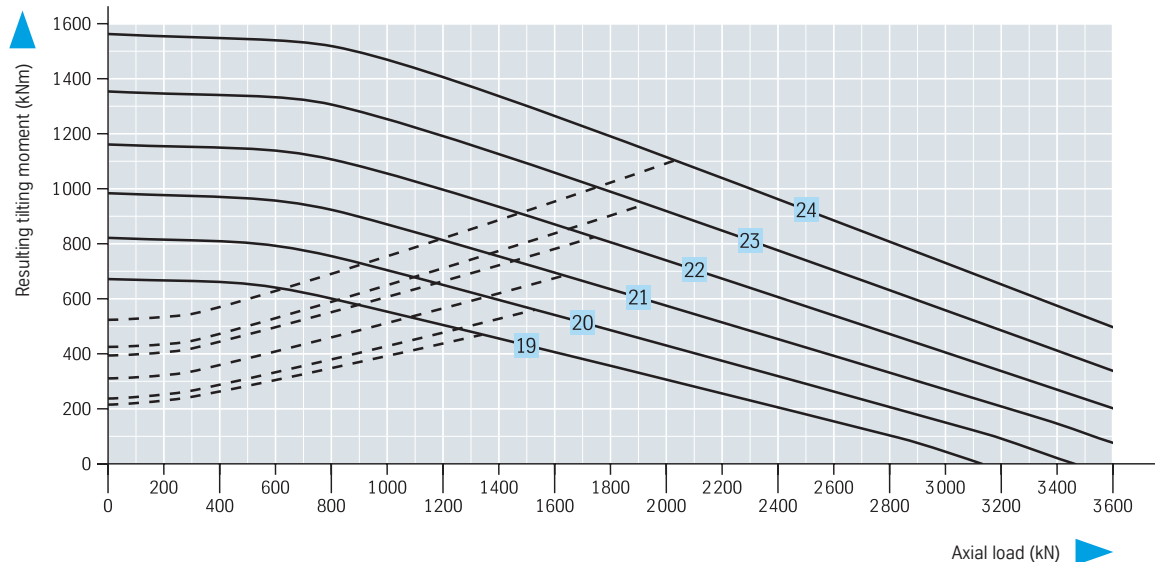

Attachment				Gearing						Miscellaneous				
$\emptyset L_1$ mm	n_1	M mm	t mm	d mm	m mm	z	k · m mm	b mm	X1 kN	X2 kN	 kg	n_1	Y axial mm	Y radial mm
894	30	20	40	830	10	83	- 1,0	71	40,60	81,20	159	6	≤ 0,40	≤ 0,31
994	30	20	40	930	10	93	- 1,0	71	40,06	80,12	176	6	≤ 0,40	≤ 0,31
1094	36	20	40	1030	10	103	- 1,0	71	39,58	79,16	192	6	≤ 0,40	≤ 0,31
1194	42	20	40	1130	10	113	- 1,0	71	39,18	78,36	208	6	≤ 0,45	≤ 0,37
1294	42	20	40	1230	10	123	- 1,0	71	38,83	77,66	226	6	≤ 0,45	≤ 0,37
1394	48	20	40	1330	10	133	—	71	38,55	77,10	243	6	≤ 0,45	≤ 0,37

► n_1 = Tapered grease nipple
AM 8 x 1 DIN 71412
≈ evenly distributed

Diameter tolerances

Machined diameters with untoleranced drawing dimensions have the following tolerances:

- ≤ 1000 mm ± 2,5 mm
- ≤ 2000 mm ± 3,5 mm

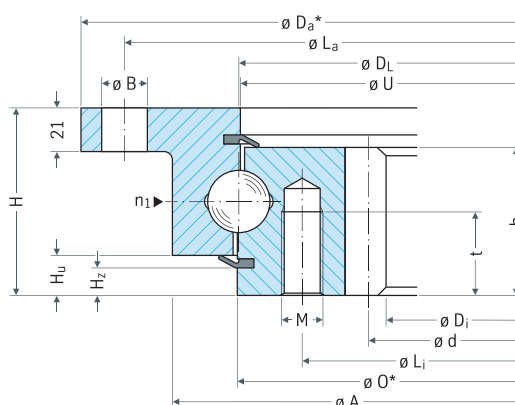

Bearing selection series 25, 23, 28

Utilization period curves – 30 000 revolutions

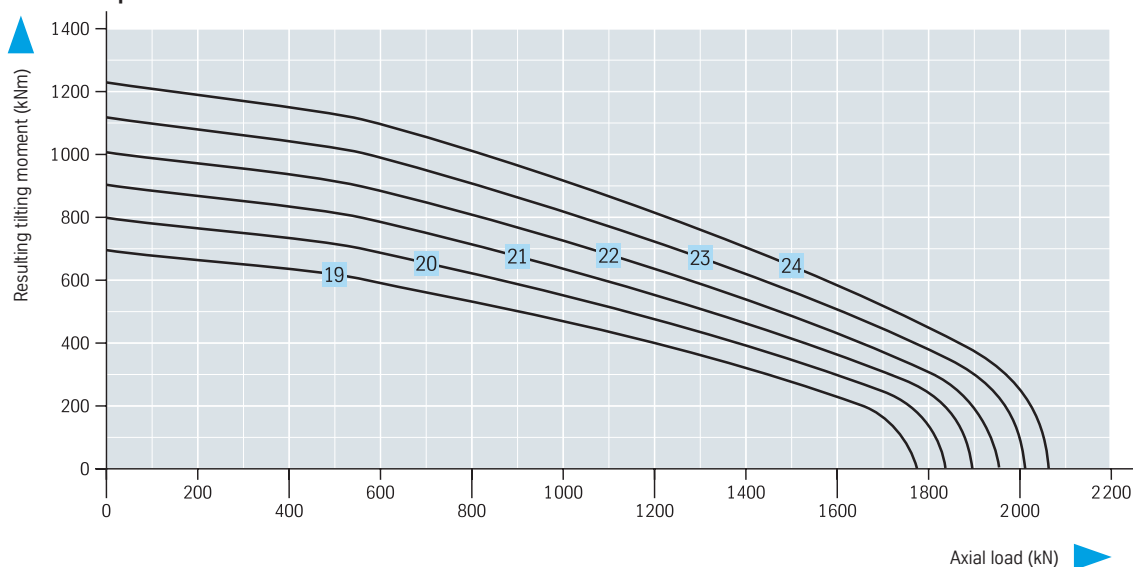

Series 25, 23, 28 profile bearing

Standard Series type 110, Bearing with restricted play

Bearing without gearing		Geometry									
Drawing number		$\varnothing D_L$ mm	$\varnothing D_a$ mm	$\varnothing D_i$ mm	H mm	$\varnothing O$ mm	$\varnothing U$ mm	$\varnothing A$ mm	$\varnothing C$ mm	H_u mm	H_o mm
19	280.30.0975.013 Type 110/1100.0	955	1098 -0,17	807 +0,14	90	956,5	953,5	1017	893	19	19
20	280.30.1075.013 Type 110/1200.0	1055	1198 -0,17	907 +0,14	90	1056,5	1053,5	1117	993	19	19
21	280.30.1175.013 Type 110/1300.0	1155	1298 -0,20	1007 +0,17	90	1156,5	1153,5	1217	1093	19	19
22	280.30.1275.013 Type 110/1400.0	1255	1398 -0,20	1107 +0,17	90	1256,5	1253,5	1317	1193	19	19
23	280.30.1375.013 Type 110/1500.0	1355	1498 -0,20	1207 +0,17	90	1356,5	1353,5	1417	1293	19	19
24	280.30.1475.013 Type 110/1600.0	1455	1598 -0,20	1307 +0,20	90	1456,5	1453,5	1517	1393	19	19

Raceway read-off loads for static boundary load curves and utilization period curves must be found with load factors acc. to Table 1, page 61.

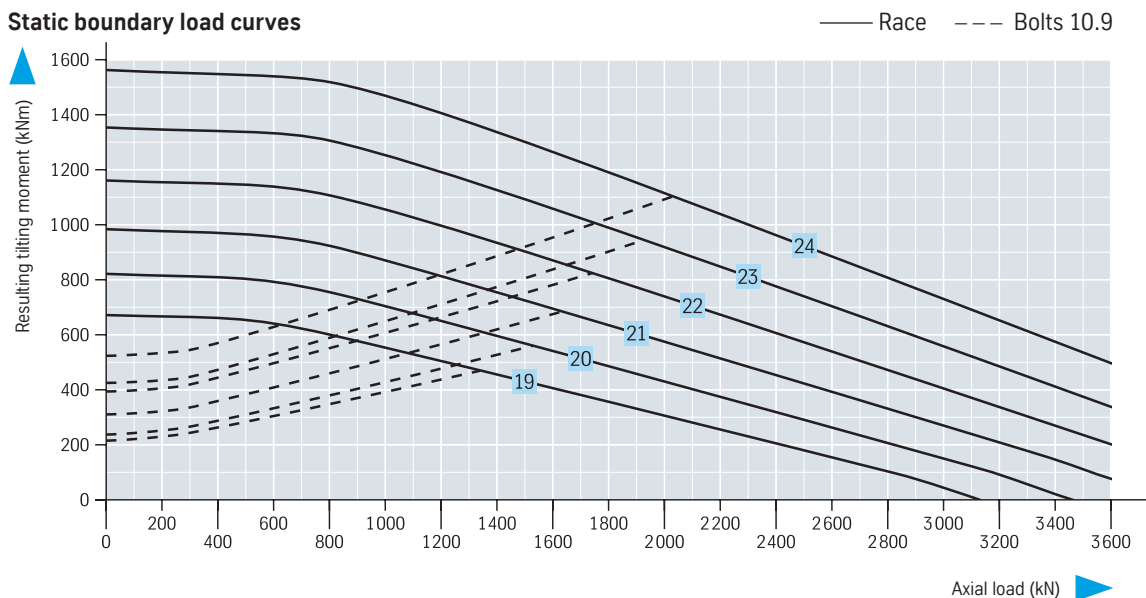

Attachment						Miscellaneous		
$\varnothing L_a$ mm	n_a	$\varnothing B$ mm	$\varnothing L_i$ mm	n_i	$\varnothing B$ mm	kg	n_i	Y axial + radial mm
1060	30	22	845	30	22	131	6	≥ 0 to 0,06
1160	30	22	945	30	22	145	6	≥ 0 to 0,06
1260	36	22	1045	36	22	159	6	≥ 0 to 0,06
1360	42	22	1145	42	22	172	6	≥ 0 to 0,07
1460	42	22	1245	42	22	186	6	≥ 0 to 0,07
1560	48	22	1345	48	22	200	6	≥ 0 to 0,07

► n_1 = Tapered grease nipple
AM 8 x 1 DIN 71412
≈ evenly distributed

On request, with non-gear bearings, the grease nipples can also be attached on the inner ring.

Diameter tolerances

Machined diameters with untoleranced drawing dimensions have the following tolerances:

- ≤ 1000 mm ± 2,5 mm
- ≤ 2000 mm ± 3,5 mm

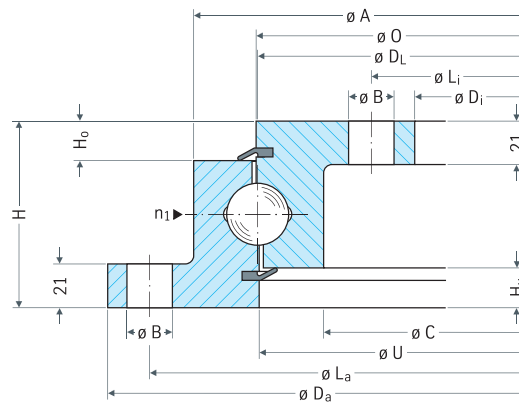

Bearing selection series 25, 23, 28

Utilization period curves – 30 000 revolutions

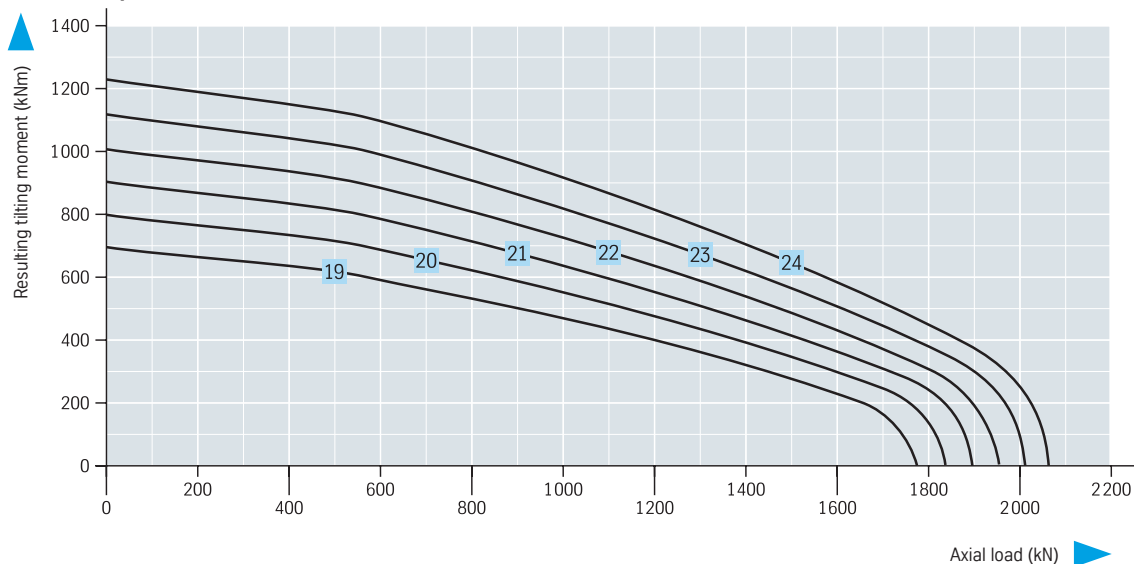

Series 25, 23, 28 profile bearing

Standard Series type 110, Bearing with restricted play

Bearing with external gearing		Geometry								Attachment		
Drawing number		$\varnothing D_L$ mm	$\varnothing D_a$ mm	$\varnothing D_i$ mm	H mm	$\varnothing O$ mm	$\varnothing U$ mm	$\varnothing C$ mm	H_u mm	$\varnothing L_a$ mm	n_a	M mm
19	281.30.0975.013 Type 110/1100.1	955	1096,2	807 + 0,14	90	956,5	955 + 0,14	893	19	1016	30	20
20	281.30.1075.013 Type 110/1200.1	1055	1198	907 + 0,14	90	1056,5	1055 + 0,17	993	19	1116	30	20
21	281.30.1175.013 Type 110/1300.1	1155	1298	1007 + 0,17	90	1156,5	1155 + 0,17	1093	19	1216	36	20
22	281.30.1275.013 Type 110/1400.1	1255	1398	1107 + 0,17	90	1256,5	1255 + 0,20	1193	19	1316	42	20
23	281.30.1375.013 Type 110/1500.1	1355	1498	1207 + 0,17	90	1356,5	1355 + 0,20	1293	19	1416	42	20
24	281.30.1475.013 Type 110/1600.1	1455	1598	1307 + 0,20	90	1456,5	1455 + 0,20	1393	19	1516	48	20

$\varnothing D_a$ from 1991 tip relief 0,1 · m

Centering height $H_z^* = 13$ mm
Centering height of the companion structure = $(H_z - 1)$ mm

Raceway read-off loads for static boundary load curves and utilization period curves must be found with load factors acc. to Table 1, page 61.

Static boundary load curves

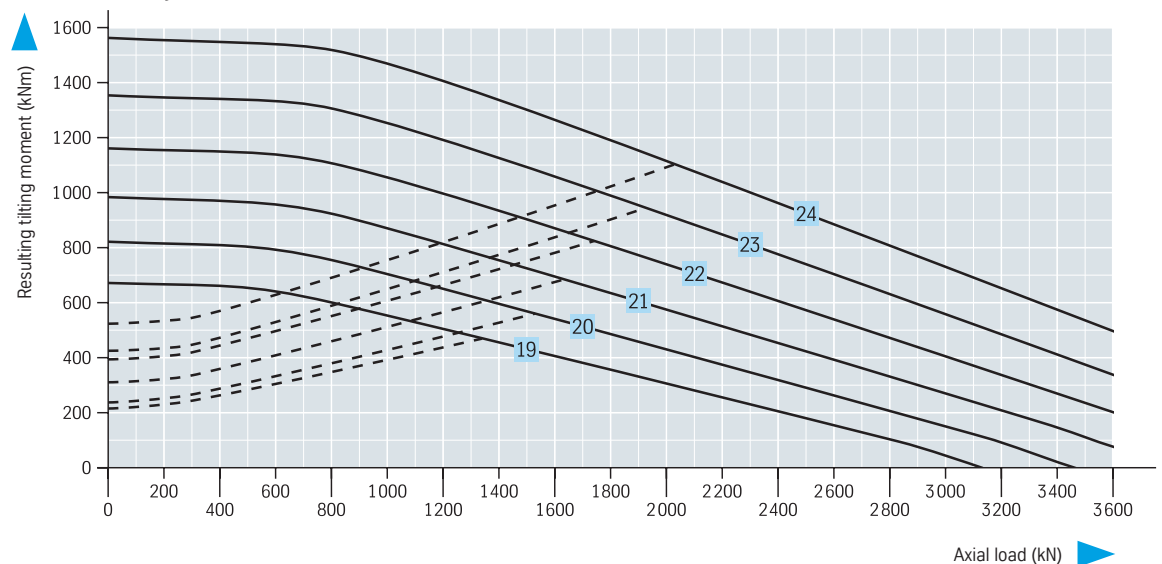

Attachment				Gearing						Miscellaneous			
t mm	Ø L ₁ mm	n ₁	Ø B mm	d mm	m mm	z	k · m mm	b mm	X1 kN	X2 kN	kg	n ₁	Y axial + radial mm
40	845	30	22	1080	9	120	-0,9	71	32,76	65,52	165	6	≥ 0 to 0,06
40	945	30	22	1180	10	118	-1,0	71	36,40	72,80	183	6	≥ 0 to 0,06
40	1045	36	22	1280	10	128	-1,0	71	36,40	72,80	200	6	≥ 0 to 0,06
40	1145	42	22	1380	10	138	-1,0	71	36,40	72,80	216	6	≥ 0 to 0,07
40	1245	42	22	1480	10	148	-1,0	71	36,40	72,80	234	6	≥ 0 to 0,07
40	1345	48	22	1580	10	158	-1,0	71	36,40	72,80	250	6	≥ 0 to 0,07

► n₁ = Tapered grease nipple
AM 8 x 1 DIN 71412
≈ evenly distributed

Diameter tolerances

Machined diameters with untoleranced drawing dimensions have the following tolerances:

- ≤ 1000 mm ± 2,5 mm
- ≤ 2000 mm ± 3,5 mm

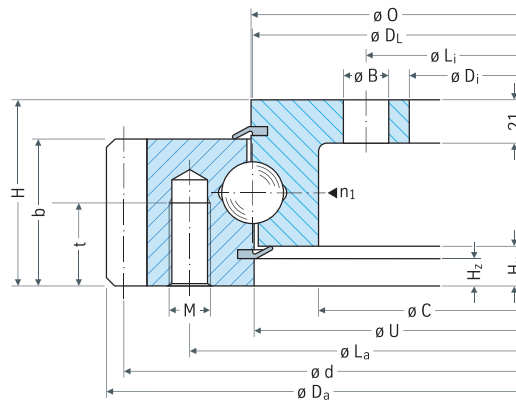

Bearing selection series 25, 23, 28

Utilization period curves – 30 000 revolutions

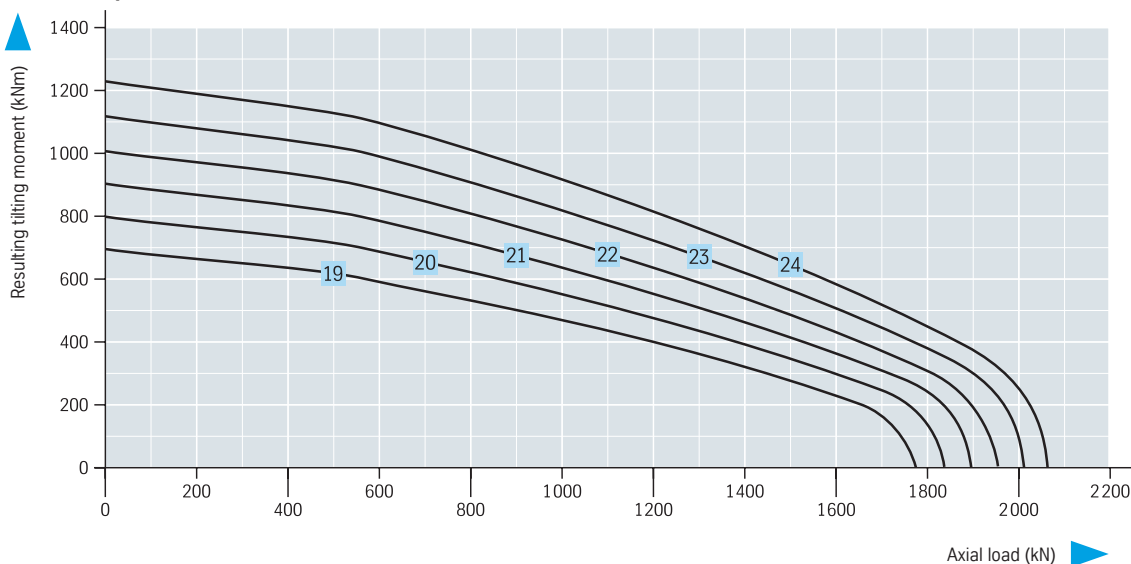

Series 25, 23, 28 profile bearing

Standard Series type 110, Bearing with restricted play

Bearing with internal gearing		Geometry							Attachment			
Drawing number		$\varnothing D_L$ mm	$\varnothing D_a$ mm	$\varnothing D_i$ mm	H mm	$\varnothing O$ mm	$\varnothing U$ mm	$\varnothing A$ mm	H_u mm	$\varnothing L_a$ mm	n_a	$\varnothing B$ mm
19	282.30.0975.013 Type 110/1100.2	955	1098 -0,17	812	90	955 -0,14	953,5	1017	19	1060	30	22
20	282.30.1075.013 Type 110/1200.2	1055	1198 -0,17	912	90	1055 -0,17	1053,5	1117	19	1160	30	22
21	282.30.1175.013 Type 110/1300.2	1155	1298 -0,20	1012	90	1155 -0,17	1153,5	1217	19	1260	36	22
22	282.30.1275.013 Type 110/1400.2	1255	1398 -0,20	1112	90	1255 -0,20	1253,5	1317	19	1360	42	22
23	282.30.1375.013 Type 110/1500.2	1355	1498 -0,20	1212	90	1355 -0,20	1353,5	1417	19	1460	42	22
24	282.30.1475.013 Type 110/1600.2	1455	1598 -0,20	1310	90	1455 -0,20	1453,5	1517	19	1560	48	22

Centering height $H_z^* = 13$ mm
 Centering height of the companion structure = $(H_z - 1)$ mm

Raceway read-off loads for static boundary load curves and utilization period curves must be found with load factors acc. to Table 1, page 61.

Static boundary load curves

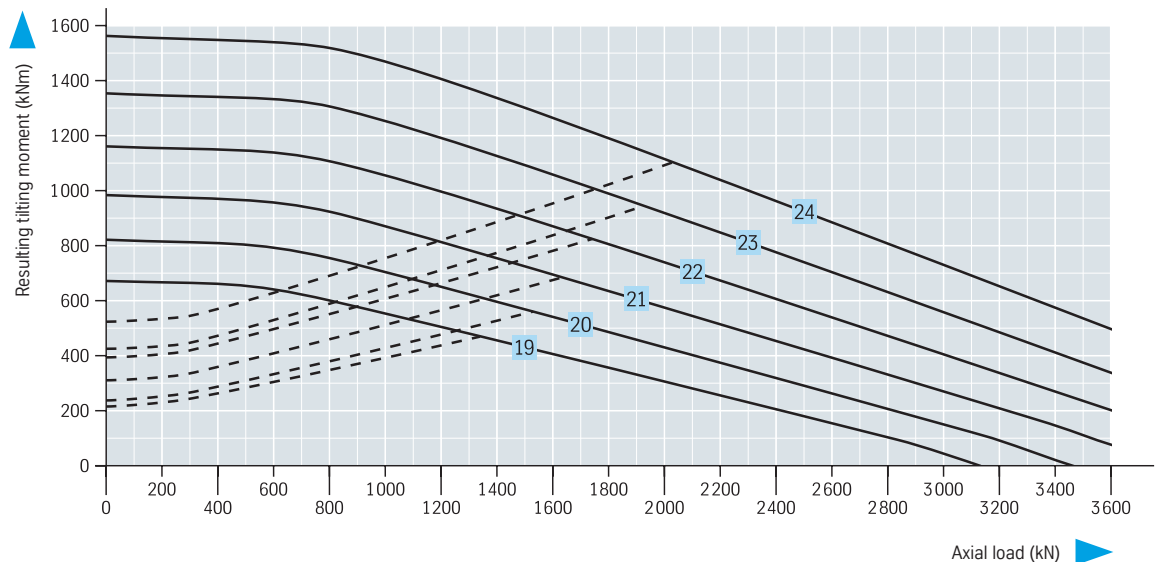

Attachment				Gearing						Miscellaneous			
$\emptyset L_1$ mm	n_1	M mm	t mm	d mm	m mm	z	k · m mm	b mm	X1 kN	X2 kN	 kg	n_1	Y axial + radial mm
894	30	20	40	830	10	83	- 1,0	71	40,60	81,20	159	6	≥ 0 to 0,06
994	30	20	40	930	10	93	- 1,0	71	40,06	80,12	176	6	≥ 0 to 0,06
1094	36	20	40	1030	10	103	- 1,0	71	39,58	79,16	192	6	≥ 0 to 0,06
1194	42	20	40	1130	10	113	- 1,0	71	39,18	78,36	208	6	≥ 0 to 0,07
1294	42	20	40	1230	10	123	- 1,0	71	38,83	77,66	226	6	≥ 0 to 0,07
1394	48	20	40	1330	10	133	—	71	38,55	77,10	243	6	≥ 0 to 0,07

► n_1 = Tapered grease nipple
AM 8 x 1 DIN 71412
≈ evenly distributed

Diameter tolerances

Machined diameters with untoleranced drawing dimensions have the following tolerances:

- ≤ 1000 mm ± 2,5 mm
- ≤ 2000 mm ± 3,5 mm

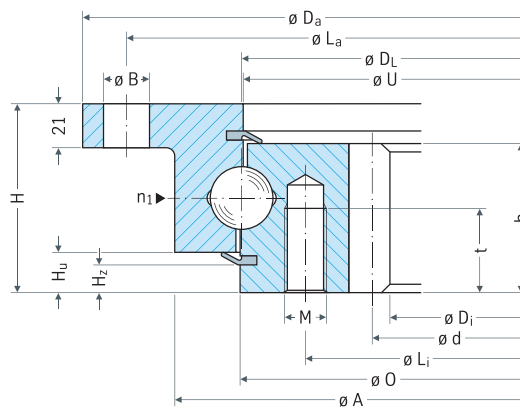

Bearing selection series 25, 23, 28

Utilization period curves – 30 000 revolutions

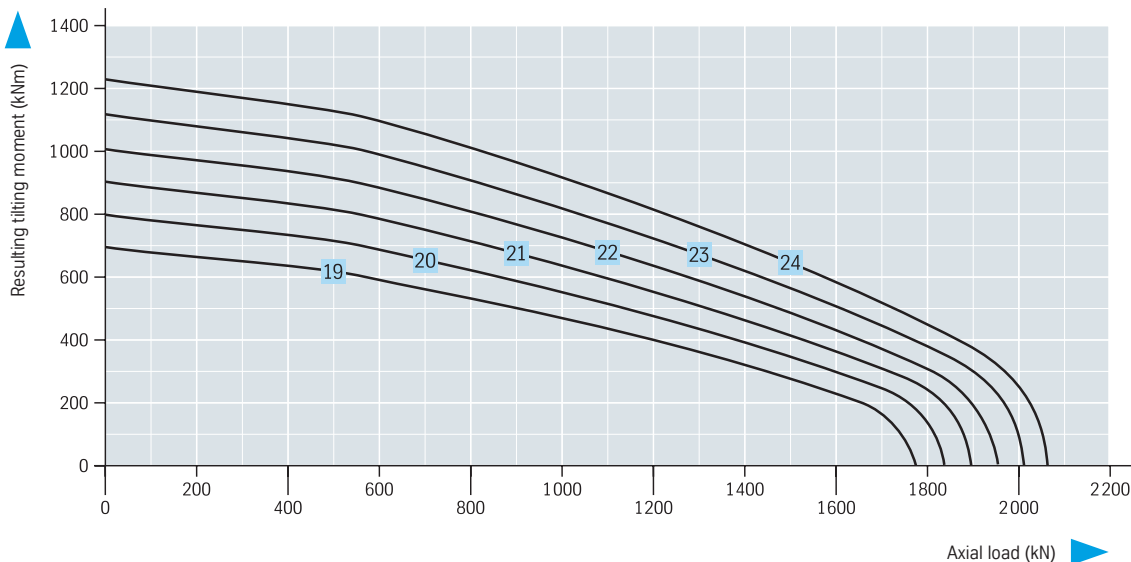

Series 06

Single-row four-point bearing

Bearing without gearing		Geometry									
Drawing number		$\varnothing D_L$ mm	$\varnothing D_a$ mm	$\varnothing D_i$ mm	H mm	$\varnothing O$ mm	$\varnothing U$ mm	H_1 mm	H_2 mm	H_u mm	H_o mm
1	060.22.0370.301.11.1504	370	456	289	59	371	369	50	50	9	9
2	060.22.0505.000.11.1503	505	585	425	58	506	504	49	49	9	9
3	060.22.0575.502.11.1503	575	655	500	62	576	574	49	49	13	13
4	060.22.0660.001.11.1503	660	740	580	58	657	659	49	49	9	9

Drawing number
060.22.0575.502.11.1503

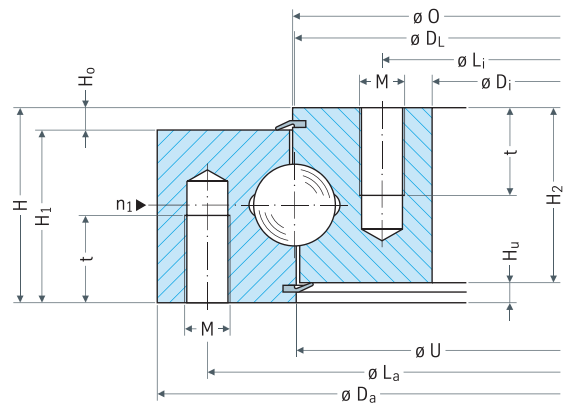

Static boundary load curves

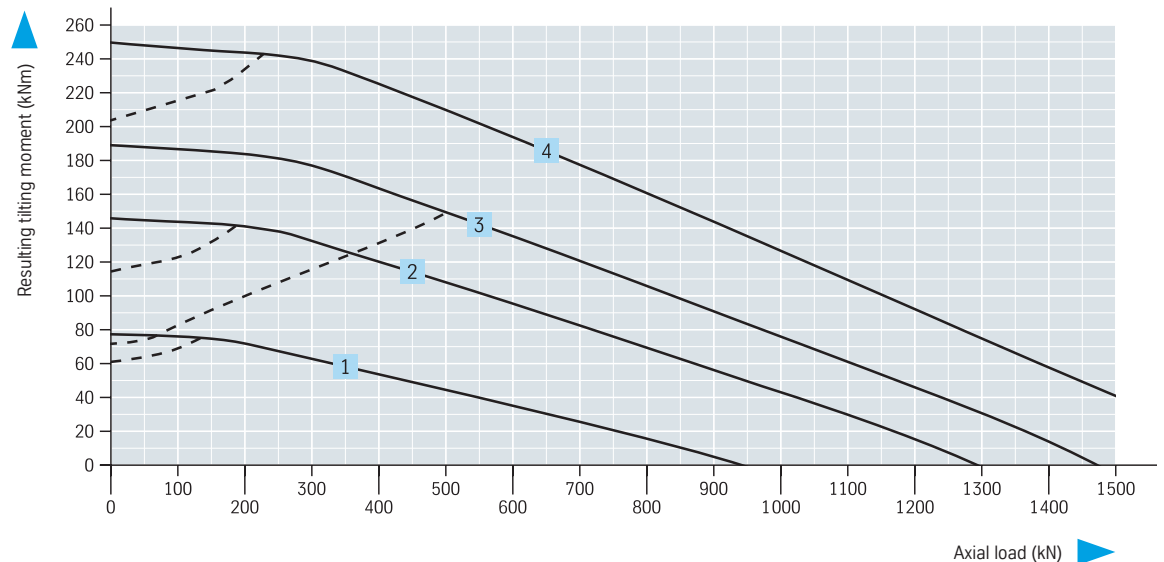

Attachment					Miscellaneous	
$\varnothing L_a$ mm	$\varnothing L_i$ mm	n	$\varnothing B$ mm	M mm	 kg	n_1
425	320	16	17,5	16	35	4
555	455	22	17,5	16	44	2
625	525	12	—	16	52	4
710	610	30	17,5	16	59	2

Drawing number

060.22.0370.301.11.1504

060.22.0505.000.11.1503

060.22.0660.001.11.1503

Diameter tolerances

Machined diameters with untoleranced drawing dimensions have the following tolerances:

≤ 315 mm ± 1,6 mm

≤ 1000 mm ± 2,5 mm

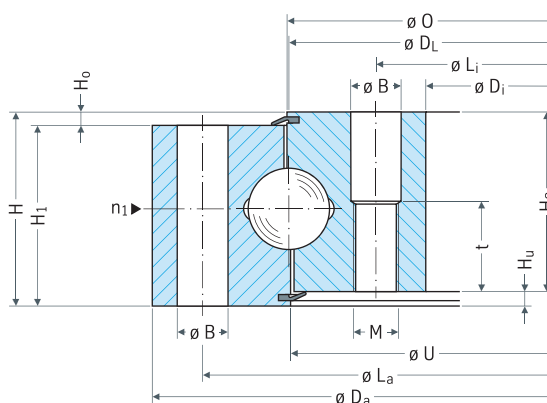

Bearing selection series 06

Utilization period curves – 30 000 revolutions

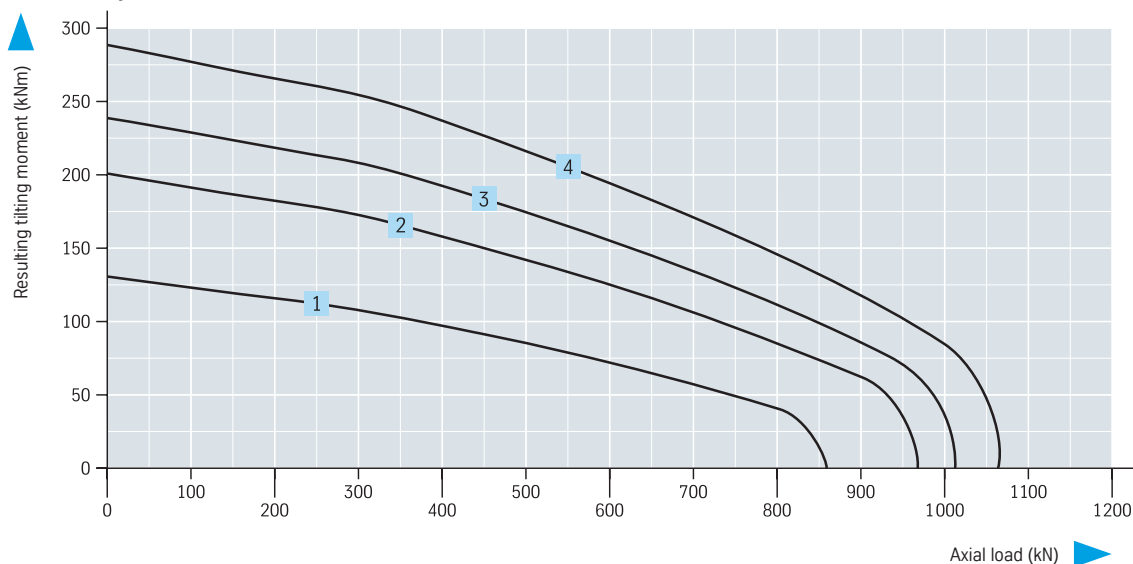

Series 06 Single-row four-point bearing

Bearing without gearing		Geometry									
Drawing number		$\varnothing D_L$ mm	$\varnothing D_a$ mm	$\varnothing D_I$ mm	H mm	$\varnothing O$ mm	$\varnothing U$ mm	H ₁ mm	H ₂ mm	H _u mm	H _o mm
5	060.25.0475.000.11.1504	475	565	385	64	476	474	57	57	7	7
6	060.25.0555.000.11.1504	555	650	460	63	556	554	54	54	9	9
7	060.30.0550.100.11.1504	555	650	450	75	548	552	65	65	10	10
8	060.35.0680.000.11.1503	680	800	560	82	681	678	73	73	9	9
9	060.45.0805.001.11.1504	805	948	662	99	807	803	90	90	9	9

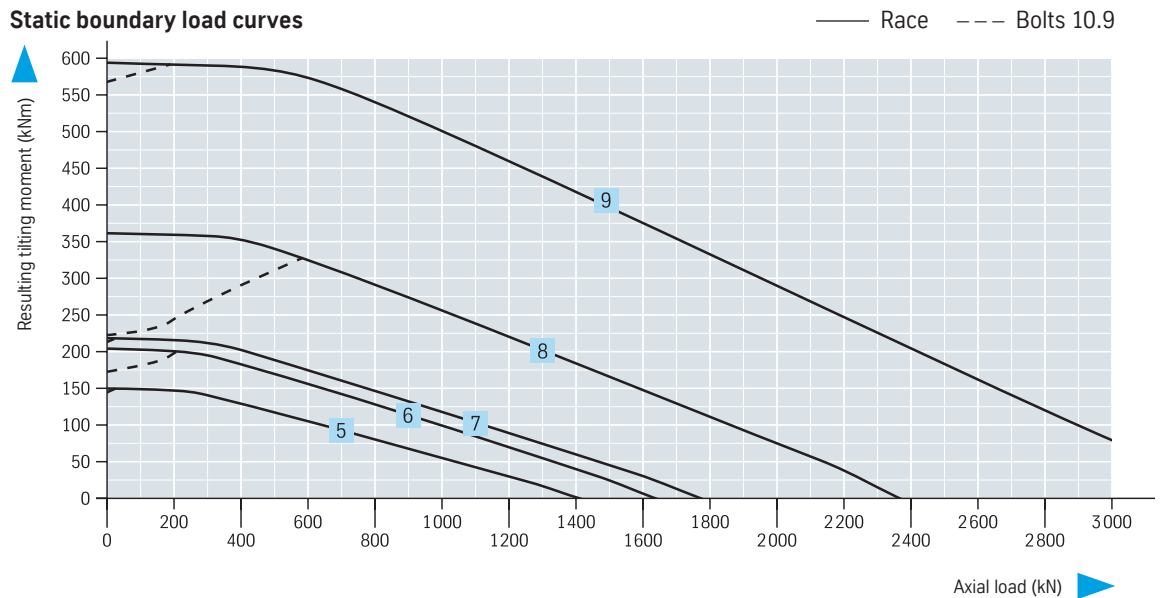

Attachment					Miscellaneous	
$\varnothing L_a$ mm	$\varnothing L_i$ mm	n	$\varnothing B$ mm	M mm	 kg	n_1
535	415	30	17,5	16	50	3
614	496	30	17,5	16	61	3
615	485	24	22,0	20	73	4
755	605	20	22,0	20	131	4
896	714	30	26,0	24	215	4

Diameter tolerances

Machined diameters with untoleranced drawing dimensions have the following tolerances:

$\leq 1000 \text{ mm} \pm 2,5 \text{ mm}$

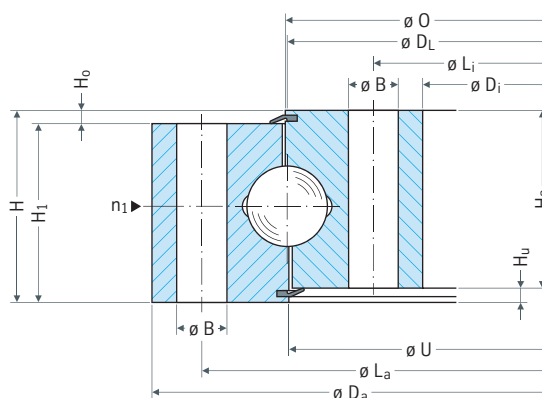

Bearing selection series 06

Utilization period curves – 30 000 revolutions

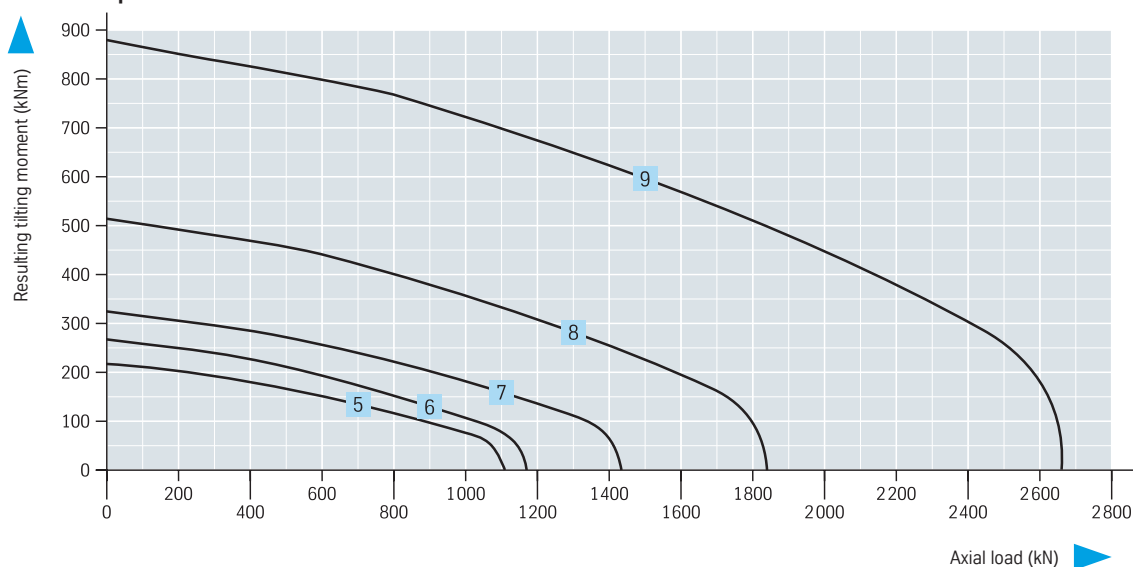

Series 06 Single-row four-point bearing

Standard Series type 621, Normal bearing

Bearing without gearing		Geometry									
Drawing number		$\varnothing D_L$ mm	$\varnothing D_a$ mm	$\varnothing D_i$ mm	H mm	$\varnothing O$ mm	$\varnothing U$ mm	H ₁ mm	H ₂ mm	H _u mm	H _o mm
1	060.20.0414.500.01.1503	414	486	342	56	412,5	415,5	45,5	45,5	10,5	10,5
2	060.20.0544.500.01.1503	544	616	472	56	542,5	545,5	45,5	45,5	10,5	10,5
3	060.20.0644.500.01.1503	644	716	572	56	642,5	645,5	45,5	45,5	10,5	10,5
4	060.20.0744.500.01.1503	744	816	672	56	742,5	745,5	45,5	45,5	10,5	10,5
5	060.20.0844.500.01.1503	844	916	772	56	842,5	845,5	45,5	45,5	10,5	10,5
6	060.20.0944.500.01.1503	944	1016	872	56	942,5	945,5	45,5	45,5	10,5	10,5
7	060.20.1094.500.01.1503	1094	1166	1022	56	1092,5	1095,5	45,5	45,5	10,5	10,5

centering spigots are required, these must be specified when the order is placed. Centering spigots are only possible if * is indicated for the nominal \varnothing .

Dimensions of these centering spigots:

D_L 414, 544
 D_L 644, 744, 844
 D_L 944, 1094

outside

- 0,5 mm
- 0,6 mm
- 0,7 mm

inside

+ 0,5 mm
+ 0,6 mm
+ 0,7 mm

Centering height

H_i = 10 mm
H_A = 10 mm

Centering height of the companion structure
max. 9 mm

Static boundary load curves

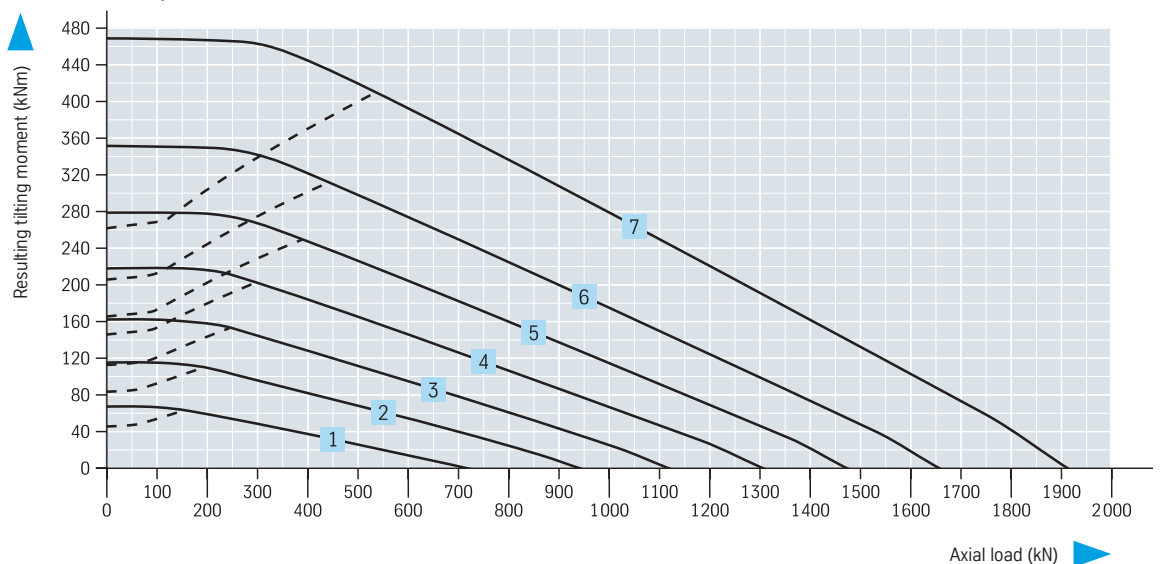

Attachment					Miscellaneous		
$\varnothing L_a$ mm	$\varnothing L_i$ mm	n	$\varnothing B$ mm	M mm	 kg	Y axial mm	Y radial mm
460	368	24	13,5	12	29	≤ 0,28	≤ 0,24
590	498	32	13,5	12	37	≤ 0,30	≤ 0,26
690	598	36	13,5	12	44	≤ 0,30	≤ 0,26
790	698	40	13,5	12	52	≤ 0,30	≤ 0,26
890	798	40	13,5	12	60	≤ 0,30	≤ 0,26
990	898	44	13,5	12	67	≤ 0,30	≤ 0,26
1140	1048	48	13,5	12	77	≤ 0,30	≤ 0,26

► n_1 = 4 Tapered grease nipple
AM 10 x 1 DIN 71412
countersunk and
evenly distributed

Diameter tolerances

Machined diameters with untoleranced drawing dimensions have the following tolerances:

- ≤ 1000 mm ± 2,5 mm
- ≤ 2000 mm ± 3,5 mm

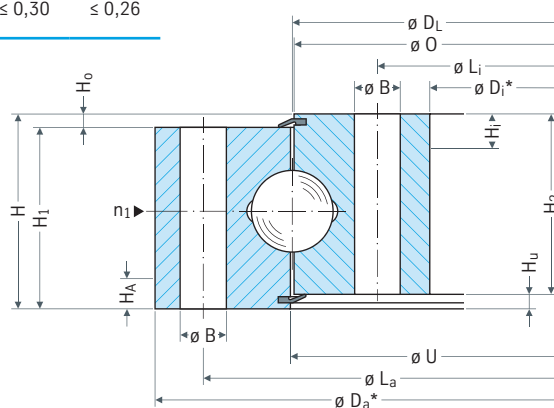

Bearing selection series 06

Utilization period curves – 30 000 revolutions

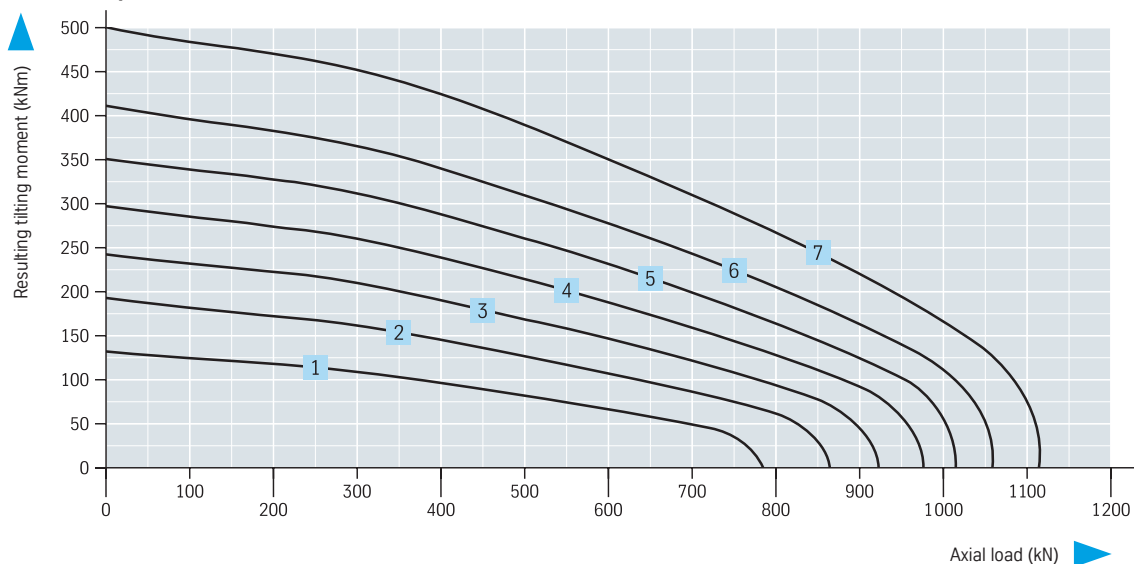

Series 06 Single-row four-point bearing

Standard Series type 621, Normal bearing

Bearing with external gearing		Geometry									
Drawing number		$\varnothing D_L$ mm	$\varnothing D_a$ mm	$\varnothing D_i$ mm	H mm	$\varnothing O$ mm	$\varnothing U$ mm	H_1 mm	H_2 mm	H_u mm	H_o mm
1	061.20.0414.500.01.1503	414	504,0	342	56	412,5	415,5	45,5	45,5	10,5	10,5
2	061.20.0544.500.01.1503	544	640,8	472	56	542,5	545,5	45,5	45,5	10,5	10,5
3	061.20.0644.500.01.1503	644	742,8	572	56	642,5	645,5	45,5	45,5	10,5	10,5
4	061.20.0744.500.01.1503	744	838,8	672	56	742,5	745,5	45,5	45,5	10,5	10,5
5	061.20.0844.500.01.1503	844	950,4	772	56	842,5	845,5	45,5	45,5	10,5	10,5
6	061.20.0944.500.01.1503	944	1046,4	872	56	942,5	945,5	45,5	45,5	10,5	10,5
7	061.20.1094.500.01.1503	1094	1198,4	1022	56	1092,5	1095,5	45,5	45,5	10,5	10,5

If centering spigots are required, these must be specified when the order is placed. Centering spigots are only possible if * is indicated for the nominal \varnothing .

Dimensions of these centering spigots:

DL 414, 544
DL 644, 744, 844
DL 944, 1094

outside

- 0,5 mm
- 0,6 mm
- 0,7 mm

inside

+ 0,5 mm
+ 0,6 mm
+ 0,7 mm

Centering height

$H_i = 10 \text{ mm}$
 $H_z = 4,5 \text{ mm}$

Centering height of the companion structure

max. $H_i -1 \text{ mm}$
max. $H_z -1 \text{ mm}$

Static boundary load curves

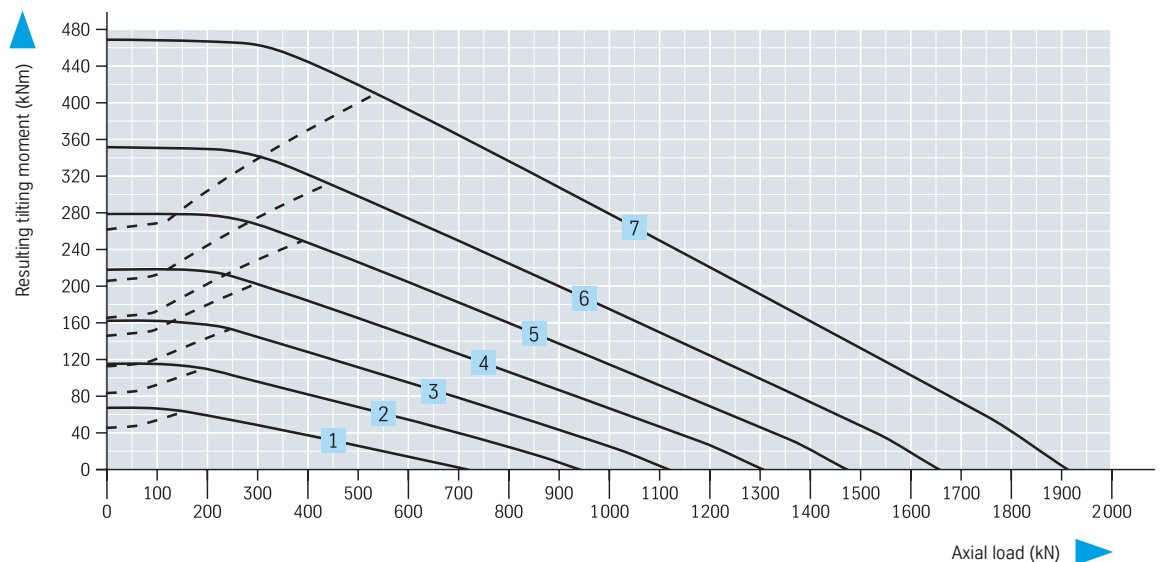

Attachment						Gearing							Miscellaneous		
$\emptyset L_a$ mm	$\emptyset L_l$ mm	n L_a/L_l	$\emptyset B$ mm	M mm	t mm	d mm	m mm	z	k · m mm	b mm	X1 kN	X2 kN	 kg	Y axial mm	Y radial mm
455	368	20/24	13,5	12	20	495	5	99	-0,5	45,5	11,75	23,50	31	≤ 0,28	≤ 0,24
585	498	28/32	13,5	12	20	630	6	105	-0,6	45,5	14,20	28,40	43	≤ 0,30	≤ 0,26
685	598	32/36	13,5	12	20	732	6	122	-0,6	45,5	14,20	28,40	52	≤ 0,30	≤ 0,26
785	698	36/40	13,5	12	20	828	6	138	-0,6	45,5	14,20	28,40	59	≤ 0,30	≤ 0,26
885	798	36/40	13,5	12	20	936	8	117	-0,8	45,5	18,93	37,86	71	≤ 0,30	≤ 0,26
985	898	40/44	13,5	12	20	1032	8	129	-0,8	45,5	18,93	37,86	77	≤ 0,30	≤ 0,26
1135	1048	44/48	13,5	12	20	1184	8	148	-0,8	45,5	18,93	37,86	91	≤ 0,30	≤ 0,26

► $n_1 = 4$ Tapered grease nipple
AM 10 x 1 DIN 71412
countersunk and
evenly distributed

Diameter tolerances

Machined diameters with untoleranced
drawing dimensions have the following
tolerances:

- ≤ 1000 mm ± 2,5 mm
- ≤ 2000 mm ± 3,5 mm

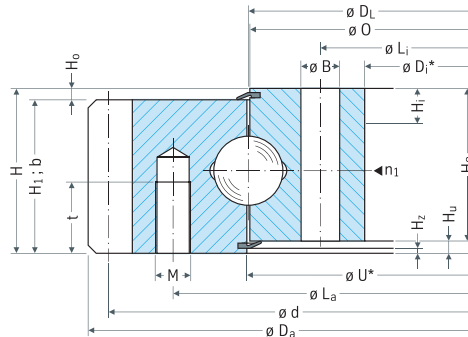

Bearing
selection series
06

Utilization period curves – 30 000 revolutions

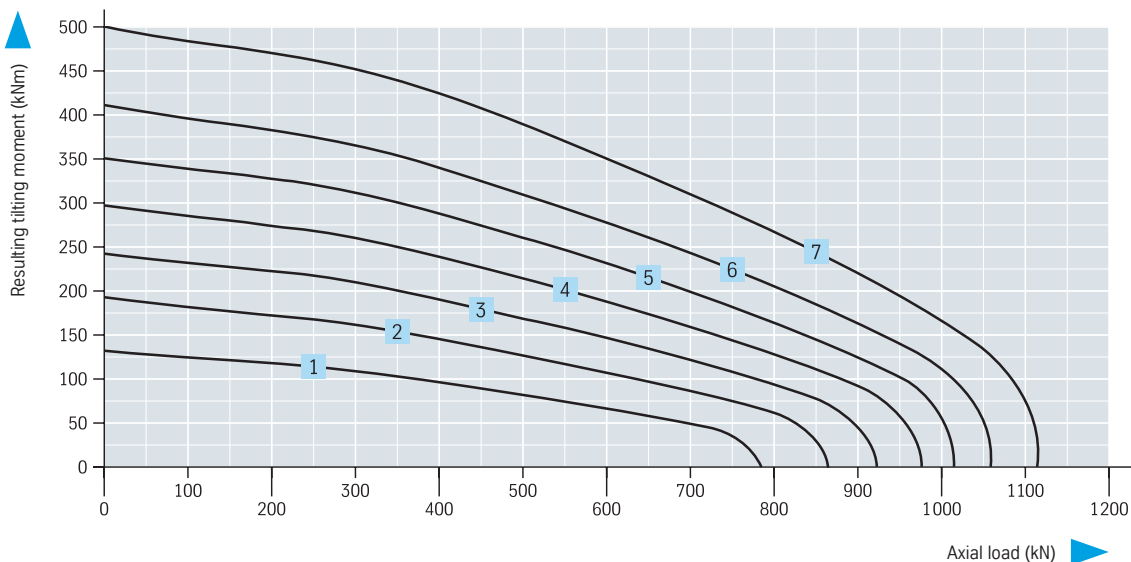

Series 06 Single-row four-point bearing

Standard Series type 621, Normal bearing

Bearing with internal gearing		Geometry									
Drawing number		$\varnothing D_L$ mm	$\varnothing D_a$ mm	$\varnothing D_i$ mm	H mm	$\varnothing O$ mm	$\varnothing U$ mm	H ₁ mm	H ₂ mm	H _u mm	H _o mm
1	062.20.0414.500.01.1503	414	486	326,5	56	415,5	412,5	45,5	45,5	10,5	10,5
2	062.20.0544.500.01.1503	544	616	445,2	56	545,5	542,5	45,5	45,5	10,5	10,5
3	062.20.0644.500.01.1503	644	716	547,2	56	645,5	642,5	45,5	45,5	10,5	10,5
4	062.20.0744.500.01.1503	744	816	649,2	56	745,5	742,5	45,5	45,5	10,5	10,5
5	062.20.0844.500.01.1503	844	916	737,6	56	845,5	842,5	45,5	45,5	10,5	10,5
6	062.20.0944.500.01.1503	944	1016	841,6	56	945,5	942,5	45,5	45,5	10,5	10,5
7	062.20.1094.500.01.1503	1094	1166	985,6	56	1095,5	1092,5	45,5	45,5	10,5	10,5

If centering spigots are required, these must be specified when the order is placed. Centering spigots are only possible if * is indicated for the nominal \varnothing .

Dimensions of these centering spigots:

DL 414, 544
DL 644, 744, 844
DL 944, 1094

outside

- 0,5 mm
- 0,6 mm
- 0,7 mm

inside

+ 0,5 mm
+ 0,6 mm
+ 0,7 mm

Centering height

H_Z = 4,5 mm
H_A = 10 mm

Centering height of the companion structure

max. H_Z -1 mm
max. H_A -1 mm

Static boundary load curves

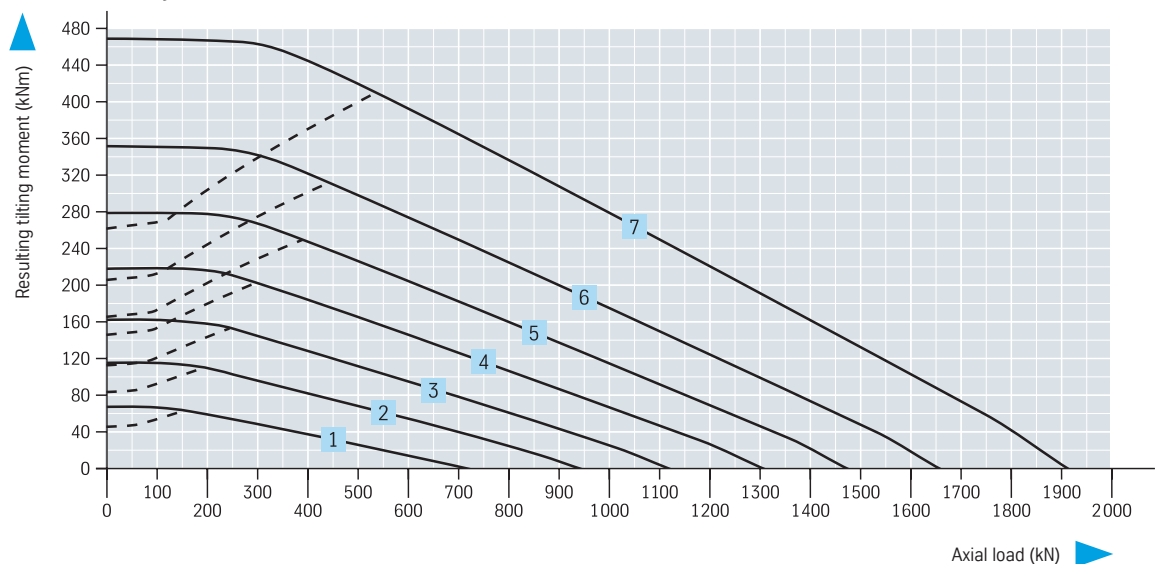

Attachment						Gearing							Miscellaneous		
$\emptyset L_a$ mm	$\emptyset L_l$ mm	n	$\emptyset B$ mm	M mm	t mm	d mm	m mm	z	k · m mm	b mm	X1 kN	X2 kN	kg	Y axial mm	Y radial mm
460	375	24	13,5	12	20	335	5	67	-0,75	45,5	13,54	27,08	31	≤ 0,28	≤ 0,28
590	505	32	13,5	12	20	456	6	76	-0,60	45,5	16,00	32,00	42	≤ 0,30	≤ 0,30
690	605	36	13,5	12	20	558	6	93	-0,60	45,5	15,62	31,24	50	≤ 0,30	≤ 0,30
790	705	40	13,5	12	20	660	6	110	-0,60	45,5	15,32	30,64	58	≤ 0,30	≤ 0,30
890	805	40	13,5	12	20	752	8	94	-0,80	45,5	20,80	41,60	69	≤ 0,30	≤ 0,30
990	905	44	13,5	12	20	856	8	107	-0,80	45,5	20,49	40,98	76	≤ 0,30	≤ 0,30
1140	1055	48	13,5	12	20	1000	8	125	-0,80	45,5	20,16	40,32	91	≤ 0,30	≤ 0,30

► $n_1 = 4$ Tapered grease nipple
AM 10 x 1 DIN 71412
countersunk and
evenly distributed

Diameter tolerances

Machined diameters with untoleranced
drawing dimensions have the following
tolerances:

- ≤ 1000 mm ± 2,5 mm
- ≤ 2000 mm ± 3,5 mm

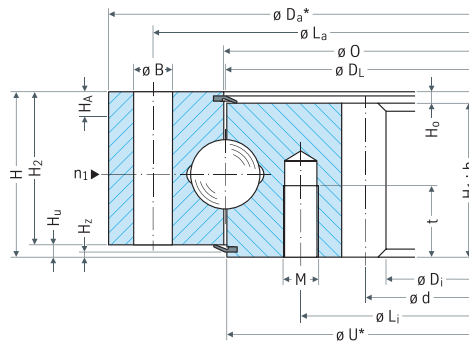

Bearing
selection series
06

Utilization period curves – 30 000 revolutions

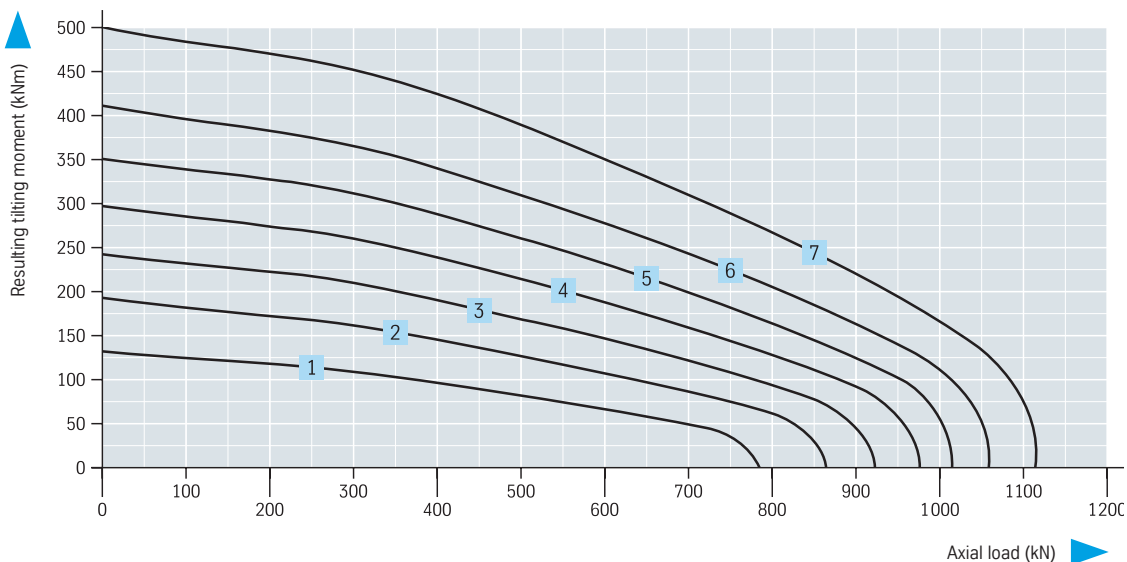

Series 06 Single-row four-point bearing

Standard Series type 621, Bearing with restricted play

Bearing without gearing		Geometry									
Drawing number		$\varnothing D_L$ mm	$\varnothing D_a$ mm	$\varnothing D_i$ mm	H mm	$\varnothing O$ mm	$\varnothing U$ mm	H ₁ mm	H ₂ mm	H _u mm	H _o mm
1	060.20.0414.575.01.1403	414	484,5 -0,10	343,5 +0,09	56	412,5	415,5	45,5	45,5	10,5	10,5
2	060.20.0544.575.01.1403	544	614,5 -0,11	473,5 +0,10	56	542,5	545,5	45,5	45,5	10,5	10,5
3	060.20.0644.575.01.1403	644	714,5 -0,13	573,5 +0,11	56	642,5	645,5	45,5	45,5	10,5	10,5
4	060.20.0744.575.01.1403	744	814,5 -0,14	673,5 +0,13	56	742,5	745,5	45,5	45,5	10,5	10,5
5	060.20.0844.575.01.1403	844	914,5 -0,14	773,5 +0,13	56	842,5	845,5	45,5	45,5	10,5	10,5
6	060.20.0944.575.01.1403	944	1014,5 -0,17	873,5 +0,14	56	942,5	945,5	45,5	45,5	10,5	10,5
7	060.20.1094.575.01.1403	1094	1164,5 -0,17	1023,5 +0,17	56	1092,5	1095,5	45,5	45,5	10,5	10,5

* Tolerance data applies in each case to H_i, H_A

Centering height

H_i = 10 mm

H_A = 10 mm

Centering height

of the companion

structure

max. 9 mm

Static boundary load curves

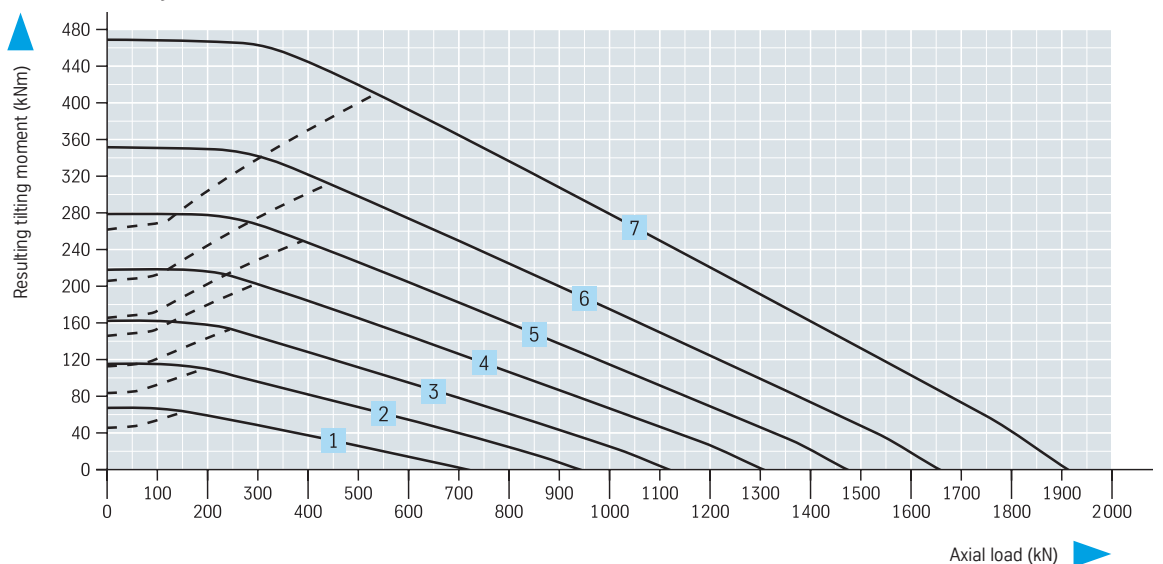

Attachment					Miscellaneous	
$\varnothing L_a$ mm	$\varnothing L_i$ mm	n^*	$\varnothing B$ mm	M mm	 kg	Y axial + radial mm
460	368	24	13,5	12	29	≥ 0 to 0,03
590	498	32	13,5	12	37	≥ 0 to 0,03
690	598	36	13,5	12	44	≥ 0 to 0,04
790	698	40	13,5	12	52	≥ 0 to 0,04
890	798	40	13,5	12	60	≥ 0 to 0,05
990	898	44	13,5	12	67	≥ 0 to 0,05
1140	1048	48	13,5	12	77	≥ 0 to 0,06

► $n_1 = 4$ Tapered grease nipple
AM 10 x 1 DIN 71412
countersunk and
evenly distributed

Diameter tolerances

Machined diameters with untoleranced
drawing dimensions have the following
tolerances:

- ≤ 1000 mm $\pm 2,5$ mm
- ≤ 2000 mm $\pm 3,5$ mm

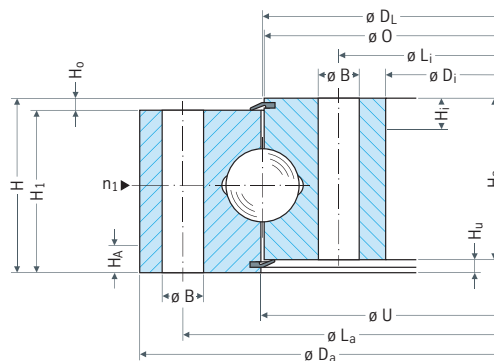

Bearing
selection series
06

Utilization period curves – 30 000 revolutions

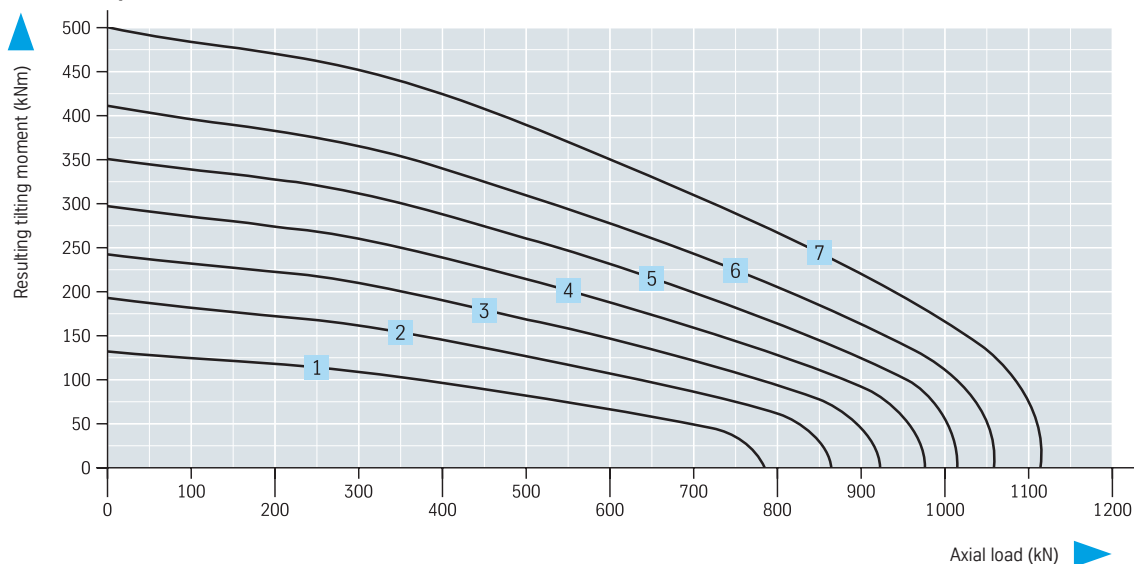

Series 06 Single-row four-point bearing

Standard Series type 621, Bearing with restricted play

Bearing with external gearing		Geometry									
Drawing number		$\varnothing D_L$ mm	$\varnothing D_a$ mm	$\varnothing D_i$ mm	H mm	$\varnothing O$ mm	$\varnothing U$ mm	H_1 mm	H_2 mm	H_u mm	H_o mm
1	061.20.0414.575.01.1403	414	504,0	343,5 +0,09	56	412,5	417 +0,10	45,5	45,5	10,5	10,5
2	061.20.0544.575.01.1403	544	640,8	473,5 +0,10	56	542,5	547 +0,11	45,5	45,5	10,5	10,5
3	061.20.0644.575.01.1403	644	742,8	573,5 +0,11	56	642,5	647 +0,13	45,5	45,5	10,5	10,5
4	061.20.0744.575.01.1403	744	838,8	673,5 +0,13	56	742,5	747 +0,13	45,5	45,5	10,5	10,5
5	061.20.0844.575.01.1403	844	950,4	773,5 +0,13	56	842,5	847 +0,14	45,5	45,5	10,5	10,5
6	061.20.0944.575.01.1403	944	1046,4	873,5 +0,14	56	942,5	947 +0,14	45,5	45,5	10,5	10,5
7	061.20.1094.575.01.1403	1094	1198,4	1023,5 +0,17	56	1092,5	1097 +0,17	45,5	45,5	10,5	10,5

* Tolerance data applies in each case to H_1, H_2

Centering height
 $H_1 = 10 \text{ mm}$
 $H_2 = 4,5 \text{ mm}$

Centering height of the companion structure
max. $H_1 -1 \text{ mm}$
max. $H_2 -1 \text{ mm}$

Static boundary load curves

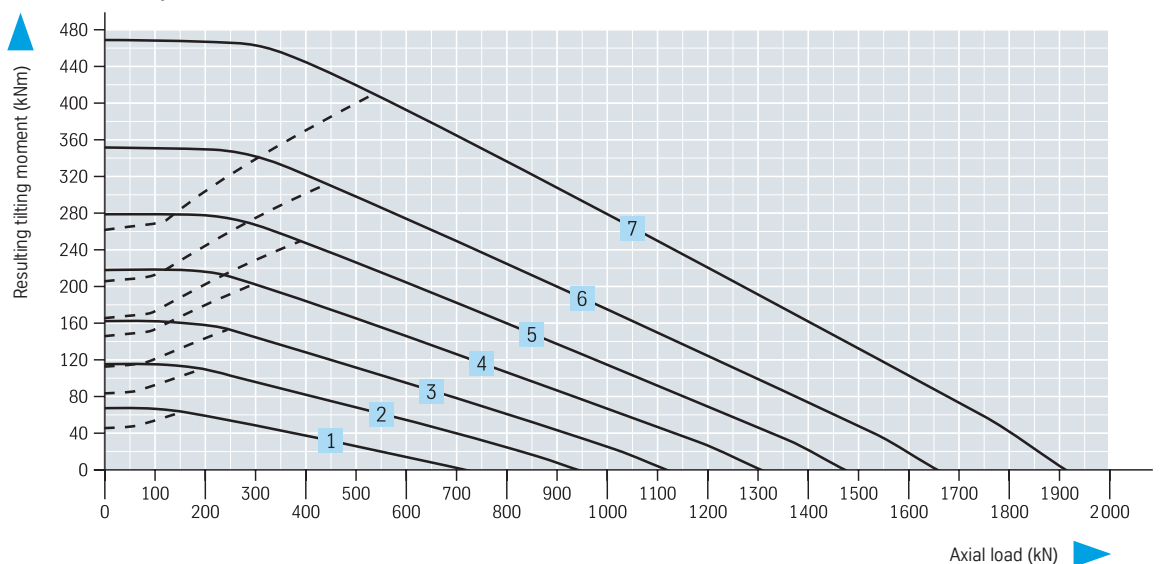

Attachment						Gearing							Miscellaneous	
$\emptyset L_a$ mm	$\emptyset L_l$ mm	n L_a/L_l	$\emptyset B$ mm	M mm	t mm	d mm	m mm	z	$k \cdot m$ mm	b mm	X1 kN	X2 kN	 kg	Y axial + radial mm
455	368	20/24	13,5	12	20	495	5	99	-0,5	45,5	11,75	23,50	31	≥ 0 to 0,03
585	498	28/32	13,5	12	20	630	6	105	-0,6	45,5	14,20	28,40	43	≥ 0 to 0,03
685	598	32/36	13,5	12	20	732	6	122	-0,6	45,5	14,20	28,40	52	≥ 0 to 0,04
785	698	36/40	13,5	12	20	828	6	138	-0,6	45,5	14,20	28,40	59	≥ 0 to 0,04
885	798	36/40	13,5	12	20	936	8	117	-0,8	45,5	18,93	37,86	71	≥ 0 to 0,05
985	898	40/44	13,5	12	20	1032	8	129	-0,8	45,5	18,93	37,86	77	≥ 0 to 0,05
1135	1048	44/48	13,5	12	20	1184	8	148	-0,8	45,5	18,93	37,86	91	≥ 0 to 0,06

► $n_1 = 4$ Tapered grease nipple
AM 10 x 1 DIN 71412
countersunk and
evenly distributed

Diameter tolerances

Machined diameters with untoleranced
drawing dimensions have the following
tolerances:

- ≤ 1000 mm ± 2,5 mm
- ≤ 2000 mm ± 3,5 mm

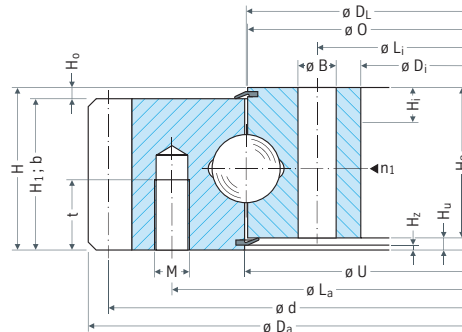

Bearing
selection series
06

Utilization period curves – 30 000 revolutions

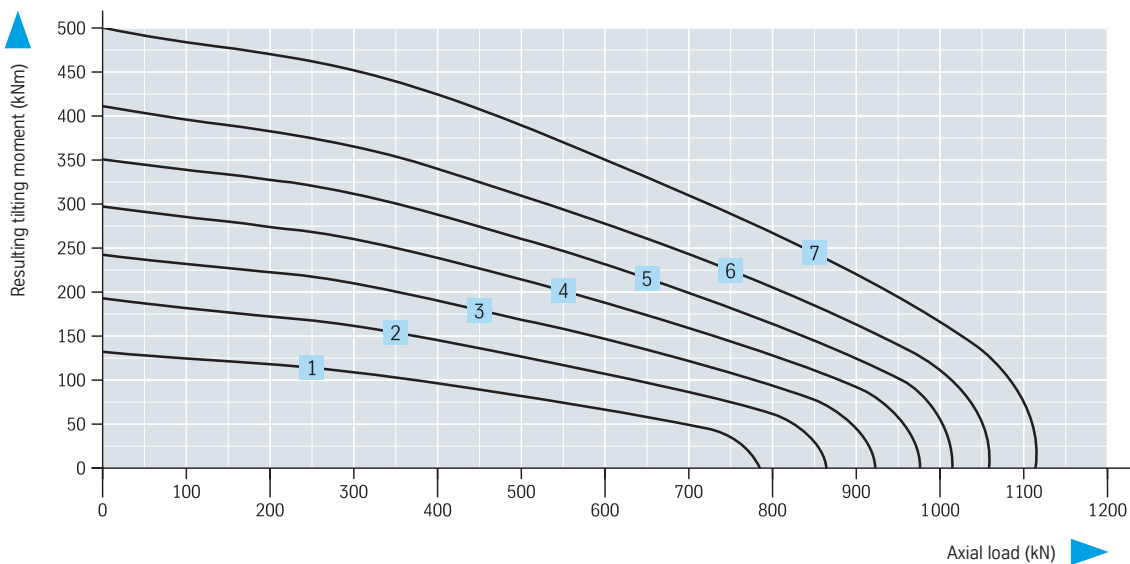

Series 06 Single-row four-point bearing

Standard Series type 621, Bearing with restricted play

Bearing with internal gearing		Geometry									
Drawing number		$\varnothing D_L$ mm	$\varnothing D_a$ mm	$\varnothing D_i$ mm	H mm	$\varnothing O$ mm	$\varnothing U$ mm	H ₁ mm	H ₂ mm	H _u mm	H _o mm
1	062.20.0414.575.01.1403	414	484,5 -0,10	326,5	56	415,5	411 -0,10	45,5	45,5	10,5	10,5
2	062.20.0544.575.01.1403	544	614,5 -0,11	445,2	56	545,5	541 -0,11	45,5	45,5	10,5	10,5
3	062.20.0644.575.01.1403	644	714,5 -0,13	547,2	56	645,5	641 -0,13	45,5	45,5	10,5	10,5
4	062.20.0744.575.01.1403	744	814,5 -0,14	649,2	56	745,5	741 -0,13	45,5	45,5	10,5	10,5
5	062.20.0844.575.01.1403	844	914,5 -0,14	737,6	56	845,5	841 -0,14	45,5	45,5	10,5	10,5
6	062.20.0944.575.01.1403	944	1014,5 -0,17	841,6	56	945,5	941 -0,14	45,5	45,5	10,5	10,5
7	062.20.1094.575.01.1403	1094	1164,5 -0,17	985,6	56	1095,5	1091 -0,17	45,5	45,5	10,5	10,5

* Tolerance data applies in each case to H_A, H_Z

Centering height
H_Z = 4,5 mm
H_A = 10 mm

Centering height of the companion structure
max. H_Z -1 mm
max. H_A -1 mm

Static boundary load curves

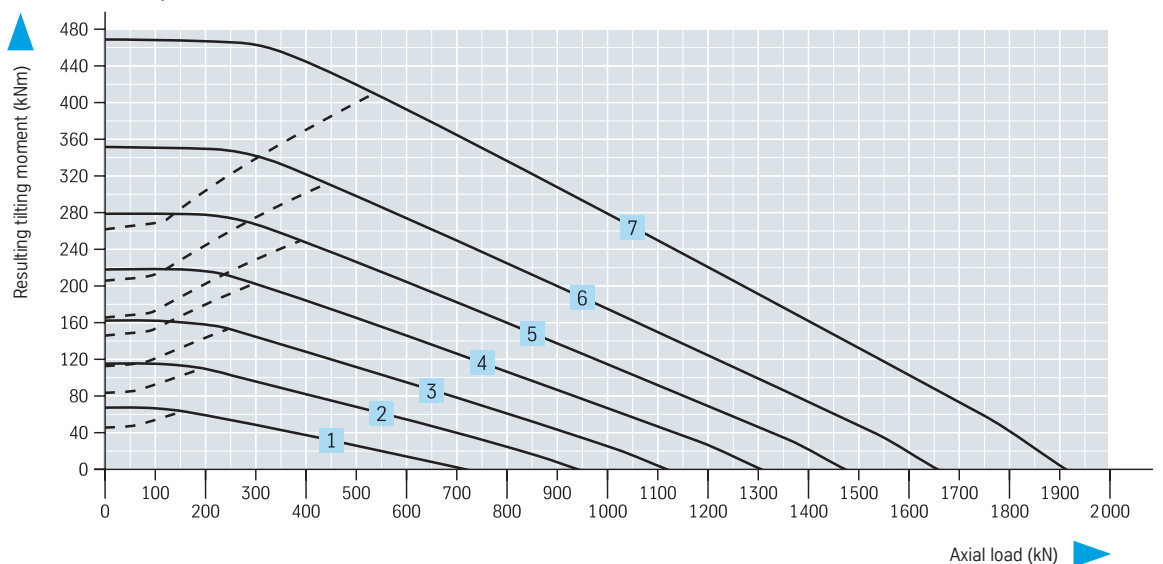

Attachment						Gearing							Miscellaneous	
$\emptyset L_a$ mm	$\emptyset L_l$ mm	n	$\emptyset B$ mm	M mm	t mm	d mm	m mm	z	k · m mm	b mm	X1 kN	X2 kN	kg	Y axial + radial mm
460	375	24	13,5	12	20	335	5	67	-0,75	45,5	13,54	27,08	31	≥ 0 to 0,03
590	505	32	13,5	12	20	456	6	76	-0,60	45,5	16,00	32,00	42	≥ 0 to 0,03
690	605	36	13,5	12	20	558	6	93	-0,60	45,5	15,62	31,24	50	≥ 0 to 0,04
790	705	40	13,5	12	20	660	6	110	-0,60	45,5	15,32	30,64	58	≥ 0 to 0,04
890	805	40	13,5	12	20	752	8	94	-0,80	45,5	20,80	41,60	69	≥ 0 to 0,05
990	905	44	13,5	12	20	856	8	107	-0,80	45,5	20,49	40,98	76	≥ 0 to 0,05
1140	1055	48	13,5	12	20	1000	8	125	-0,80	45,5	20,16	40,32	91	≥ 0 to 0,06

► $n_1 = 4$ Tapered grease nipple
AM 10 x 1 DIN 71412
countersunk and
evenly distributed

Diameter tolerances

Machined diameters with untoleranced
drawing dimensions have the following
tolerances:

- ≤ 1000 mm ± 2,5 mm
- ≤ 2000 mm ± 3,5 mm

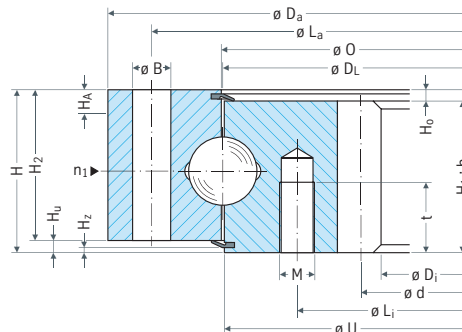

Bearing
selection series
06

Utilization period curves – 30 000 revolutions

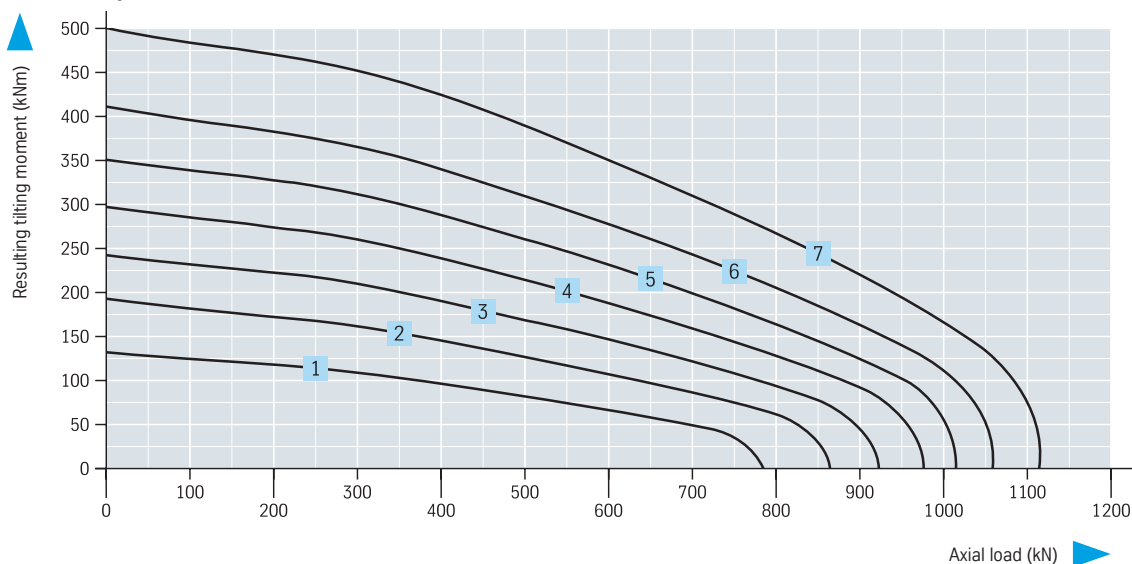

Series 06 Single-row four-point bearing

Standard Series type 625, Normal bearing

Bearing without gearing		Geometry											
Drawing number		$\varnothing D_L$ mm	$\varnothing D_a$ mm	$\varnothing D_i$ mm	H mm	$\varnothing O$ mm	$\varnothing U$ mm	H_1 mm	H_2 mm	H_u mm	H_o mm	$\varnothing D_a^*$ mm	$\varnothing D_i^*$ mm
1	060.25.0855.500.11.1503	855	955	755	63	856	854	54	54	9	9	953 -0,23	757 +0,23
2	060.25.0955.500.11.1503	955	1055	855	63	956	954	54	54	9	9	1053 -0,26	857 +0,23
3	060.25.1055.500.11.1503	1055	1155	955	63	1056	1054	54	54	9	9	1153 -0,26	957 +0,23
4	060.25.1155.500.11.1503	1155	1255	1055	63	1156	1154	54	54	9	9	1253 -0,31	1057 +0,26
5	060.25.1255.500.11.1503	1255	1355	1155	63	1256	1254	54	54	9	9	1353 -0,31	1157 +0,26
6	060.25.1355.500.11.1503	1355	1455	1255	63	1356	1354	54	54	9	9	1453 -0,31	1257 +0,26
7	060.25.1455.500.11.1503	1455	1555	1355	63	1456	1454	54	54	9	9	1553 -0,31	1357 +0,26

If centring spigots are required on the indicated diameters D_a^* or D_i^* these must be specified when the order is placed.

*Tolerance data applies in each case to H_r , H_A

Centering height

$H_i = 10$ mm

$H_A = 10$ mm

Centering height
of the companion
structure

max. 9 mm

Static boundary load curves

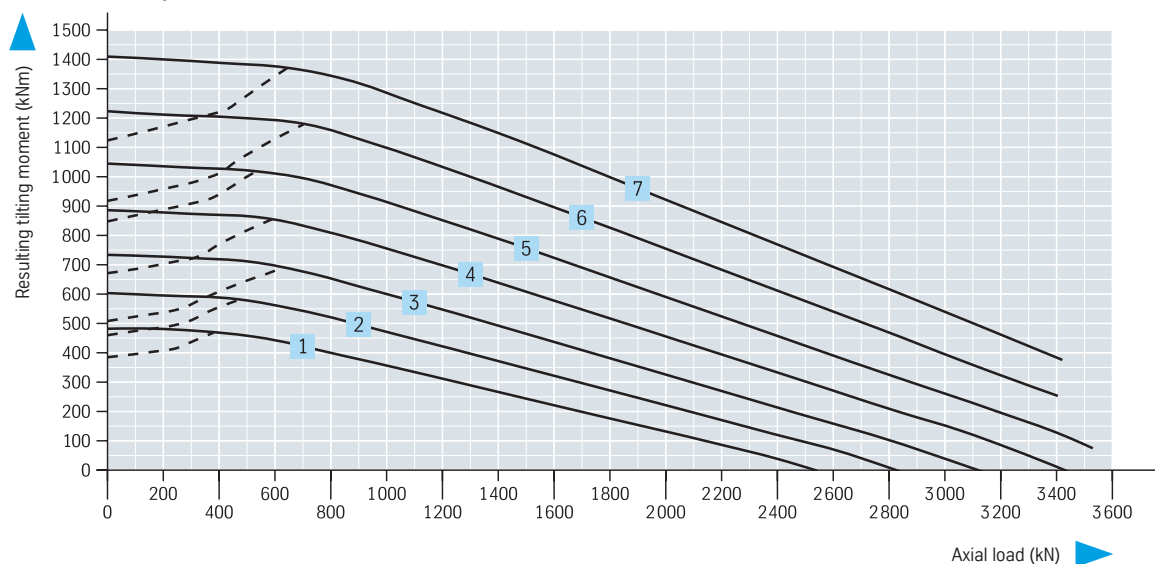

Attachment					Miscellaneous			
$\varnothing L_a$ mm	$\varnothing L_i$ mm	n	$\varnothing B$ mm	M mm	 kg	n_1	Y axial mm	Y radial mm
915	795	28	22	20	100	4	≤ 0,30	≤ 0,25
1015	895	30	22	20	113	6	≤ 0,30	≤ 0,25
1115	995	30	22	20	124	6	≤ 0,30	≤ 0,25
1215	1095	36	22	20	139	6	≤ 0,30	≤ 0,25
1315	1195	42	22	20	148	6	≤ 0,36	≤ 0,30
1415	1295	42	22	20	161	6	≤ 0,36	≤ 0,30
1515	1395	48	22	20	171	6	≤ 0,36	≤ 0,30

► n_1 = Tapered grease nipple
AM 10 x 1 DIN 71412
countersunk and
evenly distributed

Diameter tolerances

Machined diameters with untoleranced
drawing dimensions have the following
tolerances:

- ≤ 1000 mm ± 2,5 mm
- ≤ 2000 mm ± 3,5 mm

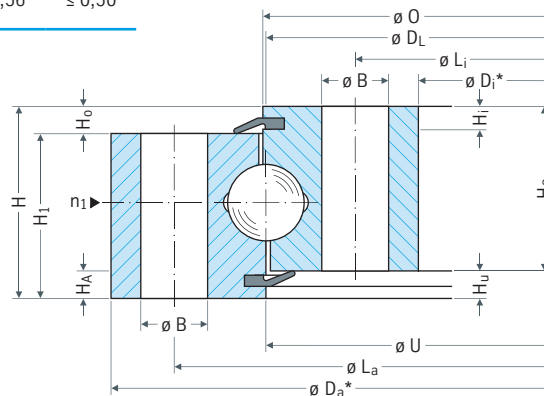

Bearing
selection series
06

Utilization period curves – 30 000 revolutions

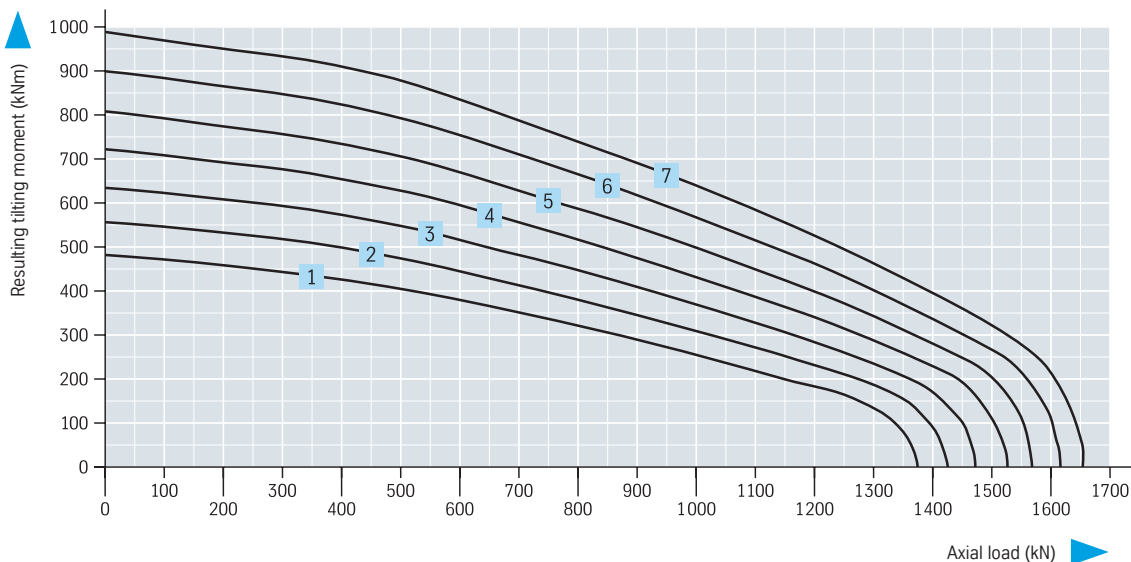

Series 06 Single-row four-point bearing

Standard Series type 625, Normal bearing

Bearing with external gearing		Geometry											
		$\emptyset D_L$ mm	$\emptyset D_a$ mm	$\emptyset D_i$ mm	H mm	$\emptyset O$ mm	$\emptyset U$ mm	H_1 mm	H_2 mm	H_u mm	H_o mm	$\emptyset D_i^*$ mm	$\emptyset U^*$ mm
1	061.25.0855.500.11.1503	855	997,2	755	80	856	854	71	54	26	9	757 +0,23	855 +0,23
2	061.25.0955.500.11.1503	955	1096,2	855	80	956	954	71	54	26	9	857 +0,23	955 +0,23
3	061.25.1055.500.11.1503	1055	1198	955	80	1056	1054	71	54	26	9	957 +0,23	1055 +0,26
4	061.25.1155.500.11.1503	1155	1298	1055	80	1156	1154	71	54	26	9	1057 +0,26	1155 +0,26
5	061.25.1255.500.11.1503	1255	1398	1155	80	1256	1254	71	54	26	9	1157 +0,26	1255 +0,31
6	061.25.1355.500.11.1503	1355	1498	1255	80	1356	1354	71	54	26	9	1257 +0,26	1355 +0,31
7	061.25.1455.500.11.1503	1455	1598	1355	80	1456	1454	71	54	26	9	1357 +0,26	1455 +0,31

If centring spigots are required on the indicated diameters D_a^* or D_i^* these must be specified when the order is placed.

*Tolerance data applies in each case to H_r , H_A

Centering height

$H_i = 10$ mm

$H_z = 10$ mm

Centering height
of the companion
structure

max. 9 mm

Static boundary load curves

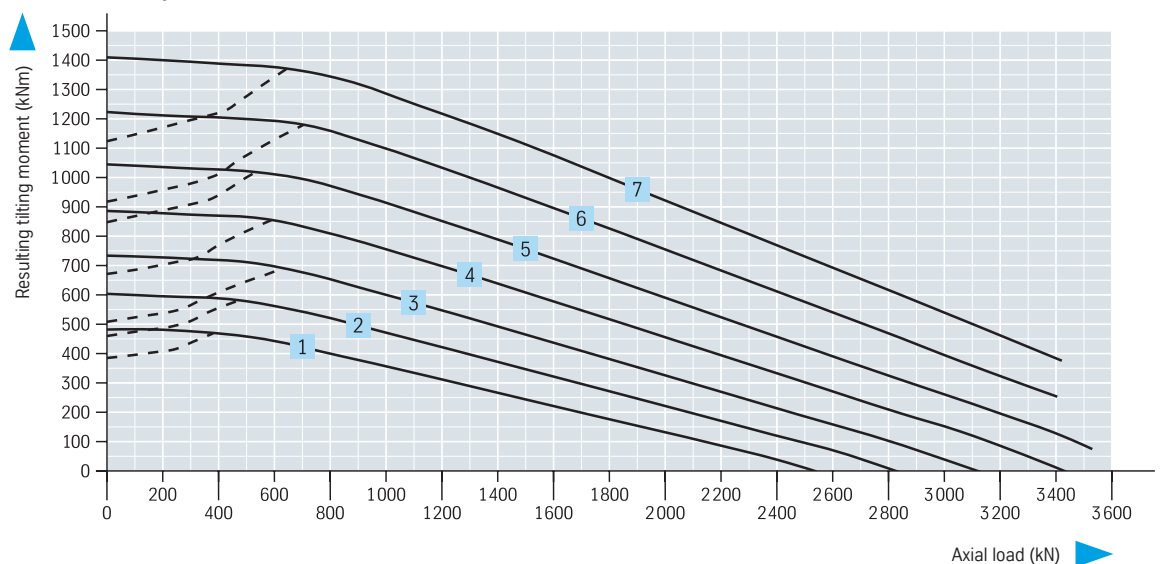

Attachment						Gearing							Miscellaneous			
$\varnothing L_a$ mm	$\varnothing L_i$ mm	n	$\varnothing B$ mm	M mm	t mm	d mm	m mm	z	k · m mm	b_{min} mm	X1 kN	X2 kN	 kg	n_1	Y axial mm	Y radial mm
916	795	28	22	20	40	981	9	109	-0,9	70	32,76	65,52	141	4	≤ 0,30	≤ 0,25
1016	895	30	22	20	40	1080	9	120	-0,9	70	32,76	65,52	158	6	≤ 0,30	≤ 0,25
1116	995	30	22	20	40	1180	10	118	-1,0	70	36,40	72,80	172	6	≤ 0,30	≤ 0,25
1216	1095	36	22	20	40	1280	10	128	-1,0	70	36,40	72,80	190	6	≤ 0,30	≤ 0,25
1316	1195	42	22	20	40	1380	10	138	-1,0	70	36,40	72,80	204	6	≤ 0,36	≤ 0,30
1416	1295	42	22	20	40	1480	10	148	-1,0	70	36,40	72,80	222	6	≤ 0,36	≤ 0,30
1516	1395	48	22	20	40	1580	10	158	-1,0	70	36,40	72,80	236	6	≤ 0,36	≤ 0,30

► n_1 = Tapered grease nipple
AM 10 x 1 DIN 71412
countersunk and
evenly distributed

Diameter tolerances

Machined diameters with untoleranced
drawing dimensions have the following
tolerances:

- ≤ 1000 mm ± 2,5 mm
- ≤ 2000 mm ± 3,5 mm

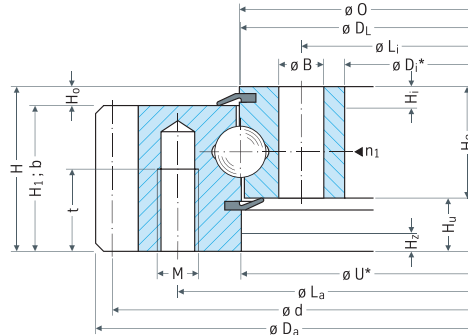

Bearing
selection series
06

Utilization period curves – 30 000 revolutions

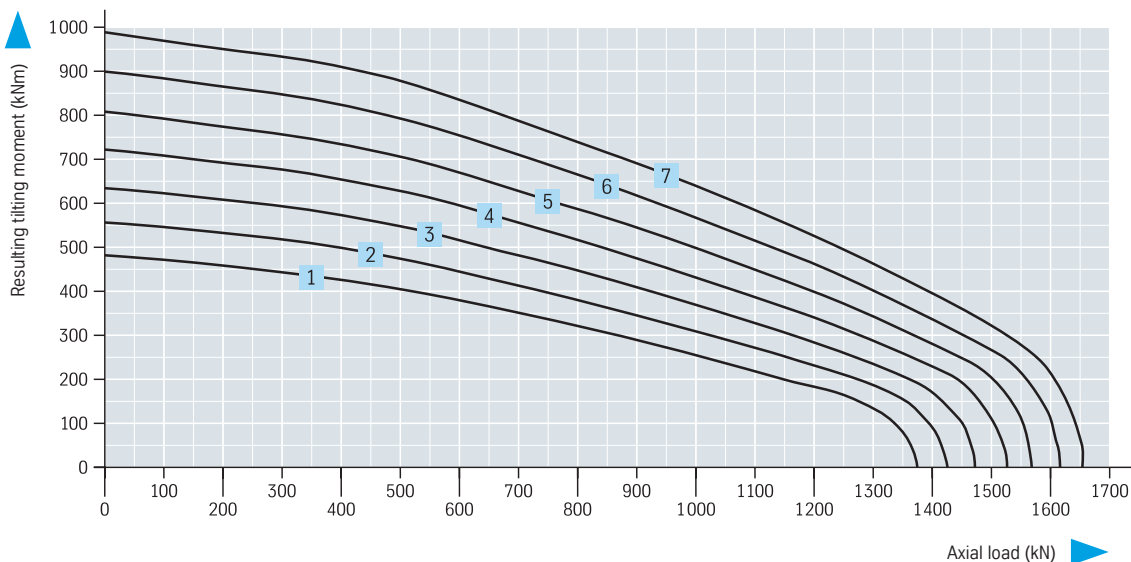

Series 06 Single-row four-point bearing

Standard Series type 625, Normal bearing

Bearing with internal gearing		Geometry											
Drawing number		$\varnothing D_L$ mm	$\varnothing D_a$ mm	$\varnothing D_i$ mm	H mm	$\varnothing O$ mm	$\varnothing U$ mm	H ₁ mm	H ₂ mm	H _u mm	H _o mm	$\varnothing D_a^*$ mm	$\varnothing U^*$ mm
1	062.25.0855.500.11.1503	855	955	710	80	854	856	71	54	26	9	9	9
2	062.25.0955.500.11.1503	955	1055	810	80	954	956	71	54	26	9	9	9
3	062.25.1055.500.11.1503	1055	1155	910	80	1054	1056	71	54	26	9	9	9
4	062.25.1155.500.11.1503	1155	1255	1010	80	1154	1156	71	54	26	9	9	9
5	062.25.1255.500.11.1503	1255	1355	1110	80	1254	1256	71	54	26	9	9	9
6	062.25.1355.500.11.1503	1355	1455	1210	80	1354	1356	71	54	26	9	9	9
7	062.25.1455.500.11.1503	1455	1555	1310	80	1454	1456	71	54	26	9	9	9

If centring spigots are required on the indicated diameters D_a^* or D_i^* these must be specified when the order is placed.

*Tolerance data applies in each case to H_r , H_A

Centering height
 $H_z = 10$ mm
 $H_A = 10$ mm

Centering height of the companion structure
 max. 9 mm

Static boundary load curves

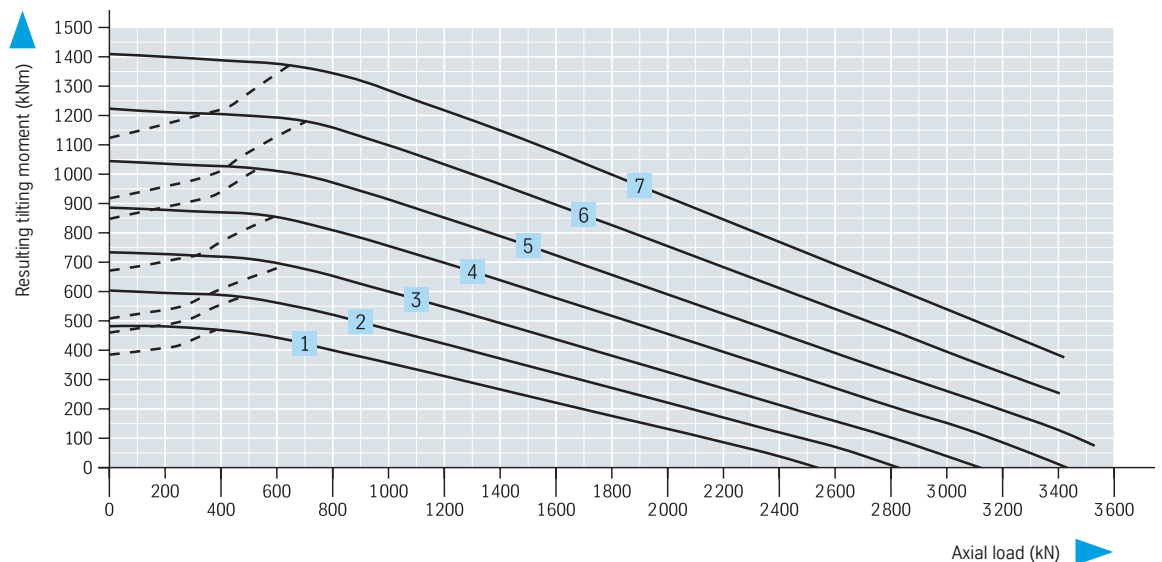

Attachment						Gearing						Miscellaneous			
$\varnothing L_a$ mm	$\varnothing L_l$ mm	n	$\varnothing B$ mm	M mm	t mm	d mm	m mm	z	b_{min} mm	X1 kN	X2 kN	 kg	n_1	Y axial mm	Y radial mm
953 -0,23	855 -0,23	28	22	20	40	730	10	73	70	41,23	82,46	133	4	≤ 0,30	≤ 0,25
1053 -0,26	955 -0,23	30	22	20	40	830	10	83	70	40,60	81,20	150	6	≤ 0,30	≤ 0,25
1153 -0,26	1055 -0,26	30	22	20	40	930	10	93	70	40,06	80,12	166	6	≤ 0,30	≤ 0,25
1253 -0,31	1155 -0,26	36	22	20	40	1030	10	103	70	39,58	79,16	183	6	≤ 0,30	≤ 0,25
1353 -0,31	1255 -0,31	42	22	20	40	1130	10	113	70	39,18	78,36	198	6	≤ 0,36	≤ 0,30
1453 -0,31	1355 -0,31	42	22	20	40	1230	10	123	70	38,83	77,66	215	6	≤ 0,36	≤ 0,30
1553 -0,31	1455 -0,31	48	22	20	40	1330	10	133	70	38,55	77,10	229	6	≤ 0,36	≤ 0,30

► n_1 = Tapered grease nipple
AM 10 x 1 DIN 71412
countersunk and
evenly distributed

Diameter tolerances

Machined diameters with untoleranced
drawing dimensions have the following
tolerances:

- ≤ 1000 mm ± 2,5 mm
- ≤ 2000 mm ± 3,5 mm

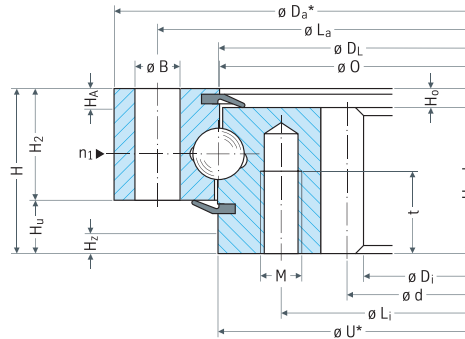

Bearing
selection series
06

Utilization period curves – 30 000 revolutions

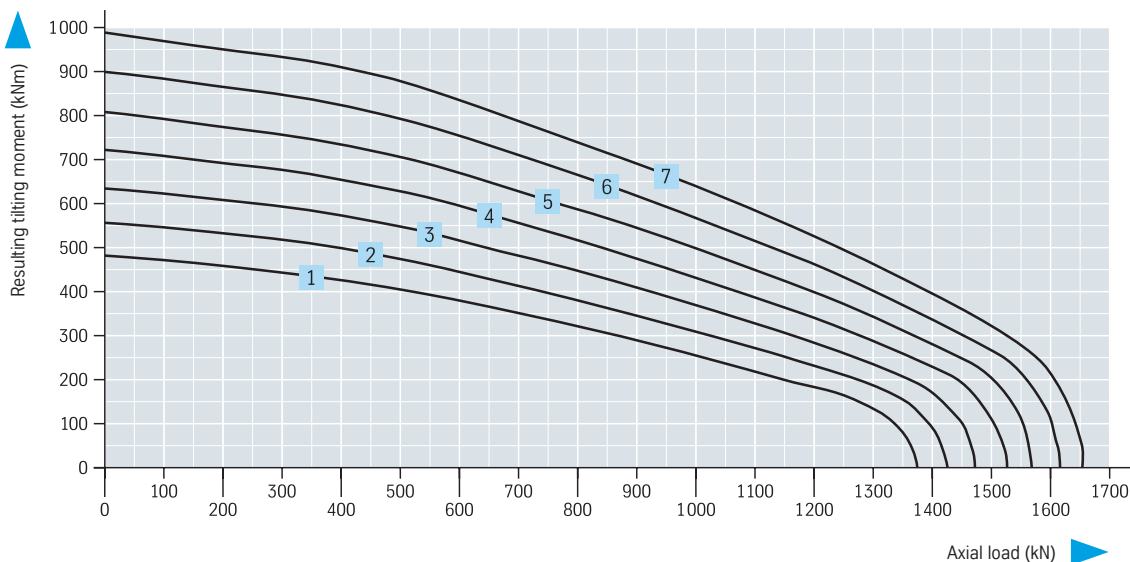

Series 06 Single-row four-point bearing

Standard Series type 625, Bearing with restricted play

Bearing without gearing		Geometry									
Drawing number		$\varnothing D_L$ mm	$\varnothing D_a$ mm	$\varnothing D_i$ mm	H mm	$\varnothing O$ mm	$\varnothing U$ mm	H_1 mm	H_2 mm	H_u mm	H_o mm
1	060.25.0855.575.11.1403	855	953 -0,14	757 +0,14	63	856	854	54	54	9	9
2	060.25.0955.575.11.1403	955	1053 -0,17	857 +0,14	63	956	954	54	54	9	9
3	060.25.1055.575.11.1403	1055	1153 -0,17	957 +0,14	63	1056	1054	54	54	9	9
4	060.25.1155.575.11.1403	1155	1253 -0,20	1057 +0,17	63	1156	1154	54	54	9	9
5	060.25.1255.575.11.1403	1255	1353 -0,20	1157 +0,17	63	1256	1254	54	54	9	9
6	060.25.1355.575.11.1403	1355	1453 -0,20	1257 +0,20	63	1356	1354	54	54	9	9
7	060.25.1455.575.11.1403	1455	1553 -0,20	1357 +0,20	63	1456	1454	54	54	9	9

* Tolerance data applies in each case to H_v, H_A

Centering height
 $H_i = 10$ mm
 $H_A = 10$ mm

Centering height of the companion structure
max. 9 mm

Static boundary load curves

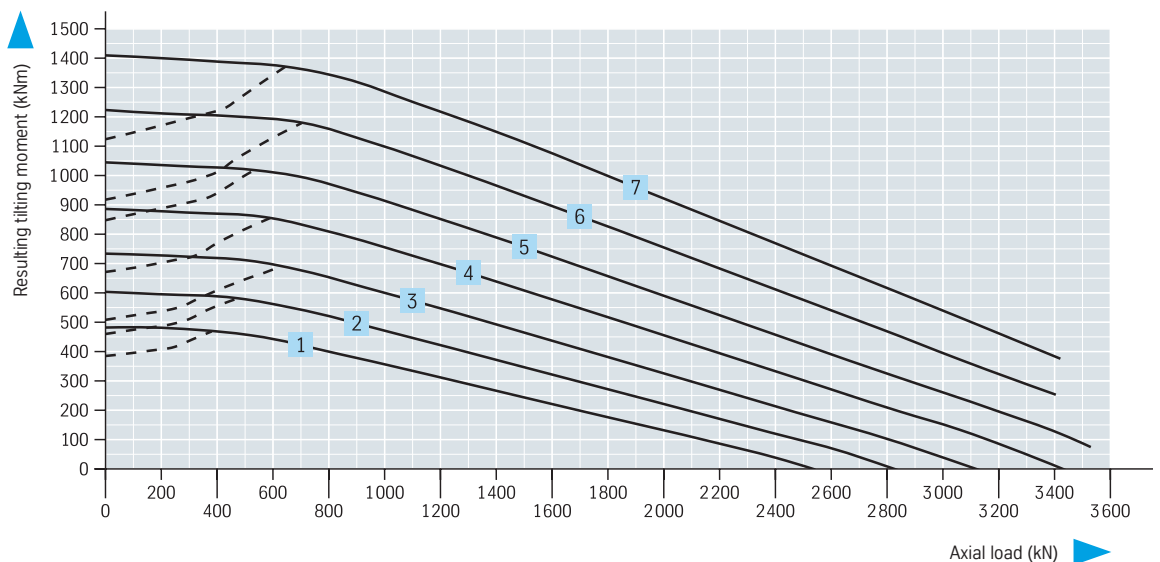

Attachment					Miscellaneous		
$\varnothing L_a$ mm	$\varnothing L_i$ mm	n	$\varnothing B$ mm	M mm	 kg	n_1	Y axial + radial mm
915	795	28	22	20	100	4	≥ 0 to 0,06
1015	895	30	22	20	113	6	≥ 0 to 0,06
1115	995	30	22	20	124	6	≥ 0 to 0,06
1215	1095	36	22	20	139	6	≥ 0 to 0,06
1315	1195	42	22	20	148	6	≥ 0 to 0,07
1415	1295	42	22	20	161	6	≥ 0 to 0,07
1515	1395	48	22	20	171	6	≥ 0 to 0,07

► n_1 = Tapered grease nipple
AM 10 x 1 DIN 71412
countersunk and
evenly distributed

Diameter tolerances

Machined diameters with untoleranced
drawing dimensions have the following
tolerances:

- ≤ 1000 mm ± 2,5 mm
- ≤ 2000 mm ± 3,5 mm

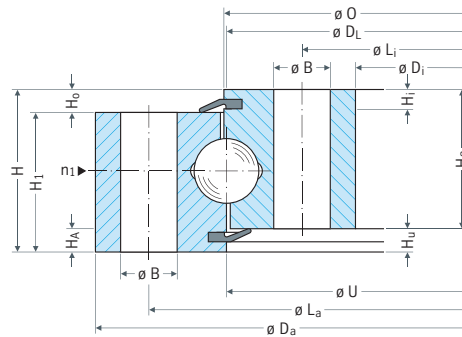

Bearing
selection series
06

Utilization period curves – 30 000 revolutions

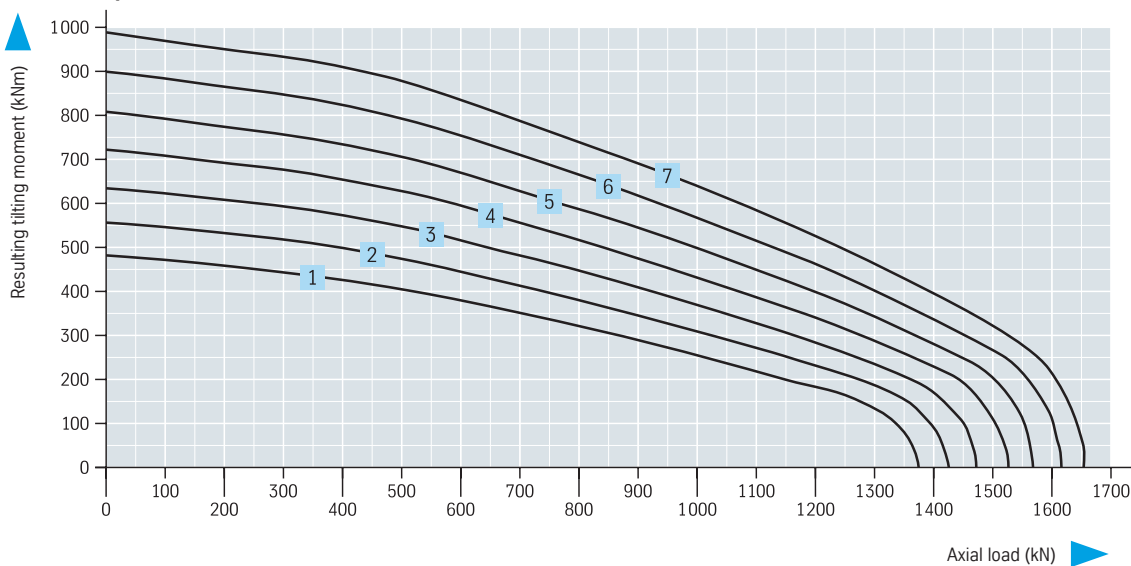

Series 06 Single-row four-point bearing

Standard Series type 625, Bearing with restricted play

Bearing with external gearing		Geometry									
Drawing number		$\varnothing D_L$ mm	$\varnothing D_a$ mm	$\varnothing D_i$ mm	H mm	$\varnothing O$ mm	$\varnothing U$ mm	H ₁ mm	H ₂ mm	H _u mm	H _o mm
1	061.25.0855.575.11.1403	855	997,2	757 +0,14	80	856	855 +0,14	71	54	26	9
2	061.25.0955.575.11.1403	955	1096,2	857 +0,14	80	956	955 +0,14	71	54	26	9
3	061.25.1055.575.11.1403	1055	1198,0	957 +0,14	80	1056	1055 +0,17	71	54	26	9
4	061.25.1155.575.11.1403	1155	1298,0	1057 +0,17	80	1156	1155 +0,17	71	54	26	9
5	061.25.1255.575.11.1403	1255	1398,0	1157 +0,17	80	1256	1255 +0,20	71	54	26	9
6	061.25.1355.575.11.1403	1355	1498,0	1257 +0,20	80	1356	1355 +0,20	71	54	26	9
7	061.25.1455.575.11.1403	1455	1598,0	1357 +0,20	80	1456	1455 +0,20	71	54	26	9

* Tolerance data
applies in each case to
H_v, H_z

Centering height
H_i = 10 mm
H_z = 10 mm

Centering height
of the companion
structure
max. 9 mm

Static boundary load curves

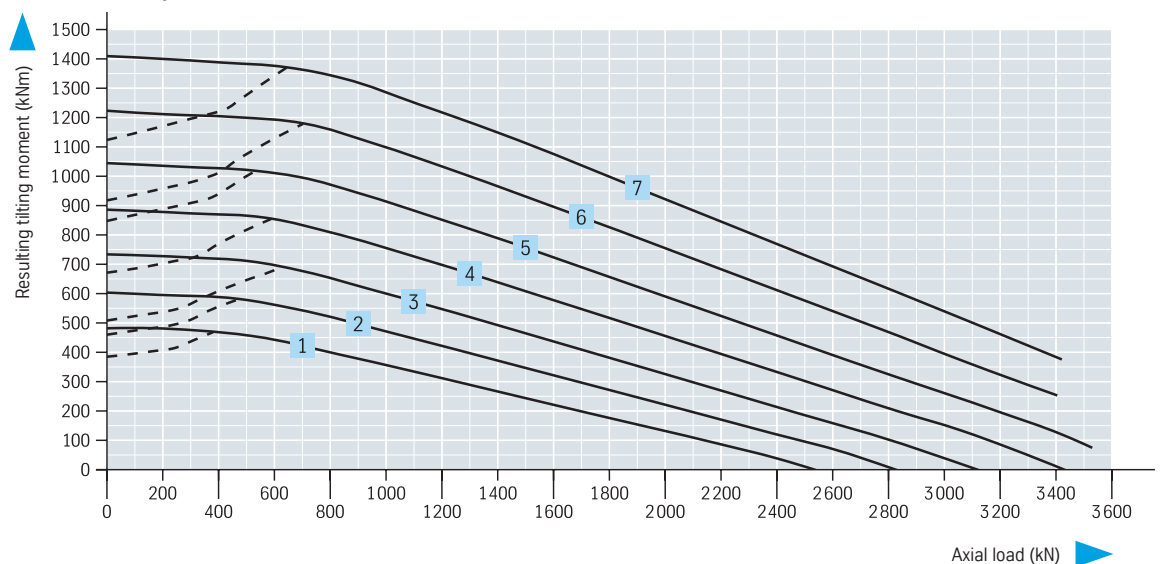

Attachment						Gearing							Miscellaneous		
$\emptyset L_a$ mm	$\emptyset L_i$ mm	n	$\emptyset B$ mm	M mm	t mm	d mm	m mm	z	k · m mm	b_{min} mm	X1 kN	X2 kN	 kg	n_1	Y axial + radial mm
916	795	28	22	20	40	981	9	109	-0,9	70	32,76	65,52	141	4	≥ 0 to 0,06
1016	895	30	22	20	40	1080	9	120	-0,9	70	32,76	65,52	158	6	≥ 0 to 0,06
1116	995	30	22	20	40	1180	10	118	-1,0	70	36,40	72,80	172	6	≥ 0 to 0,06
1216	1095	36	22	20	40	1280	10	128	-1,0	70	36,40	72,80	190	6	≥ 0 to 0,06
1316	1195	42	22	20	40	1380	10	138	-1,0	70	36,40	72,80	204	6	≥ 0 to 0,07
1416	1295	42	22	20	40	1480	10	148	-1,0	70	36,40	72,80	222	6	≥ 0 to 0,07
1516	1395	48	22	20	40	1580	10	158	-1,0	70	36,40	72,80	236	6	≥ 0 to 0,07

► n_1 = Tapered grease nipple
AM 10 x 1 DIN 71412
countersunk and
evenly distributed

Diameter tolerances

Machined diameters with untoleranced
drawing dimensions have the following
tolerances:

- ≤ 1000 mm ± 2,5 mm
- ≤ 2000 mm ± 3,5 mm

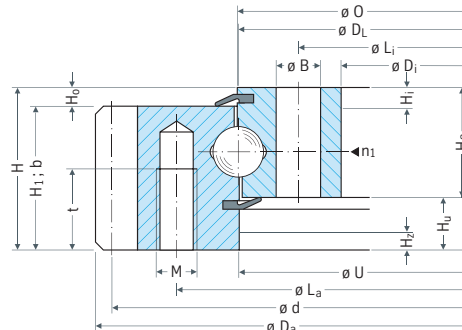

Bearing
selection series
06

Utilization period curves – 30 000 revolutions

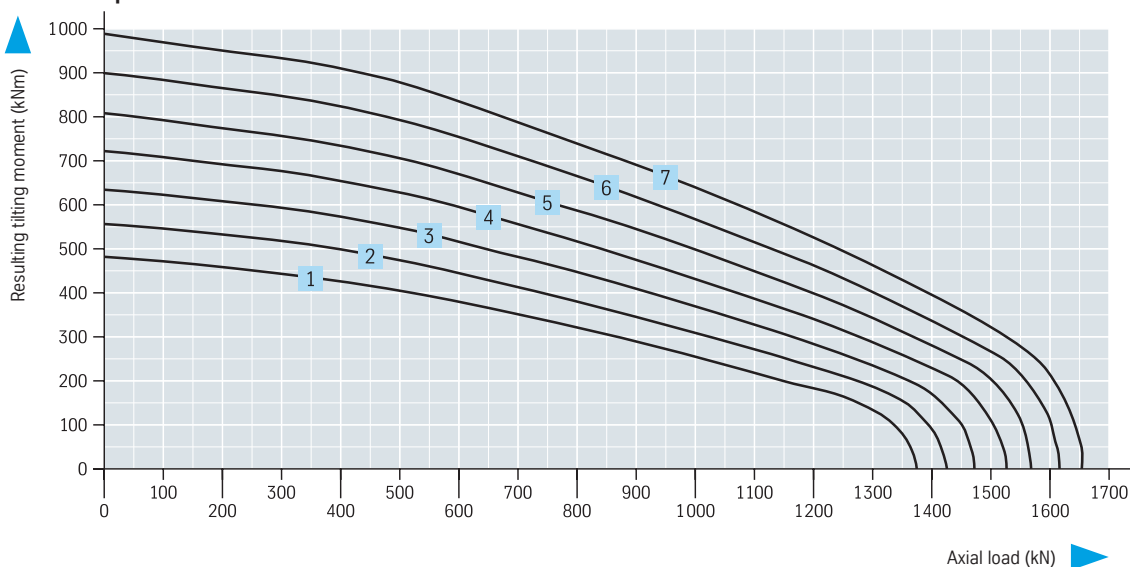

Series 06 Single-row four-point bearing

Standard Series type 625, Bearing with restricted play

Bearing with internal gearing		Geometry									
Drawing number		$\varnothing D_L$ mm	$\varnothing D_a$ mm	$\varnothing D_i$ mm	H mm	$\varnothing O$ mm	$\varnothing U$ mm	H ₁ mm	H ₂ mm	H _u mm	H _o mm
1	062.25.0855.575.11.1403	855	$\begin{matrix} 953 \\ -0,14 \end{matrix}$	710	80	854	$\begin{matrix} 855 \\ -0,14 \end{matrix}$	71	54	26	9
2	062.25.0955.575.11.1403	955	$\begin{matrix} 1053 \\ -0,17 \end{matrix}$	810	80	954	$\begin{matrix} 955 \\ -0,14 \end{matrix}$	71	54	26	9
3	062.25.1055.575.11.1403	1055	$\begin{matrix} 1153 \\ -0,17 \end{matrix}$	910	80	1054	$\begin{matrix} 1055 \\ -0,17 \end{matrix}$	71	54	26	9
4	062.25.1155.575.11.1403	1155	$\begin{matrix} 1253 \\ -0,20 \end{matrix}$	1010	80	1154	$\begin{matrix} 1155 \\ -0,17 \end{matrix}$	71	54	26	9
5	062.25.1255.575.11.1403	1255	$\begin{matrix} 1353 \\ -0,20 \end{matrix}$	1110	80	1254	$\begin{matrix} 1255 \\ -0,20 \end{matrix}$	71	54	26	9
6	062.25.1355.575.11.1403	1355	$\begin{matrix} 1453 \\ -0,20 \end{matrix}$	1210	80	1354	$\begin{matrix} 1355 \\ -0,20 \end{matrix}$	71	54	26	9
7	062.25.1455.575.11.1403	1455	$\begin{matrix} 1553 \\ -0,20 \end{matrix}$	1310	80	1454	$\begin{matrix} 1455 \\ -0,20 \end{matrix}$	71	54	26	9

* Tolerance data applies in each case to H_A, H_Z

Centering height
H_Z = 10 mm
H_A = 10 mm

Centering height of the companion structure
max. 9 mm

Static boundary load curves

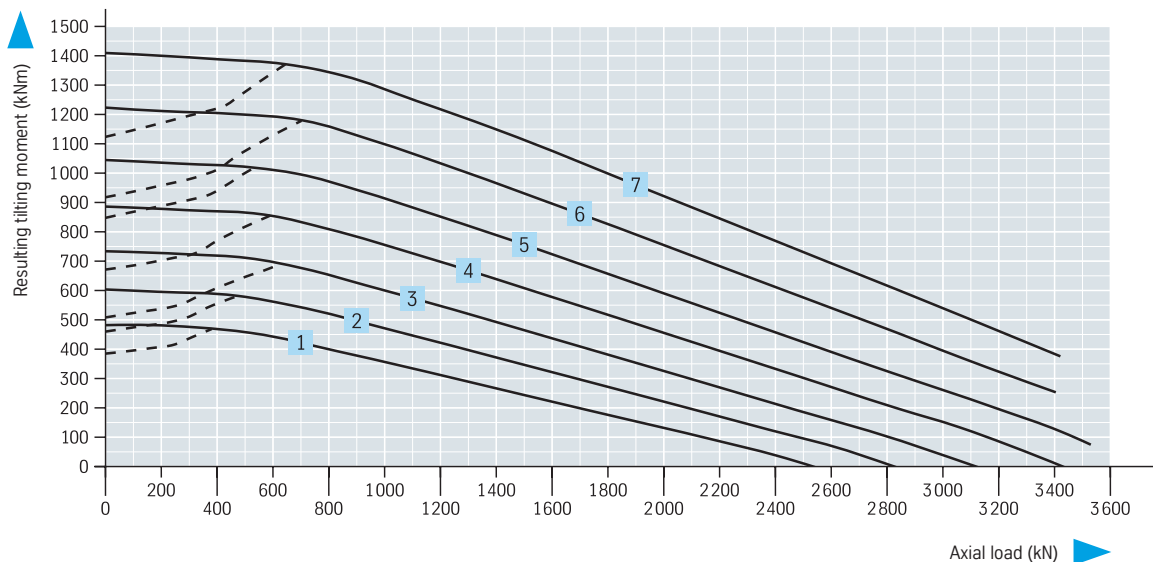

Attachment						Gearing						Miscellaneous		
$\emptyset L_a$ mm	$\emptyset L_i$ mm	n	$\emptyset B$ mm	M mm	t mm	d mm	m mm	z	b_{min} mm	X1 kN	X2 kN	 kg	n_1	Y axial + radial mm
915	794	28	22	20	40	730	10	73	70	41,23	82,46	133	4	≥ 0 to 0,06
1015	894	30	22	20	40	830	10	83	70	40,60	81,20	150	6	≥ 0 to 0,06
1115	994	30	22	20	40	930	10	93	70	40,06	80,12	166	6	≥ 0 to 0,06
1215	1094	36	22	20	40	1030	10	103	70	39,58	79,16	183	6	≥ 0 to 0,06
1315	1194	42	22	20	40	1130	10	113	70	39,18	78,36	198	6	≥ 0 to 0,07
1415	1294	42	22	20	40	1230	10	123	70	38,83	77,66	215	6	≥ 0 to 0,07
1515	1394	48	22	20	40	1330	10	133	70	38,55	77,10	229	6	≥ 0 to 0,07

► n_1 = Tapered grease nipple
AM 10 x 1 DIN 71412
countersunk and
evenly distributed

Diameter tolerances

Machined diameters with untoleranced
drawing dimensions have the following
tolerances:

- ≤ 1000 mm ± 2,5 mm
- ≤ 2000 mm ± 3,5 mm

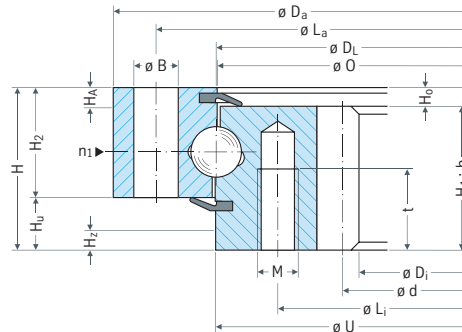

Bearing
selection series
06

Utilization period curves – 30 000 revolutions

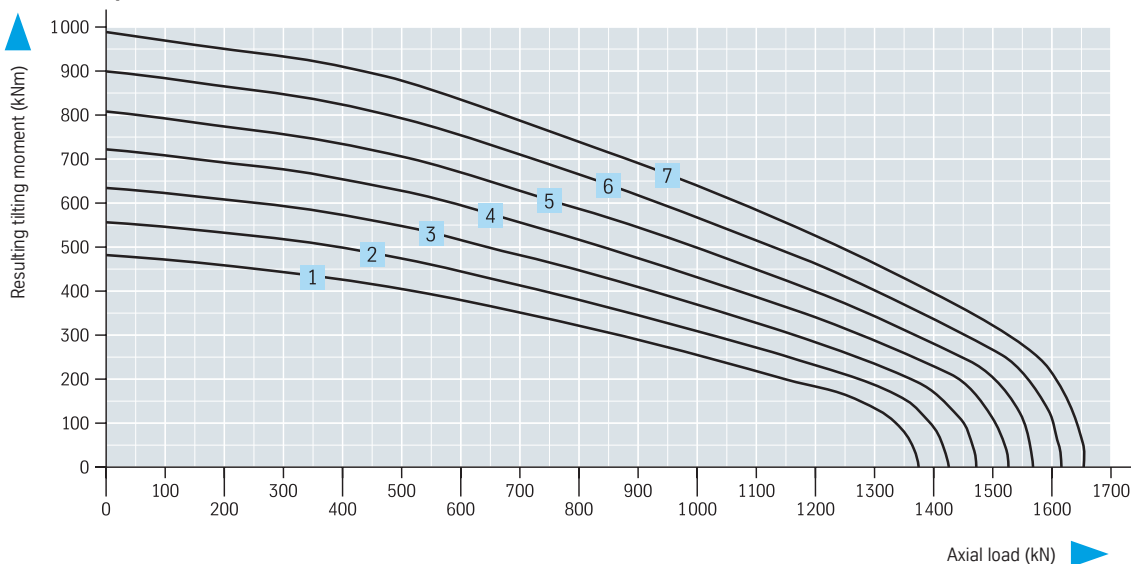

Series 06 Single-row four-point bearing

Bearing with external gearing		Geometry									
Drawing number		$\varnothing D_L$ mm	$\varnothing D_a$ mm	$\varnothing D_i$ mm	H mm	$\varnothing O$ mm	$\varnothing U$ mm	H ₁ mm	H ₂ mm	H _u mm	H _o mm
1	061.25.0764.103.11.1504 061.25.0764.106.21.1504	764	862,8	670	82	765	763	65	61	21	17
2	061.25.0980.107.11.1504 061.25.0980.108.21.1504	980	1078,4	886	79	981	979	67	58	21	12

Ring gear normalised

Ring gear annealed

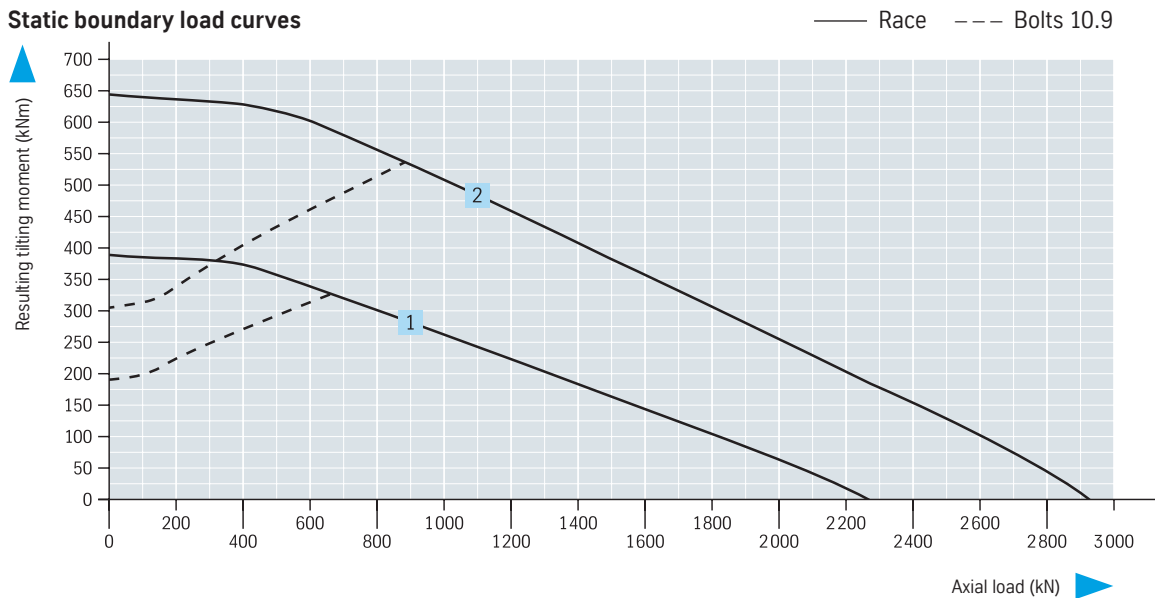

Attachment						Gearing										Miscellaneous	
$\varnothing L_a$ mm	$\varnothing L_i$ mm	n	$\varnothing B$ mm	M mm	t mm	d mm	m mm	z	x · m mm	k · m mm	b mm	$\varnothing Z_u$ mm	$\varnothing h_u$ mm	X1 kN	X2 kN	kg	n_1
800	706	24	17,5	16	24	852	6	142	+0,0	-0,6	56	833	9	17,45 26,88	34,90 53,76	98	4
1015	922	30	17,5	16	24	1064	8	133	+0,0	-0,8	62	1042	5	25,80 39,68	51,60 79,36	123	5

Diameter tolerances

Machined diameters with untoleranced drawing dimensions have the following tolerances:

- ≤ 1000 mm ± 2,5 mm
- ≤ 2000 mm ± 3,5 mm

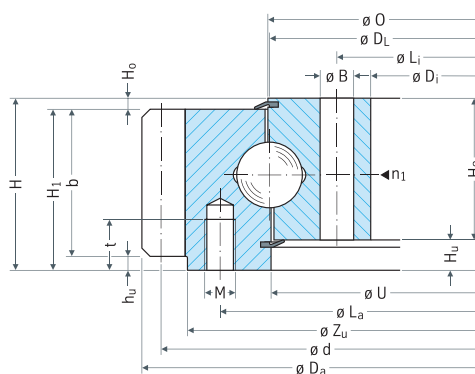

Bearing selection series 06

Utilization period curves – 30 000 revolutions

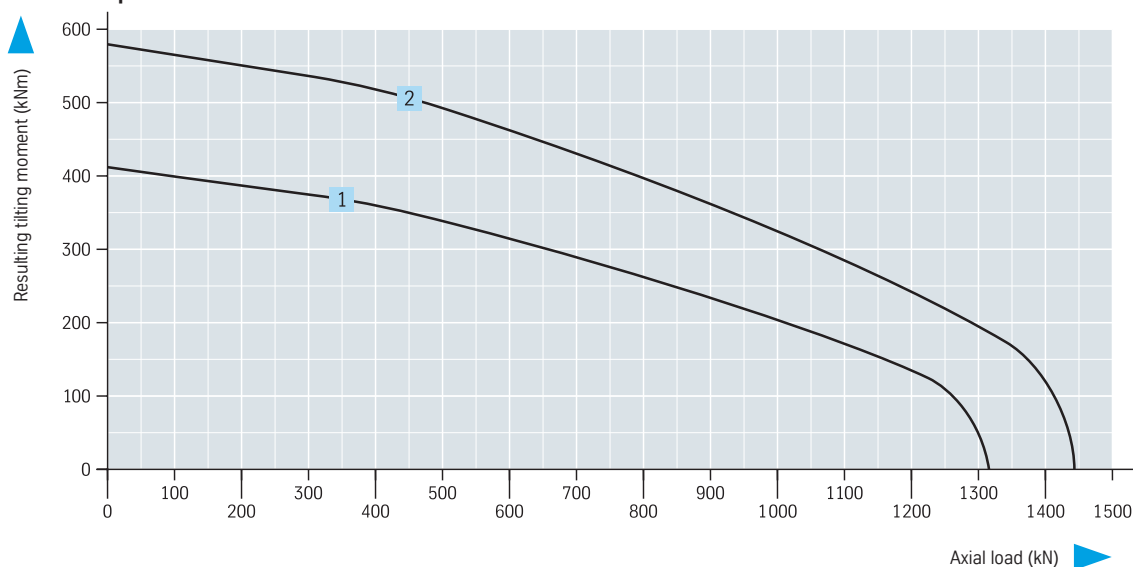

Series 06 Single-row four-point bearing

Bearing with external gearing		Geometry									
Drawing number		$\varnothing D_L$ mm	$\varnothing D_a$ mm	$\varnothing D_i$ mm	H mm	$\varnothing O$ mm	$\varnothing U$ mm	H ₁ mm	H ₂ mm	H _u mm	H _o mm
3	061.20.0400.100.11.1503 061.20.0400.101.21.1503	400	499,8	325	55	401	399	46	46	9	9
4	061.20.0450.100.11.1503 061.20.0450.101.21.1503	450	554,8	369	55	451	449	46	46	9	9
5	061.20.0560.100.11.1503 061.20.0560.101.21.1503	560	670,8	479	55	561	559	46	46	9	9
6	061.20.0630.100.11.1503 061.20.0630.101.21.1503	630	742,8	543	55	631	629	46	46	9	9
7	061.20.0710.100.11.1503 061.20.0710.101.21.1503	710	820,8	623	55	711	709	46	46	9	9

Ring gear normalised
 Ring gear annealed

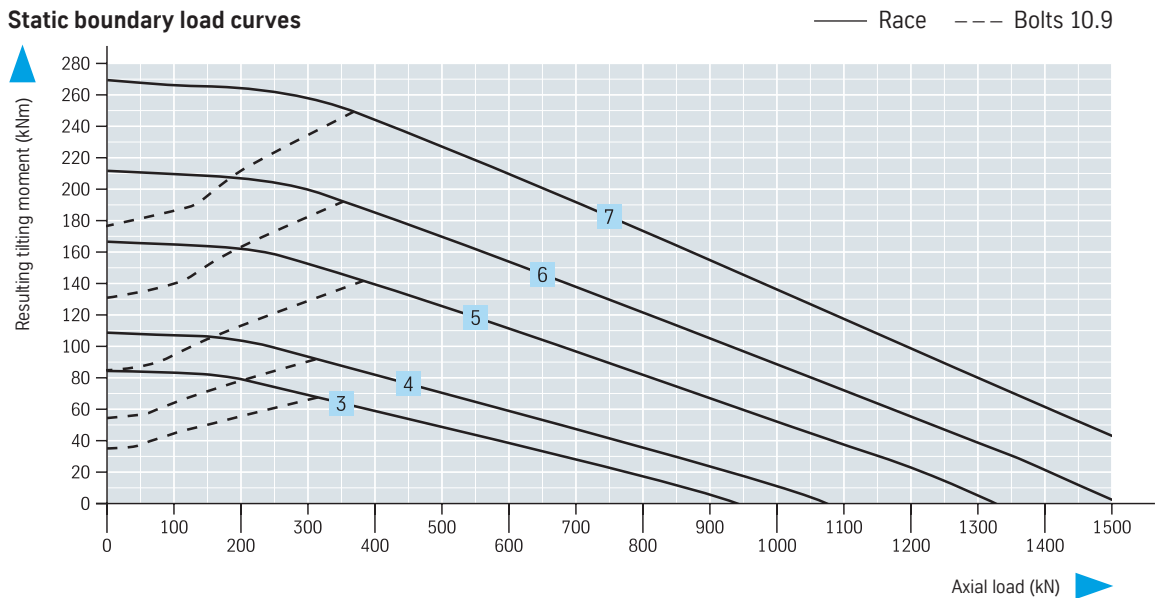

Attachment					Gearing								Miscellaneous	
$\emptyset L_a$ mm	$\emptyset L_i$ mm	n	$\emptyset B$ mm	M mm	d mm	m mm	z	x · m mm	k · m mm	b _{min} mm	X1 kN	X2 kN	kg	n ₁
448	352	16	13,5	12	485	5	97	+ 2,5	- 0,5	45	14,13 21,74	28,26 43,48	35	2
500	400	16	15,5	14	540	5	108	+ 2,5	- 0,5	45	14,13 21,74	28,26 43,48	39	2
610	510	20	15,5	14	654	6	109	+ 3,0	- 0,6	45	16,96 26,09	33,91 52,17	53	4
682	578	20	17,5	16	726	6	121	+ 3,0	- 0,6	45	16,96 26,09	33,91 52,17	61	4
762	658	24	17,5	16	804	6	134	+ 3,0	- 0,6	45	16,96 26,09	33,91 52,17	67	4

Diameter tolerances

Machined diameters with untoleranced drawing dimensions have the following tolerances:

≤ 1000 mm ± 2,5 mm

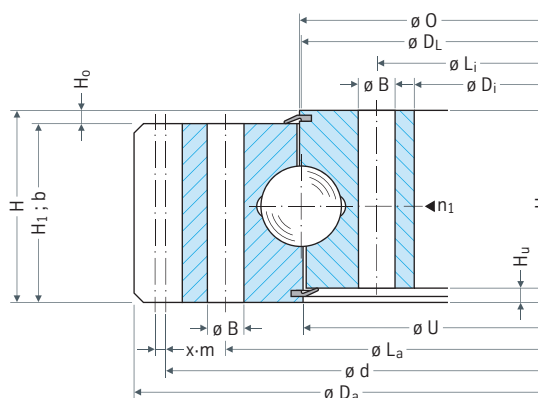

Bearing selection series 06

Utilization period curves – 30 000 revolutions

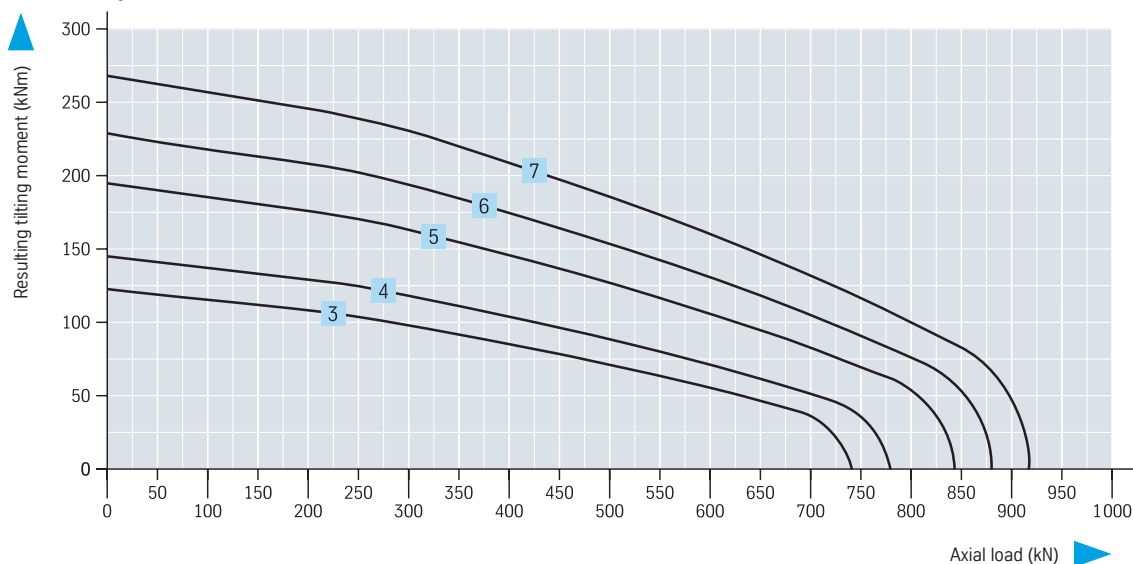

Series 06 Single-row four-point bearing

Bearing with external gearing		Geometry									
Drawing number		$\varnothing D_L$ mm	$\varnothing D_a$ mm	$\varnothing D_i$ mm	H mm	$\varnothing O$ mm	$\varnothing U$ mm	H ₁ mm	H ₂ mm	H _u mm	H _o mm
8	061.25.0764.600.11.1503 061.25.0764.601.21.1503	764	886,8	671	63	765	763	54	54	9	9
9	061.25.0980.890.11.1503 061.25.0980.891.21.1503	980	1110,4	887	63	981	979	54	54	9	9
10	061.25.1120.000.11.1504 061.25.1120.001.21.1504	1120	1278,4	1013	79	1121	1119	70	54	25	9
11	061.25.1250.100.11.1504 061.25.1250.101.21.1504	1250	1408,4	1143	79	1251	1249	70	54	25	9

Ring gear normalised
 Ring gear annealed

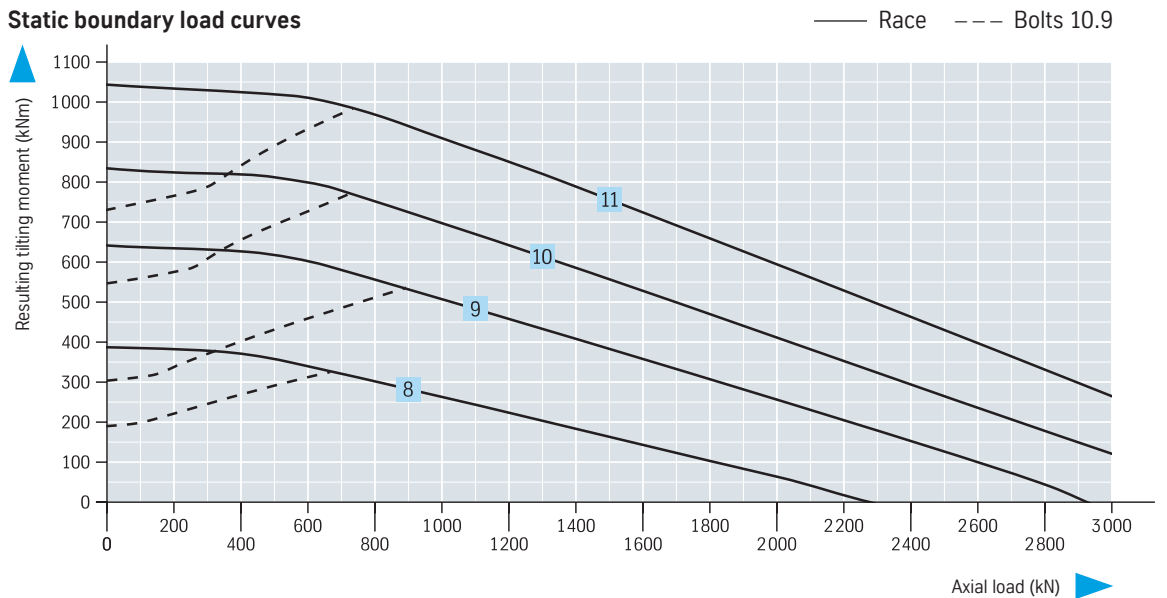

Attachment					Gearing								Miscellaneous	
$\emptyset L_a$ mm	$\emptyset L_i$ mm	n	$\emptyset B$ mm	M mm	d mm	m mm	z	x · m mm	k · m mm	b _{min} mm	X1 kN	X2 kN	kg	n ₁
823	706	24	17,5	16	870	6	145	+ 3,0	- 0,6	53	19,97 30,72	39,94 61,45	95	4
1039	922	30	17,5	16	1088	8	136	+ 4,0	- 0,8	53	26,63 40,97	53,26 81,93	124	5
1183	1057	30	22,0	20	1250	10	125	+ 5,0	- 1,0	69	43,33 66,67	86,67 133,33	182	5
1313	1187	36	22,0	20	1380	10	138	+ 5,0	- 1,0	69	43,33 66,67	86,67 133,33	221	6

Diameter tolerances

Machined diameters with untoleranced drawing dimensions have the following tolerances:

- ≤ 1000 mm ± 2,5 mm
- ≤ 2000 mm ± 3,5 mm

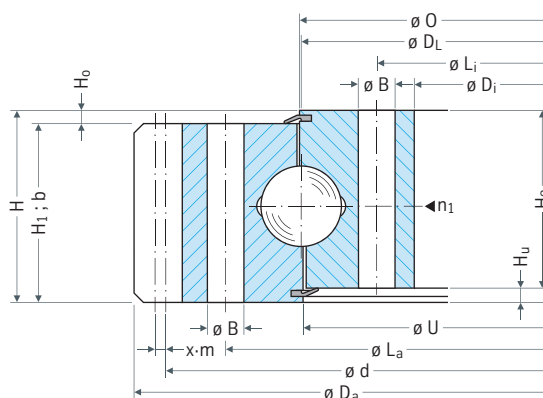

Bearing selection series 06

Utilization period curves – 30 000 revolutions

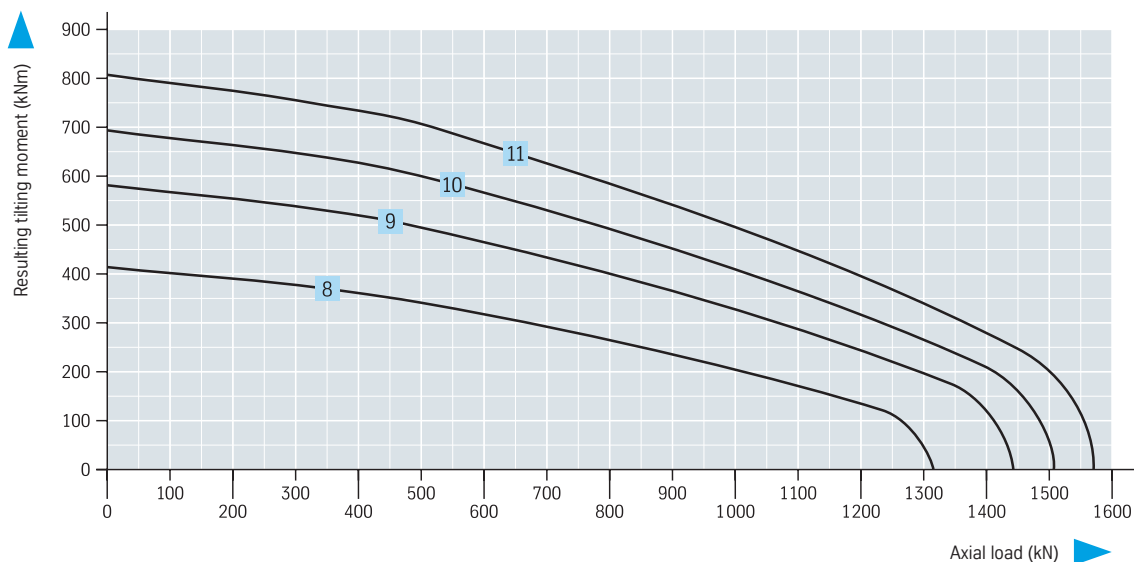

Series 06 Single-row four-point bearing

Bearing with external gearing		Geometry									
Drawing number		$\varnothing D_L$ mm	$\varnothing D_a$ mm	$\varnothing D_i$ mm	H mm	$\varnothing O$ mm	$\varnothing U$ mm	H ₁ mm	H ₂ mm	H _U mm	H _o mm
12	061.30.1180.000.11.1504 061.30.1180.001.21.1504	1180	1338,6	1068	79	1181	1178	70	63	16	9
13	061.30.1320.000.11.1504 061.30.1320.001.21.1504	1320	1497,6	1208	89	1321	1318	80	63	26	9
14	061.30.1500.200.11.1504 061.30.1500.201.21.1523	1500	1677,6	1388	89	1501	1498	80	63	26	9

Ring gear normalised
 Ring gear annealed

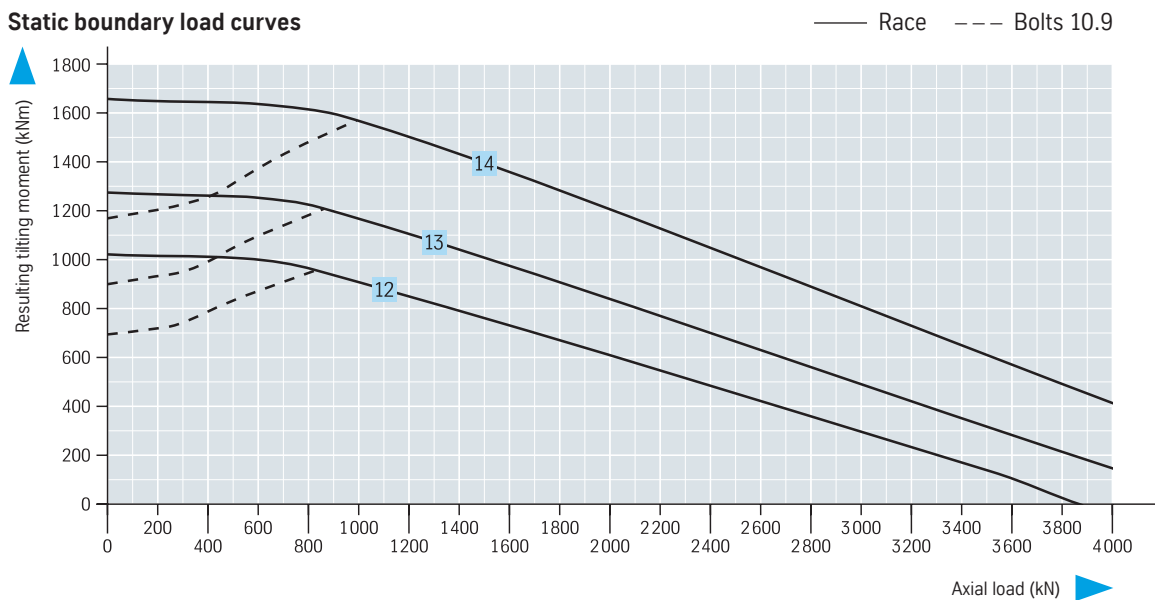

Attachment					Gearing								Miscellaneous	
$\emptyset L_a$ mm	$\emptyset L_i$ mm	n	$\emptyset B$ mm	M mm	d mm	m mm	z	x · m mm	k · m mm	b _{min} mm	X1 kN	X2 kN	kg	n ₁
1248	1112	36	22	20	1310	10	131	+ 5,0	- 1,0	69	43,33 63,33	86,67 126,67	227	6
1388	1252	42	22	20	1464	12	122	+ 6,0	- 1,2	79	59,54 87,01	119,07 174,03	298	6
1568	1432	48	22	20	1644	12	137	+ 6,0	- 1,2	79	59,54 87,01	119,07 174,03	338	6

Diameter tolerances

Machined diameters with untoleranced drawing dimensions have the following tolerances:

≤ 2000 mm ± 3,5 mm

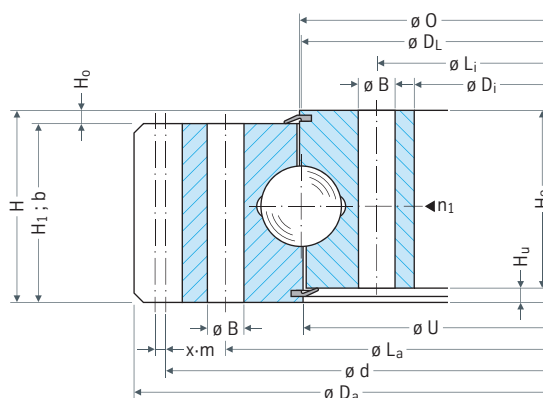

Bearing selection series 06

Utilization period curves – 30 000 revolutions

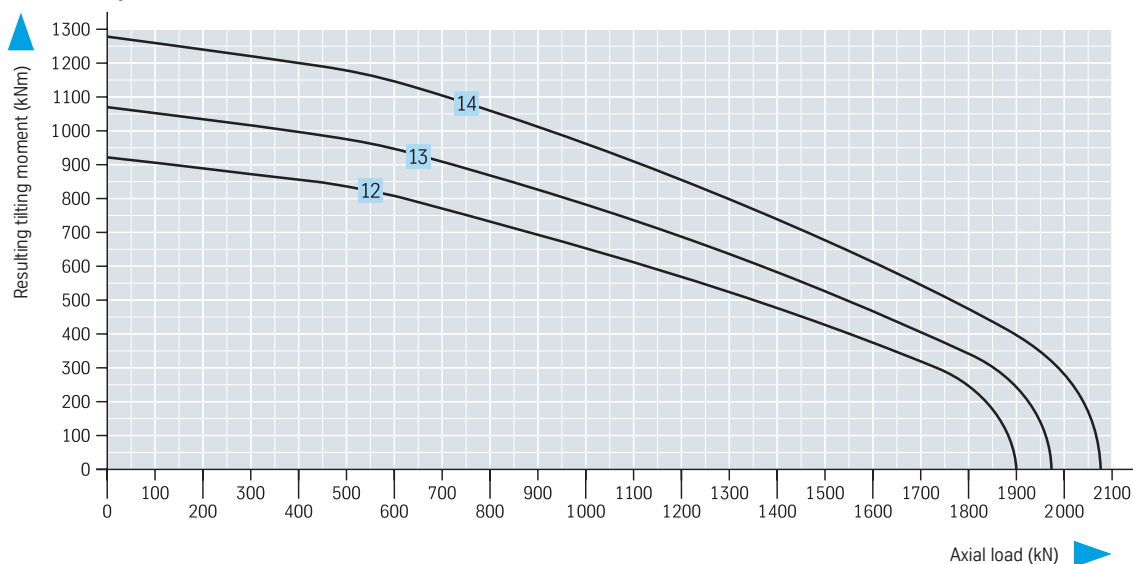

Series 06 Single-row four-point bearing

Bearing with external gearing		Geometry									
Drawing number		$\varnothing D_L$ mm	$\varnothing D_a$ mm	$\varnothing D_i$ mm	H mm	$\varnothing O$ mm	$\varnothing U$ mm	H ₁ mm	H ₂ mm	H _u mm	H _o mm
15	061.40.1400.000.19.1504 061.40.1400.001.29.1504	1400	1593,6	1266	94	1401	1398	85	81	13	9
16	061.40.1600.008.19.1503 061.40.1600.009.29.1503	1600	1803,2	1466	94	1601	1598	85	81	13	9
17	061.40.1800.013.19.1503 061.40.1800.014.29.1503	1800	1999,2	1666	94	1801	1798	85	81	13	9

Ring gear normalised
 Ring gear annealed

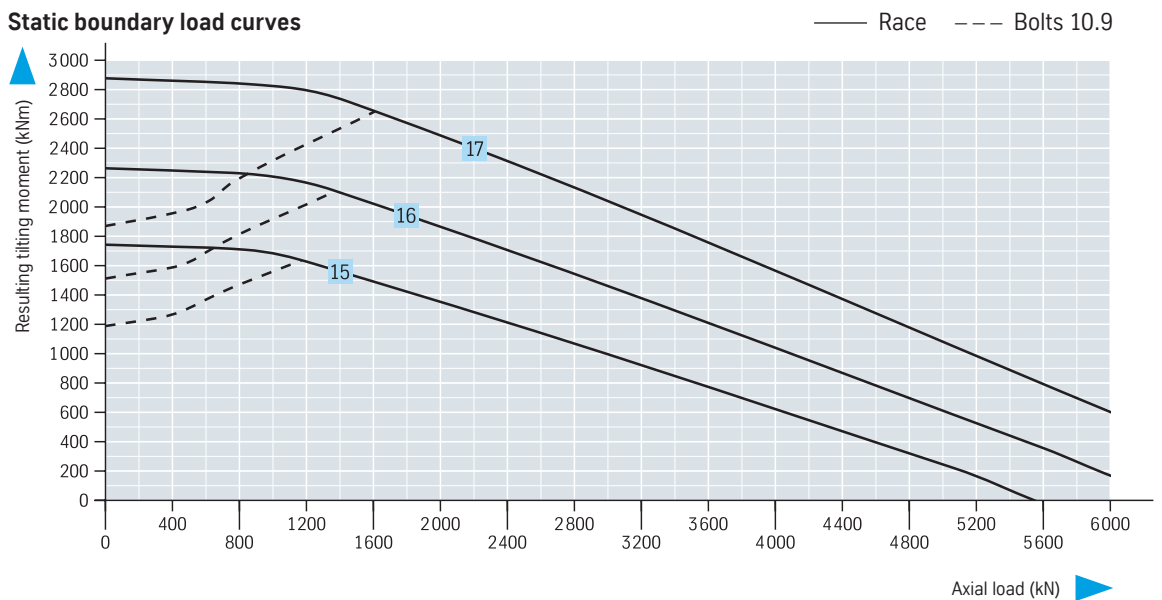

Attachment					Gearing								Miscellaneous	
$\varnothing L_a$ mm	$\varnothing L_i$ mm	n	$\varnothing B$ mm	M mm	d mm	m mm	z	x · m mm	k · m mm	b _{min} mm	X1 kN	X2 kN	kg	n ₁
1482	1318	36	26	24	1560	12	130	+ 6,0	- 1,2	84	63,30 92,52	126,61 185,04	404	6
1682	1518	40	26	24	1764	14	126	+ 7,0	- 1,4	84	73,86 107,94	147,71 215,88	479	8
1882	1718	44	26	24	1960	14	140	+ 7,0	- 1,4	84	73,86 107,94	147,71 215,88	531	11

Diameter tolerances

Machined diameters with untoleranced drawing dimensions have the following tolerances:

≤ 2000 mm ± 3,5 mm

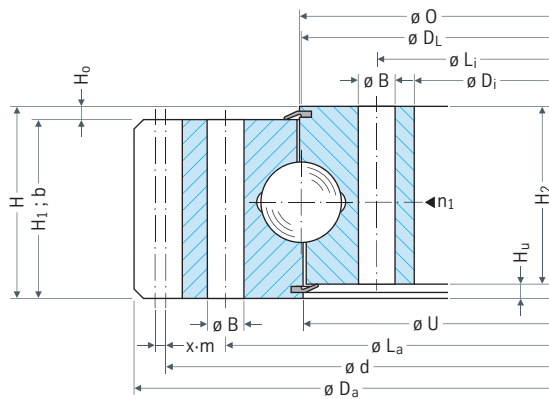

Bearing selection series 06

Utilization period curves – 30 000 revolutions

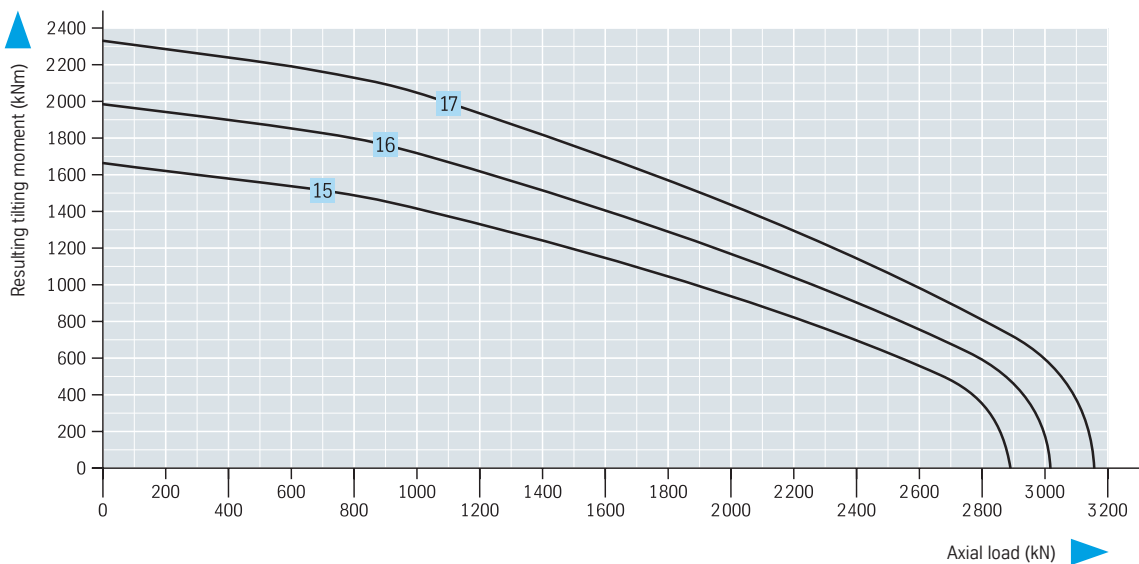

Series 06 Single-row four-point bearing

Bearing with external gearing		Geometry									
Drawing number		$\varnothing D_L$ mm	$\varnothing D_a$ mm	$\varnothing D_i$ mm	H mm	$\varnothing O$ mm	$\varnothing U$ mm	H ₁ mm	H ₂ mm	H _u mm	H _o mm
18	061.50.1900.001.49.1504	1900	2139,2	1729	109	1902	1898	100	99	10	9
19	061.50.2130.001.49.1504	2130	2380,8	1959	109	2132	2128	100	99	10	9
20	061.50.2355.001.49.1504	2355	2604,8	2184	109	2357	2353	100	99	10	9
21	061.50.2645.001.49.1504	2645	2892,8	2474	109	2647	2643	100	99	10	9

Ring gear annealed

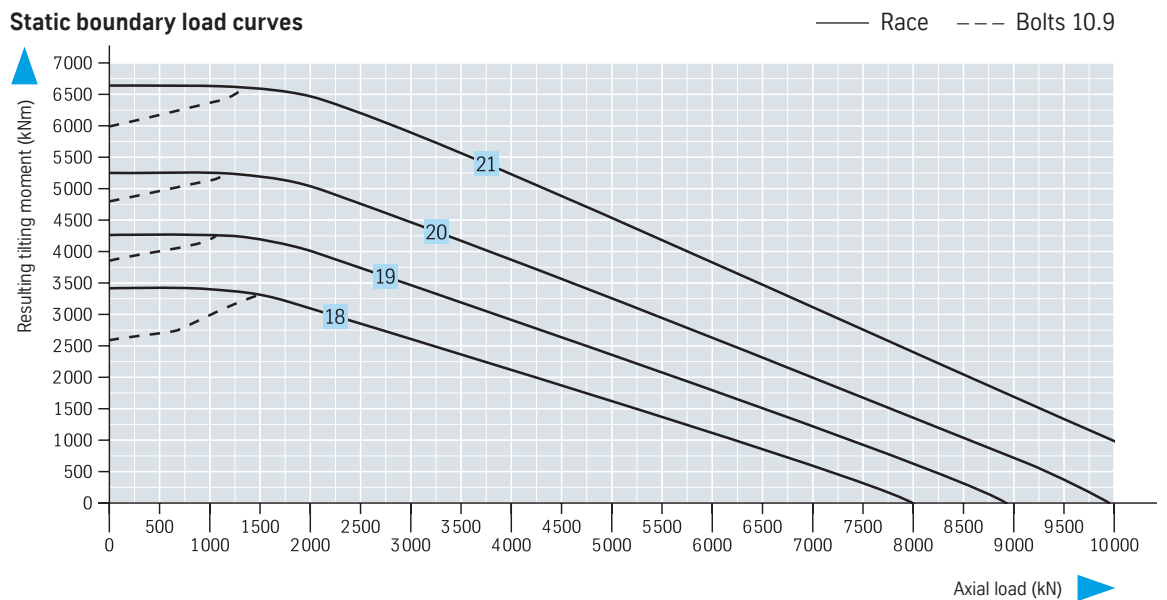

Attachment					Gearing								Miscellaneous	
$\varnothing L_a$ mm	$\varnothing L_i$ mm	n	$\varnothing B$ mm	M mm	d mm	m mm	z	x · m mm	k · m mm	b _{min} mm	X1 kN	X2 kN	kg	n ₁
2005	1795	36	33	30	2100	14	150	+ 7,0	- 1,4	99	127,22	254,43	820	9
2235	2025	48	33	30	2336	16	146	+ 8,0	- 1,6	99	145,39	290,78	931	8
2460	2250	54	33	30	2560	16	160	+ 8,0	- 1,6	99	145,39	290,78	1024	9
2750	2540	60	33	30	2848	16	178	+ 8,0	- 1,6	99	145,39	290,78	1142	12

Diameter tolerances

Machined diameters with untoleranced drawing dimensions have the following tolerances:

- ≤ 2000 mm ± 3,5 mm
- ≤ 4000 mm ± 5,0 mm

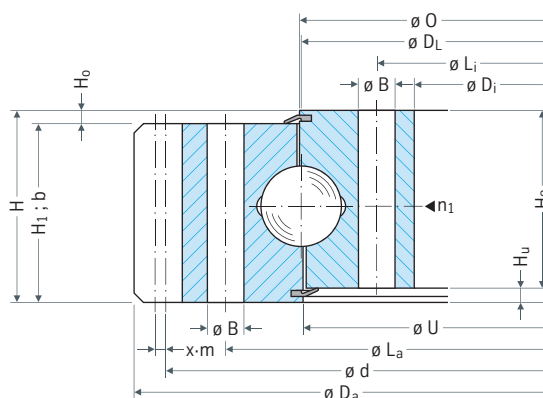

Bearing selection series 06

Utilization period curves – 30 000 revolutions

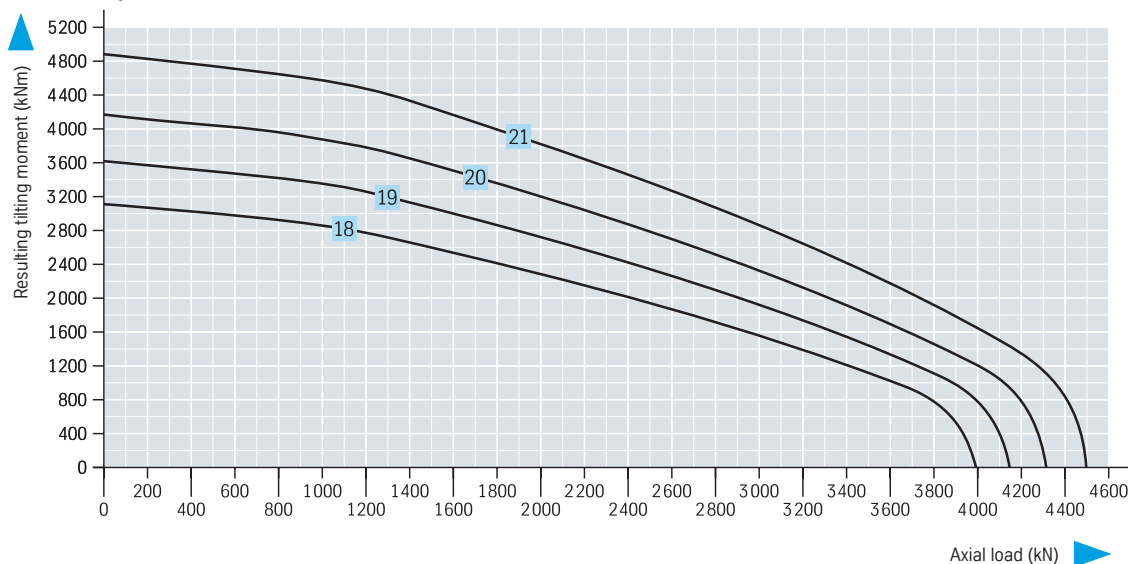



Series 06 Single-row four-point bearing

Bearing with internal gearing		Geometry									
Drawing number		$\varnothing D_L$ mm	$\varnothing D_a$ mm	$\varnothing D_i$ mm	H mm	$\varnothing O$ mm	$\varnothing U$ mm	H ₁ mm	H ₂ mm	H _U mm	H _O mm
22	062.25.0886.106.11.1504 062.25.0886.109.21.1504	886	980	784	77	885	887	67	56	21	10
23	062.25.1077.308.11.1504 062.25.1077.304.21.1504	1077	1170	960	84	1076	1078	66	64	20	18

Ring gear normalised

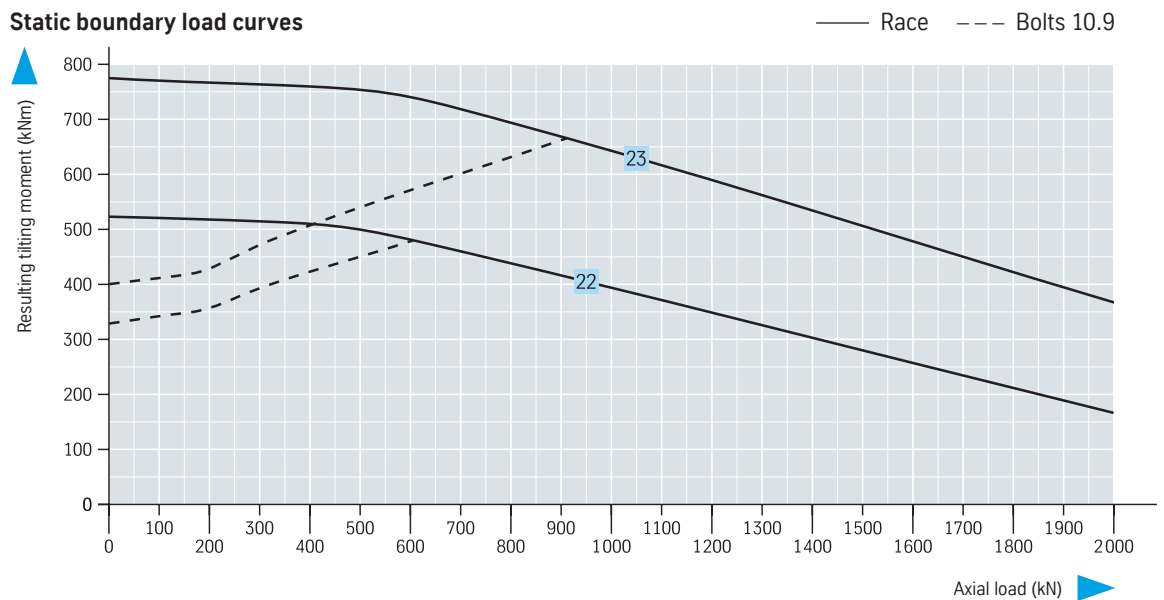
Ring gear annealed



Attachment						Gearing								Miscellaneous		
$\varnothing L_a$ mm	$\varnothing L_l$ mm	n	$\varnothing B$ mm	M mm	t mm	d mm	m mm	z	x · m mm	b mm	$\varnothing Z_u$ mm	$\varnothing h_u$ mm	X1 kN	X2 kN	 kg	n_1
944	850	36	17,5	16	24	800	8	100	-0,0	62	820	5	28,00 43,13	56,00 86,26	109	6
1134	1040	36	17,5	16	24	980	10	98	-0,0	61	1010	5	34,60 53,15	69,20 106,30	148	6

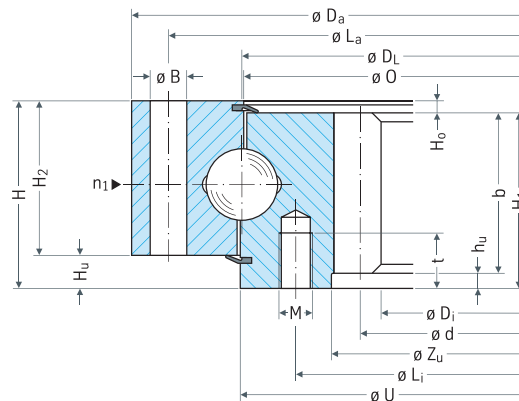

Diameter tolerances

Machined diameters with untoleranced drawing dimensions have the following tolerances:

- ≤ 1000 mm ± 2,5 mm
- ≤ 2000 mm ± 3,5 mm

Bearing selection series 06

Utilization period curves – 30 000 revolutions

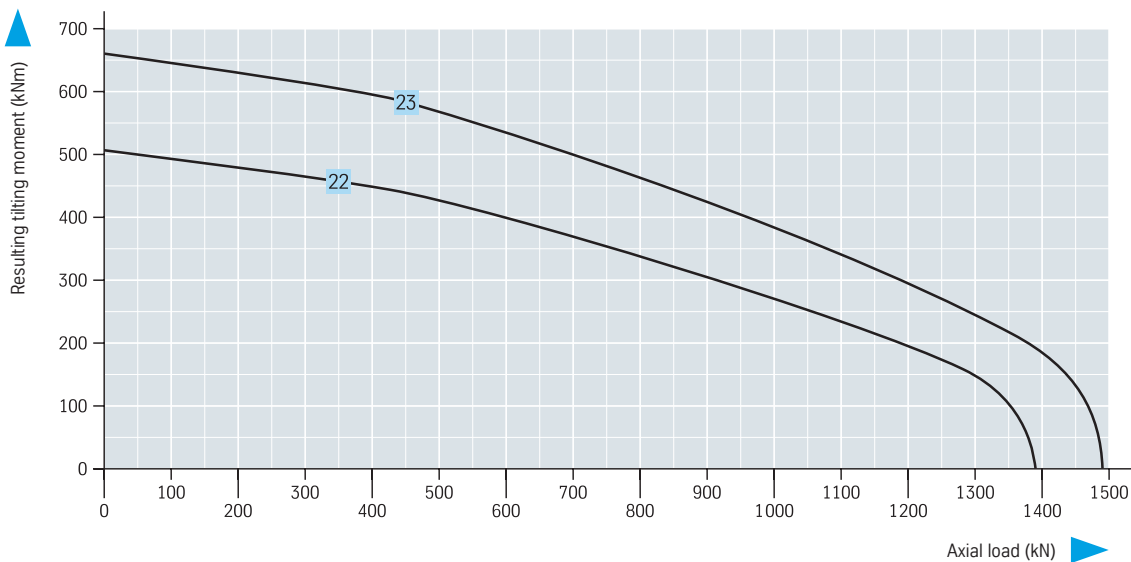



Series 06 Single-row four-point bearing

Bearing with internal gearing		Geometry									
Drawing number		$\varnothing D_L$ mm	$\varnothing D_a$ mm	$\varnothing D_i$ mm	H mm	$\varnothing O$ mm	$\varnothing U$ mm	H ₁ mm	H ₂ mm	H _u mm	H _o mm
24	062.20.0400.000.11.1503 062.20.0400.001.21.1503	400	475	300	55	399	401	46	46	9	9
25	062.20.0450.000.11.1503 062.20.0450.001.21.1503	450	531	345	55	449	451	46	46	9	9
26	062.20.0560.000.11.1503 062.20.0560.001.21.1503	560	641	450	55	559	561	46	46	9	9
27	062.20.0630.000.11.1503 062.20.0630.001.21.1503	630	717	516	55	629	631	46	46	9	9
28	062.20.0710.000.11.1503 062.20.0710.001.21.1503	710	797	594	55	709	711	46	46	9	9

Ring gear normalised

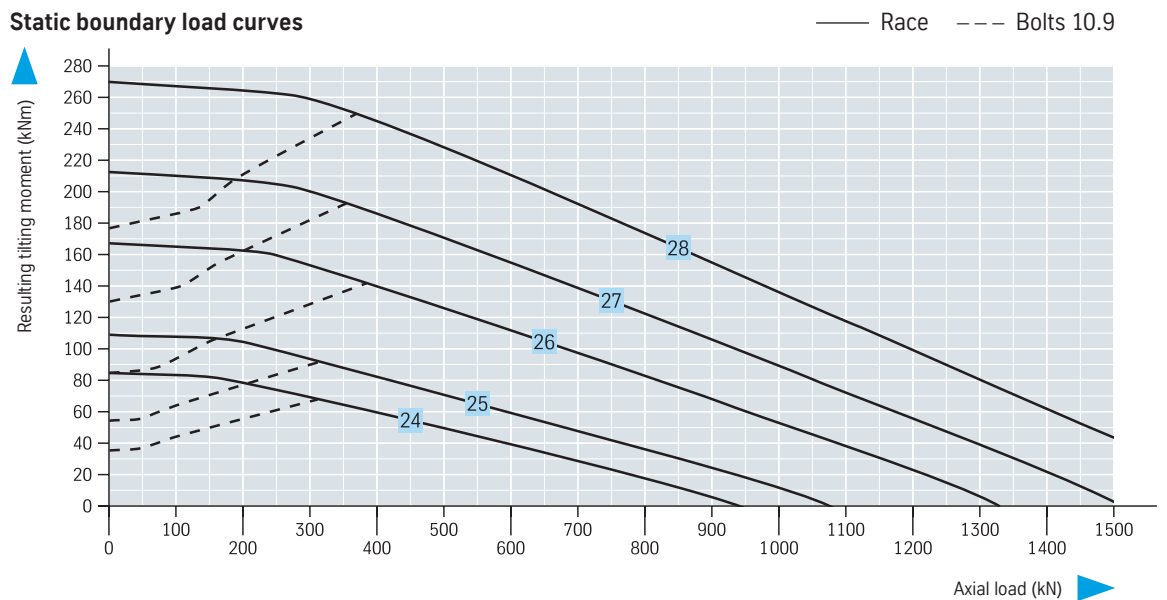
Ring gear annealed



Attachment					Gearing							Miscellaneous	
$\varnothing L_a$ mm	$\varnothing L_i$ mm	n	$\varnothing B$ mm	M mm	d mm	m mm	z	x · m mm	b_{min} mm	X1 kN	X2 kN	 kg	n_1
448	352	16	13,5	12	305	5	61	- 2,5	45	14,13 21,74	28,25 43,47	33	2
500	400	16	15,5	14	350	5	70	- 2,5	45	14,13 21,74	28,25 43,47	38	2
610	510	20	15,5	14	456	6	76	- 3,0	45	16,95 26,08	33,91 52,16	51	4
682	578	20	17,5	16	522	6	87	- 3,0	45	16,95 26,08	33,91 52,16	59	4
762	658	24	17,5	16	600	6	100	- 3,0	45	16,95 26,08	33,91 52,16	68	4

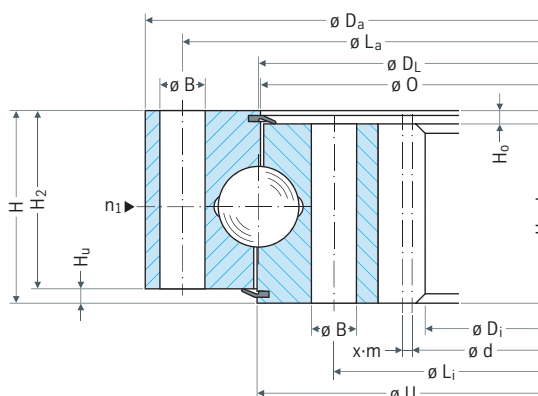

Diameter tolerances

Machined diameters with untoleranced drawing dimensions have the following tolerances:

- ≤ 315 mm ± 1,6 mm
- ≤ 1000 mm ± 2,5 mm

Bearing selection series 06

Utilization period curves – 30 000 revolutions

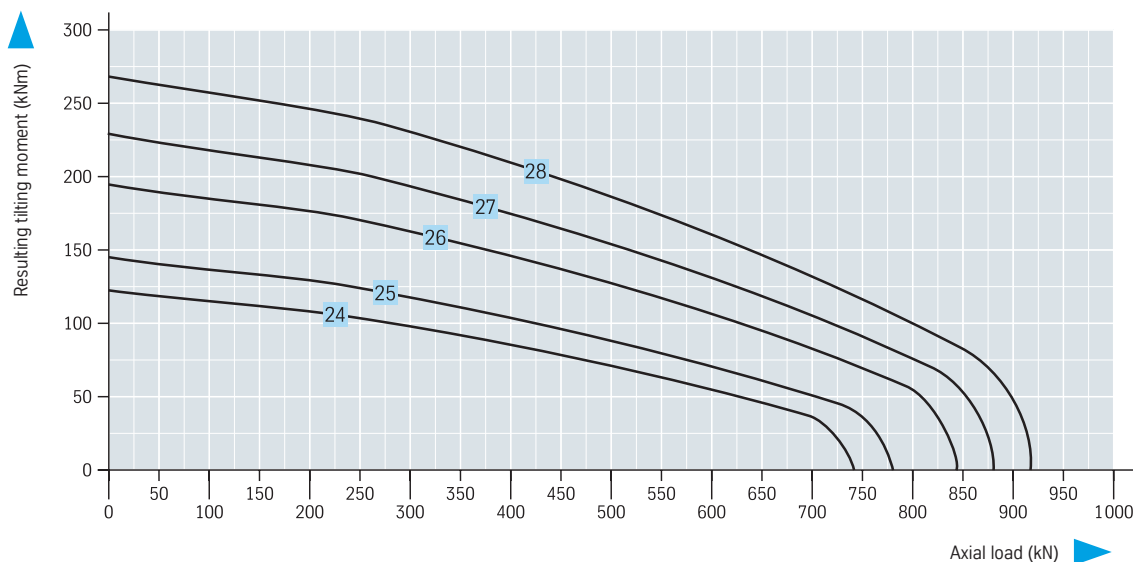

Series 06 Single-row four-point bearing

Bearing with internal gearing		Geometry									
Drawing number		$\varnothing D_L$ mm	$\varnothing D_a$ mm	$\varnothing D_i$ mm	H mm	$\varnothing O$ mm	$\varnothing U$ mm	H ₁ mm	H ₂ mm	H _u mm	H _o mm
29	062.25.0886.800.11.1504 062.25.0886.801.21.1504	886	980	752	63	885	887	54	54	9	9
30	062.25.1077.890.11.1503 062.25.1077.891.21.1503	1077	1169	930	63	1076	1078	54	54	9	9
31	062.25.1180.000.11.1504 062.25.1180.001.21.1504	1188	1287	1020	69	1179	1181	60	54	15	9

Ring gear normalised
 Ring gear annealed

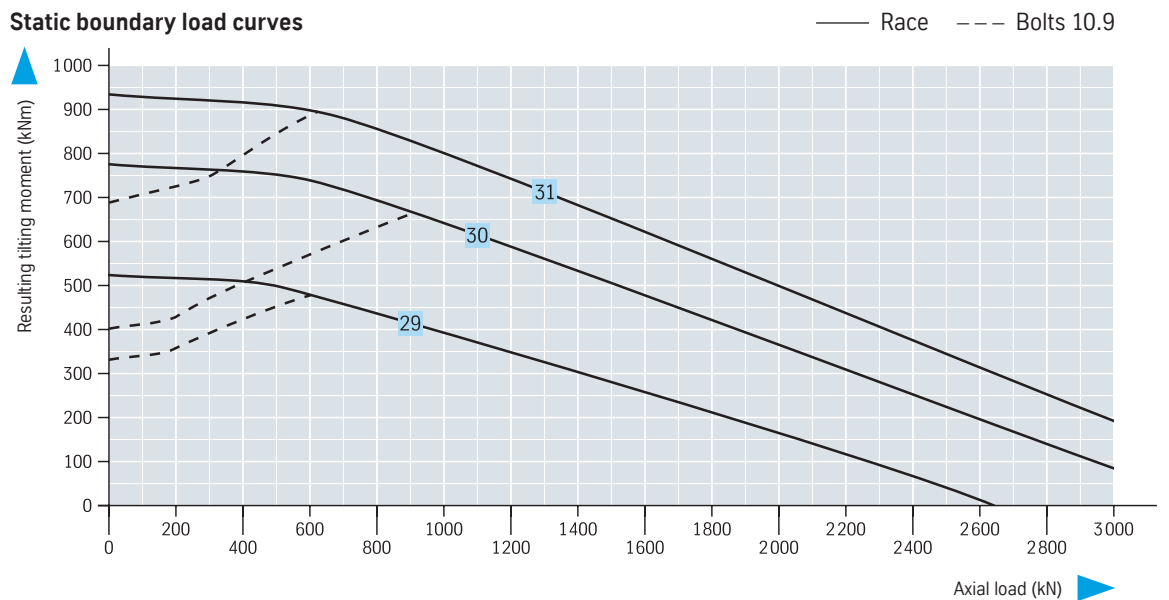

Attachment					Gearing							Miscellaneous	
$\varnothing L_a$ mm	$\varnothing L_l$ mm	n	$\varnothing B$ mm	M mm	d mm	m mm	z	x · m mm	b_{min} mm	X1 kN	X2 kN	 kg	n_1
944	827	36	17,5	16	760	8	95	- 4,0	53	26,63 40,97	53,26 81,93	111	4
1134	1017	36	17,5	16	940	10	94	- 5,0	53	33,28 51,20	66,56 102,41	140	6
1243	1117	36	22	20	1030	10	103	- 5,0	59	37,02 57,00	74,05 114,01	185	6

Diameter tolerances

Machined diameters with untoleranced drawing dimensions have the following tolerances:

- ≤ 1000 mm ± 2,5 mm
- ≤ 2000 mm ± 3,5 mm

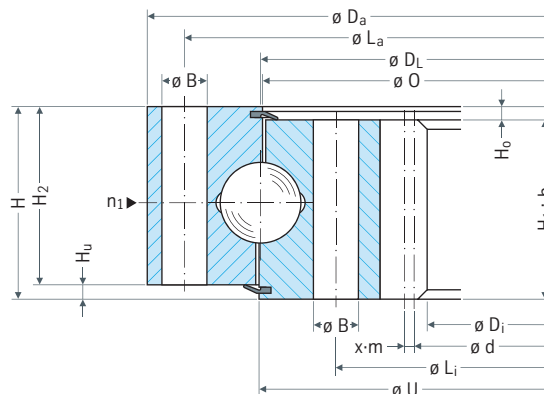

Bearing selection series 06

Utilization period curves – 30 000 revolutions

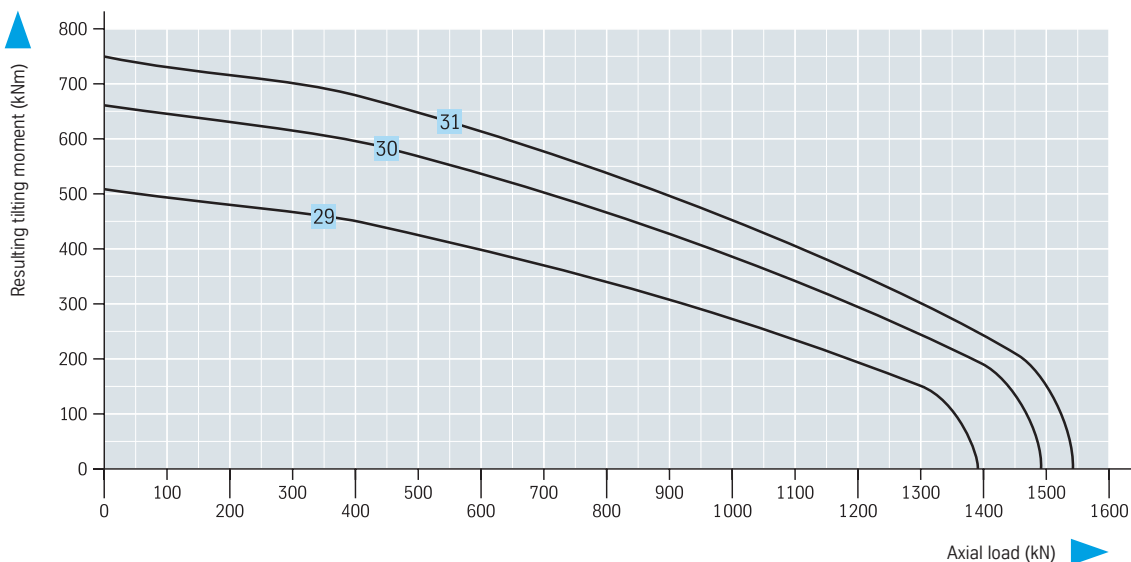



Series 06 Single-row four-point bearing

Bearing with internal gearing		Geometry									
Drawing number		$\varnothing D_L$ mm	$\varnothing D_a$ mm	$\varnothing D_i$ mm	H mm	$\varnothing O$ mm	$\varnothing U$ mm	H ₁ mm	H ₂ mm	H _U mm	H _o mm
32	062.30.1120.000.11.1504 062.30.1120.001.21.1504	1120	1232	960	79	1118	1121	70	63	16	9
33	062.30.1250.000.11.1504 062.30.1250.001.21.1504	1250	1362	1090	79	1248	1251	70	63	16	9
34	062.30.1400.000.11.1504 062.30.1400.001.21.1504	1400	1512	1224	89	1398	1401	80	63	26	9
35	062.30.1600.000.11.1504 062.30.1600.001.21.1504	1600	1712	1428	89	1598	1601	80	63	26	9

Ring gear normalised

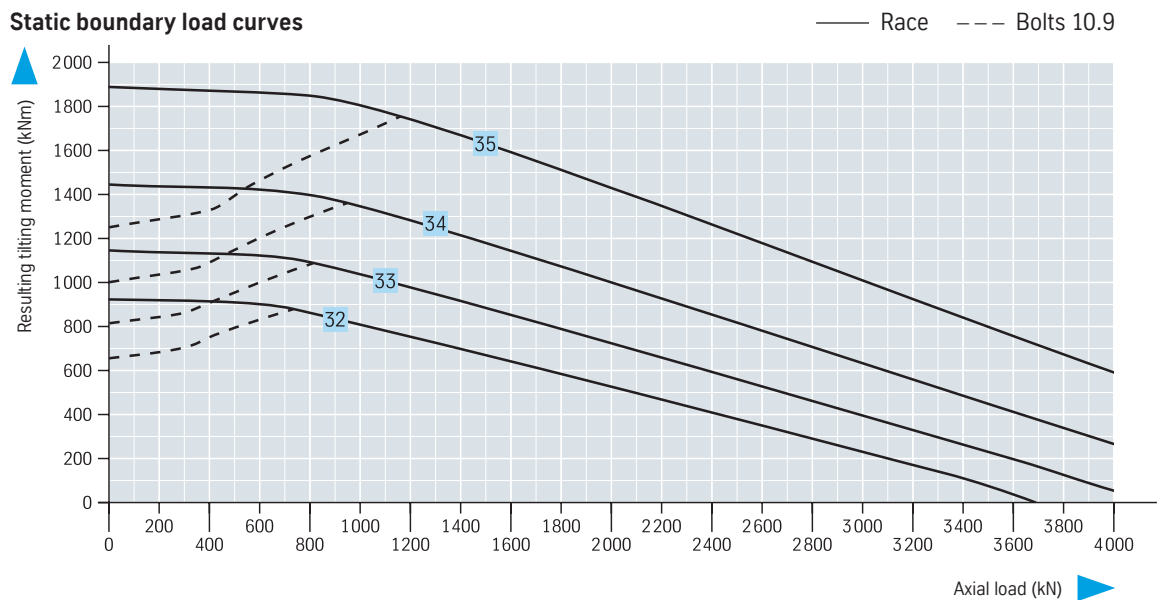
Ring gear annealed



Attachment					Gearing							Miscellaneous	
$\varnothing L_a$ mm	$\varnothing L_i$ mm	n	$\varnothing B$ mm	M mm	d mm	m mm	z	x · m mm	b_{min} mm	X1 kN	X2 kN	 kg	n_1
1188	1052	36	22	20	970	10	97	- 5,0	69	43,32 66,66	86,64 133,33	206	6
1318	1182	40	22	20	1100	10	110	- 5,0	69	43,32 66,66	86,64 133,33	231	8
1468	1332	44	22	20	1236	12	103	- 6,0	79	59,55 87,00	119,09 174,00	296	11
1668	1532	48	22	20	1440	12	120	- 6,0	79	59,55 87,00	119,09 174,00	334	8

Diameter tolerances

Machined diameters with untoleranced drawing dimensions have the following tolerances:

- ≤ 1000 mm ± 2,5 mm
- ≤ 2000 mm ± 3,5 mm

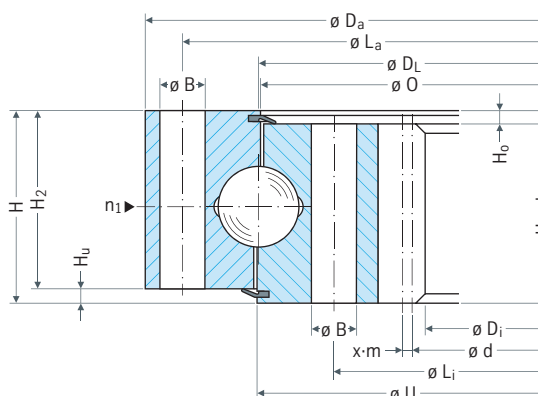

Bearing selection series 06

Utilization period curves – 30 000 revolutions

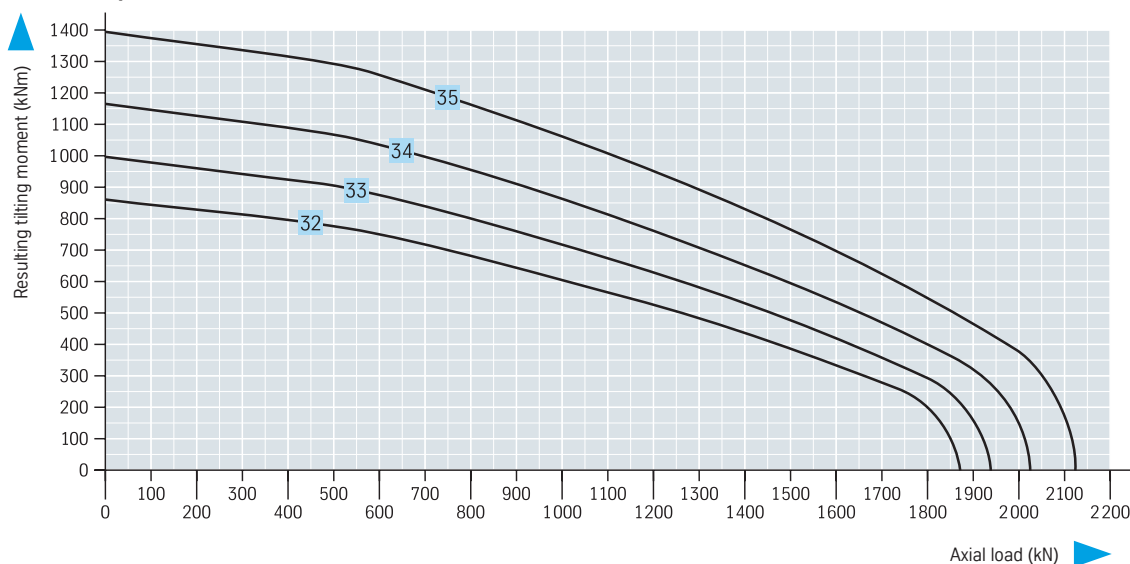

Series 06 Single-row four-point bearing

Bearing with internal gearing		Geometry									
Drawing number		$\varnothing D_L$ mm	$\varnothing D_a$ mm	$\varnothing D_i$ mm	H mm	$\varnothing O$ mm	$\varnothing U$ mm	H ₁ mm	H ₂ mm	H _u mm	H _o mm
36	062.40.1500.000.19.1504 062.40.1500.001.29.1504	1500	1634	1308	94	1498	1501	85	81	13	9
37	062.40.1700.007.19.1503 062.40.1700.008.29.1503	1700	1834	1498	94	1698	1701	85	81	13	9

Ring gear normalised

Ring gear annealed

Static boundary load curves

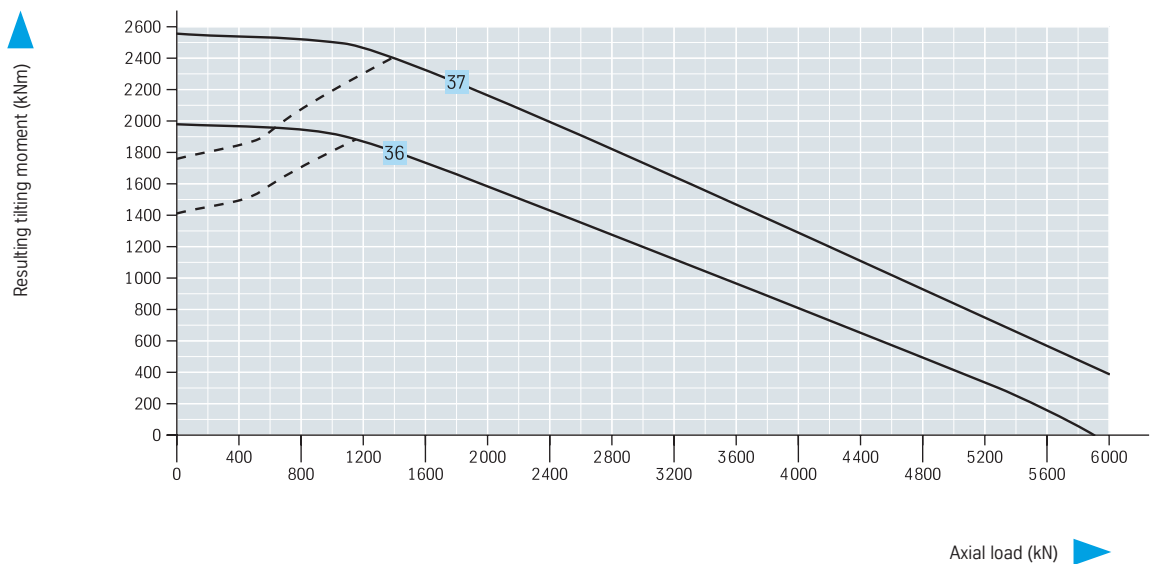

Attachment					Gearing							Miscellaneous	
$\emptyset L_a$ mm	$\emptyset L_i$ mm	n	$\emptyset B$ mm	M mm	d mm	m mm	z	x · m mm	b_{min} mm	X1 kN	X2 kN	 kg	n_1
1582	1418	40	26	24	1320	12	110	- 6,0	84	63,25 92,50	126,49 185,00	410	8
1782	1618	44	26	24	1512	14	108	- 7,0	84	73,82 107,92	147,64 215,83	475	11

Diameter tolerances

Machined diameters with untoleranced drawing dimensions have the following tolerances:

$\leq 2000 \text{ mm} \pm 3,5 \text{ mm}$

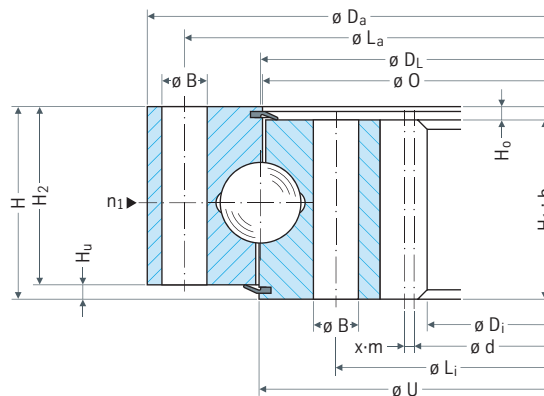

Bearing selection series 06

Utilization period curves – 30 000 revolutions

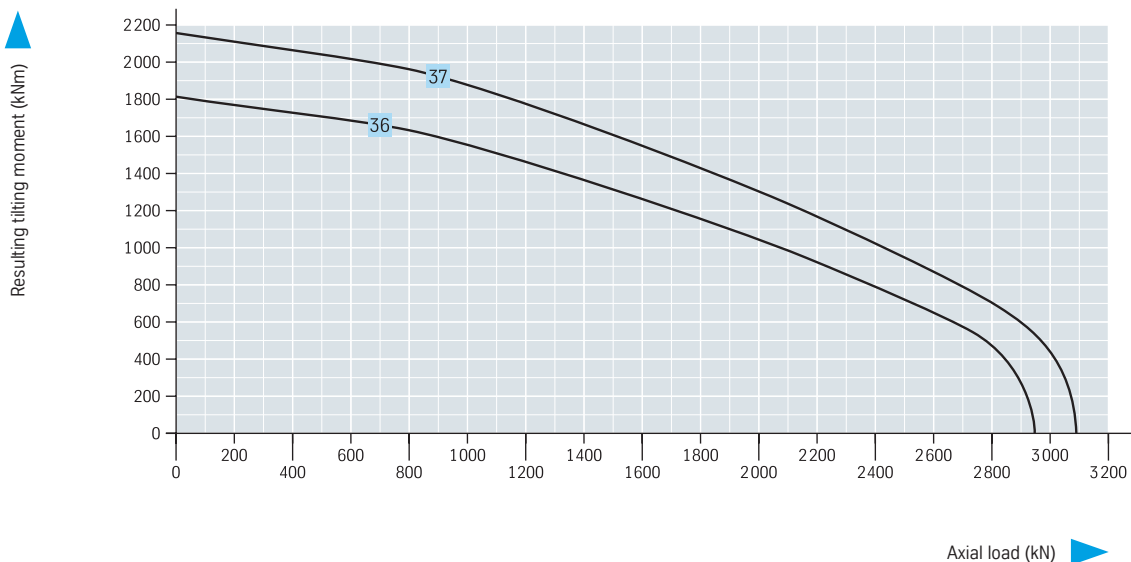

Series 06 Single-row four-point bearing

Bearing with internal gearing		Geometry									
Drawing number		$\varnothing D_L$ mm	$\varnothing D_a$ mm	$\varnothing D_i$ mm	H mm	$\varnothing O$ mm	$\varnothing U$ mm	H ₁ mm	H ₂ mm	H _u mm	H _o mm
38	062.50.1800.001.49.1504	1800	1971	1554	109	1798	1802	100	99	10	9
39	062.50.2000.001.49.1504	2000	2171	1764	109	1998	2002	100	99	10	9
40	062.50.2240.001.49.1504	2240	2411	1984	109	2238	2242	100	99	10	9
41	062.50.2490.001.49.1504	2490	2661	2240	109	2488	2492	100	99	10	9
42	062.50.2800.001.49.1504	2800	2971	2544	109	2798	2802	100	99	10	9

Ring gear annealed

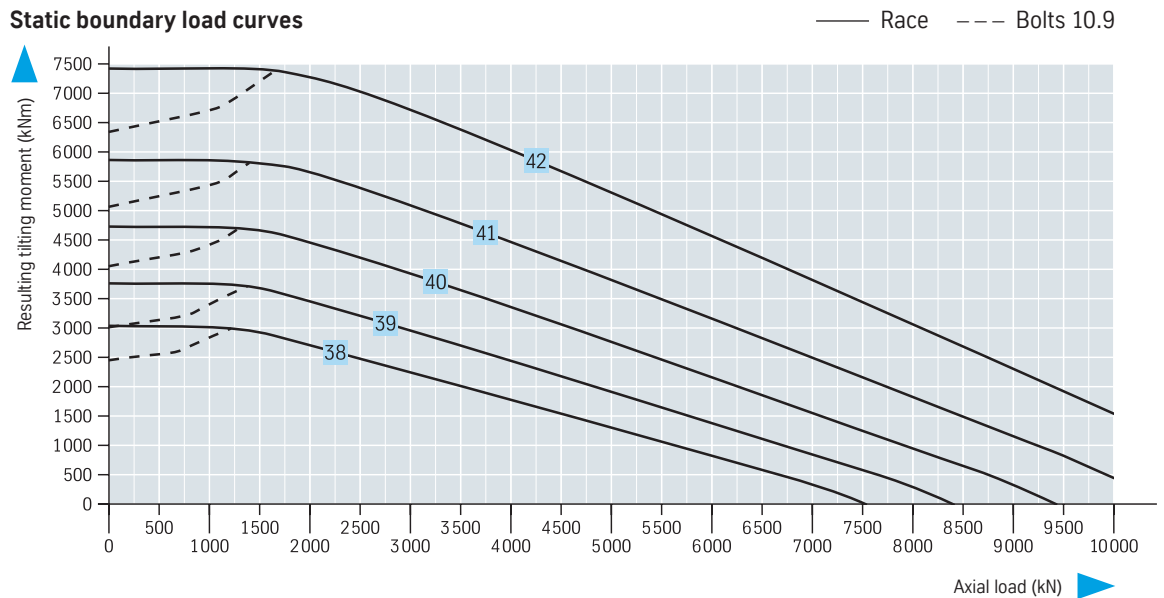

Attachment					Gearing							Miscellaneous	
$\varnothing L_a$ mm	$\varnothing L_l$ mm	n	$\varnothing B$ mm	M mm	d mm	m mm	z	x · m mm	b_{min} mm	X1 kN	X2 kN	 kg	n_1
1905	1695	36	33	30	1568	14	112	- 7,0	99	127,22	254,43	762	9
2105	1895	40	33	30	1778	14	127	- 7,0	99	127,22	254,43	843	8
2345	2135	48	33	30	2000	16	125	- 8,0	99	145,33	290,66	961	8
2595	2385	54	33	30	2256	16	141	- 8,0	99	145,33	290,66	1053	9
2905	2695	60	33	30	2560	16	160	- 8,0	99	145,33	290,66	1205	12

Diameter tolerances

Machined diameters with untoleranced drawing dimensions have the following tolerances:

- ≤ 2000 mm ± 3,5 mm
- ≤ 4000 mm ± 5,0 mm

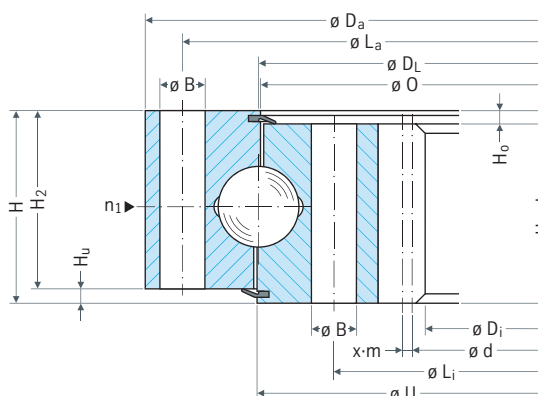

Bearing selection series 06

Utilization period curves – 30 000 revolutions

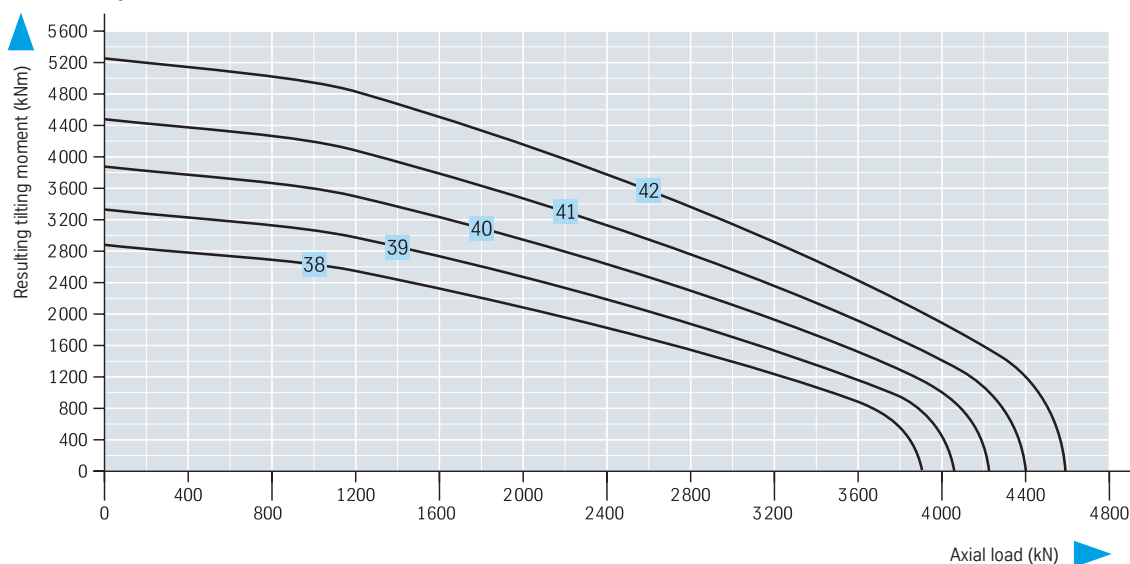

Series 09

Double-row four-point bearing

Bearing with external gearing		Geometry									
Drawing number		$\varnothing D_L$ mm	$\varnothing D_a$ mm	$\varnothing D_i$ mm	H mm	$\varnothing O$ mm	$\varnothing U$ mm	H ₁ mm	H ₂ mm	H _u mm	H _o mm
1	091.20.1006.990.11.1503 091.20.1006.991.21.1503	1006	1168,0	893	92	1012	1005	83	83	9	9
2	091.20.1146.990.11.1503 091.20.1146.991.21.1503	1146	1308,0	1033	92	1152	1145	83	83	9	9
3	091.20.1246.990.11.1503 091.20.1246.991.21.1503	1246	1408,0	1133	92	1252	1245	83	83	9	9
4	091.25.1154.990.11.1503 091.25.1154.991.21.1503	1154	1341,6	1023	104	1160	1153	95	95	9	9
5	091.25.1310.990.11.1503 091.25.1310.991.21.1503	1310	1497,6	1179	104	1316	1309	95	95	9	9
6	091.25.1502.990.11.1503 091.25.1502.991.21.1503	1502	1689,6	1371	104	1508	1501	95	95	9	9

Ring gear normalised

Ring gear annealed

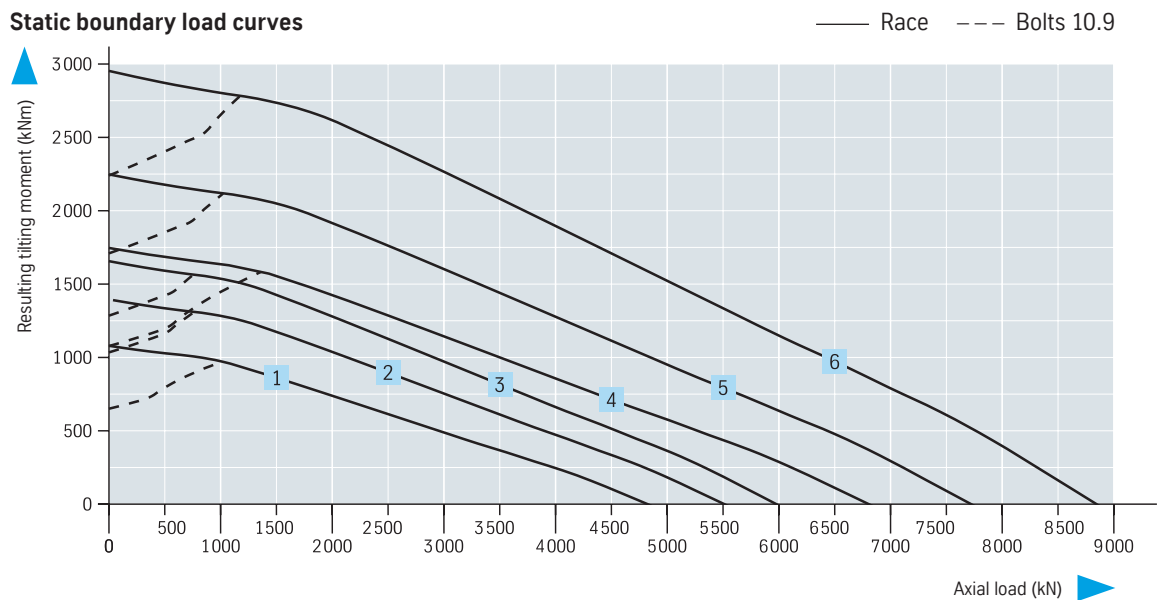

Attachment					Gearing									Miscellaneous	
$\varnothing L_a$ mm	$\varnothing L_l$ mm	n	$\varnothing B$ mm	M mm	d mm	m mm	z	x · m mm	k · m mm	b _{min} mm	$\varnothing Z_u$ mm	X1 kN	X2 kN	kg	n ₁
1075	942	40	22	20	1140	10	114	5	-1,0	82	1119	51,50 79,23	103,00 158,45	242	4
1215	1082	56	22	20	1280	10	128	5	-1,0	82	1259	51,50 79,23	103,00 158,45	270	4
1315	1182	64	22	20	1380	10	138	5	-1,0	82	1359	51,50 79,23	103,00 158,45	288	4
1232	1081	40	26	24	1308	12	109	6	-1,2	94	1284	70,84 103,54	141,68 207,07	364	4
1388	1237	56	26	24	1464	12	122	6	-1,2	94	1440	70,84 103,54	141,68 207,07	400	4
1580	1429	64	26	24	1656	12	138	6	-1,2	94	1632	70,84 103,54	141,68 207,07	461	4

Diameter tolerances

Machined diameters with untoleranced drawing dimensions have the following tolerances:

- ≤ 1000 mm ± 2,5 mm
- ≤ 2000 mm ± 3,5 mm

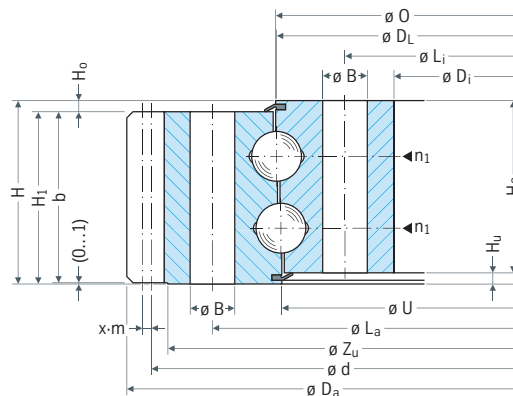

Utilization period curves – 30 000 revolutions

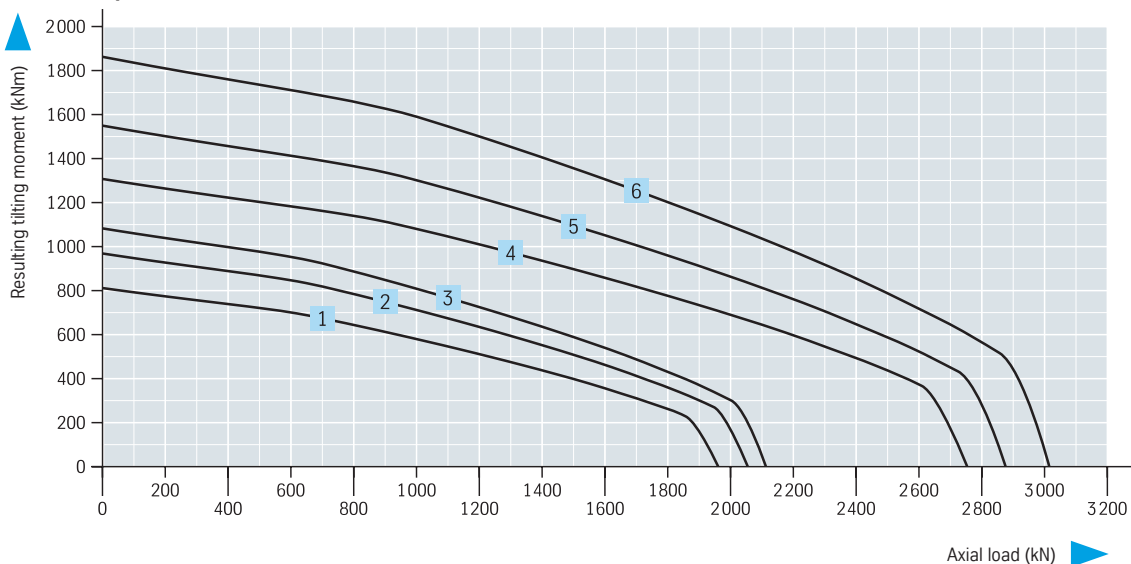

Bearing selection series 09

Series 09 Double-row four-point bearing

Bearing with internal gearing		Geometry									
Drawing number		$\varnothing D_L$ mm	$\varnothing D_a$ mm	$\varnothing D_i$ mm	H mm	$\varnothing O$ mm	$\varnothing U$ mm	H ₁ mm	H ₂ mm	H _u mm	H _o mm
1	092.20.1006.990.11.1503 092.20.1006.991.21.1503	1006	1124	850	92	1005	1012	83	83	9	9
2	092.20.1146.990.11.1503 092.20.1146.991.21.1503	1146	1264	990	92	1145	1152	83	83	9	9
3	092.20.1246.990.11.1503 092.20.1246.991.21.1503	1246	1364	1090	92	1245	1252	83	83	9	9
4	092.25.1154.990.11.1503 092.25.1154.991.21.1503	1154	1290	972	104	1153	1160	95	95	9	9
5	092.25.1310.990.11.1503 092.25.1310.991.21.1503	1310	1446	1128	104	1309	1316	95	95	9	9
6	092.25.1502.990.11.1503 092.25.1502.991.21.1503	1502	1638	1320	104	1501	1508	95	95	9	9

Ring gear normalised

Ring gear annealed

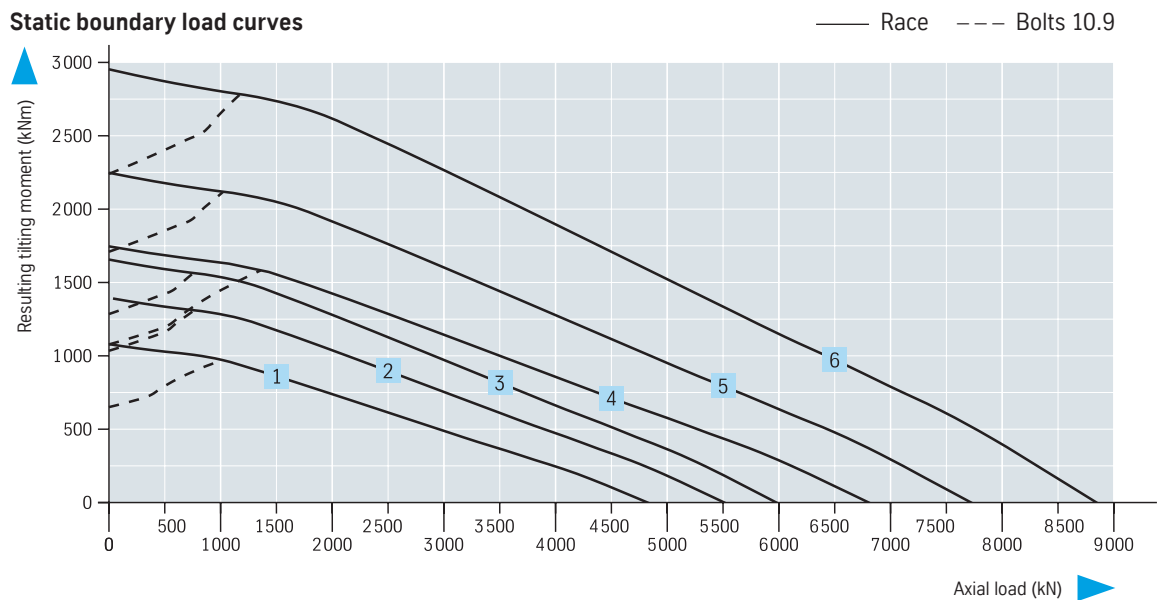

Attachment					Gearing									Miscellaneous	
$\emptyset L_a$ mm	$\emptyset L_l$ mm	n	$\emptyset B$ mm	M mm	d mm	m mm	z	x · m mm	k · m mm	b_{min} mm	$\emptyset Z_u$ mm	X1 kN	X2 kN	kg	n_1
1075	942	40	22	20	860	10	86	- 5	0	82	898	51,50 79,23	103,00 158,45	233	4
1215	1082	56	22	20	1000	10	100	- 5	0	82	1038	51,50 79,23	103,00 158,45	259	4
1315	1182	64	22	20	1100	10	110	- 5	0	82	1138	51,50 79,23	103,00 158,45	281	4
1232	1081	40	26	24	984	12	82	- 6	0	94	1029	70,84 103,54	141,68 207,07	351	4
1388	1237	56	26	24	1140	12	95	- 6	0	94	1185	70,84 103,54	141,68 207,07	389	4
1580	1429	64	26	24	1332	12	111	- 6	0	94	1377	70,84 103,54	141,68 207,07	446	4

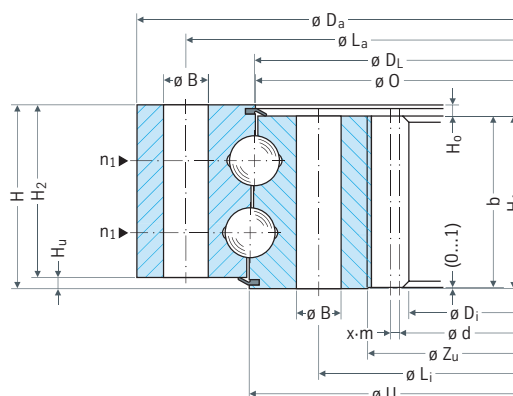

Diameter tolerances

Machined diameters with untoleranced drawing dimensions have the following tolerances:

- ≤ 1000 mm ± 2,5 mm
- ≤ 2000 mm ± 3,5 mm

Utilization period curves – 30 000 revolutions

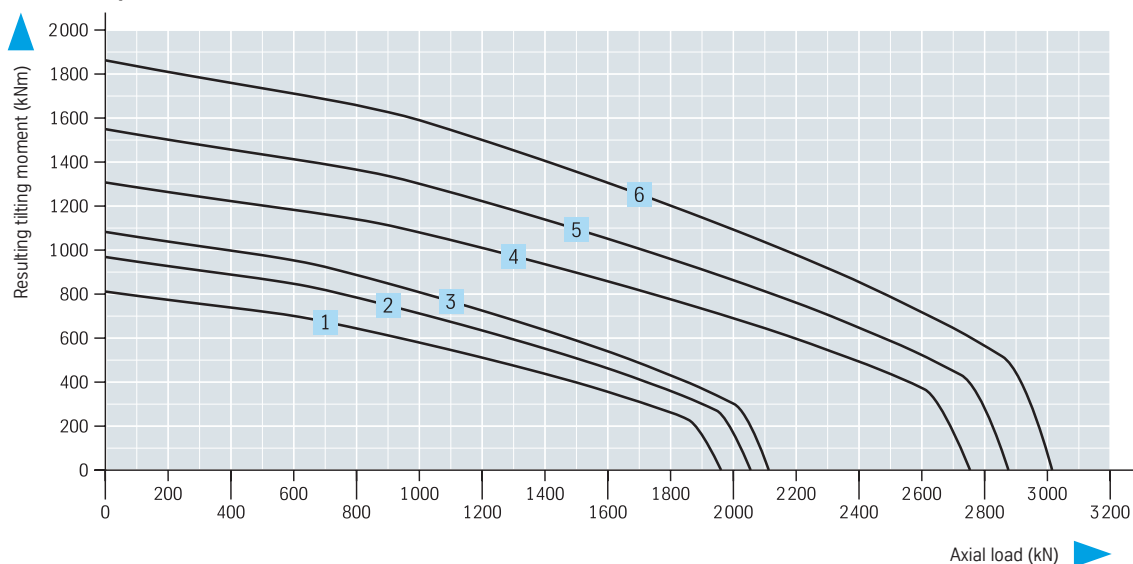

Bearing selection series 09

Series 09 Double-row four-point bearing

Bearing with external gearing		Geometry									
Drawing number		$\varnothing D_L$ mm	$\varnothing D_a$ mm	$\varnothing D_i$ mm	H mm	$\varnothing O$ mm	$\varnothing U$ mm	H ₁ mm	H ₂ mm	H _u mm	H _o mm
7	091.30.1415.990.11.1502 091.30.1415.991.21.1502	1415	1617,6	1270	119	1423	1413	110	110	9	9
8	091.30.1607.990.11.1502 091.30.1607.991.21.1502	1607	1809,6	1462	119	1615	1605	110	110	9	9
9	091.30.1799.990.11.1502 091.30.1799.991.21.1502	1799	2001,6	1654	119	1807	1797	110	110	9	9

Ring gear normalised

Ring gear annealed

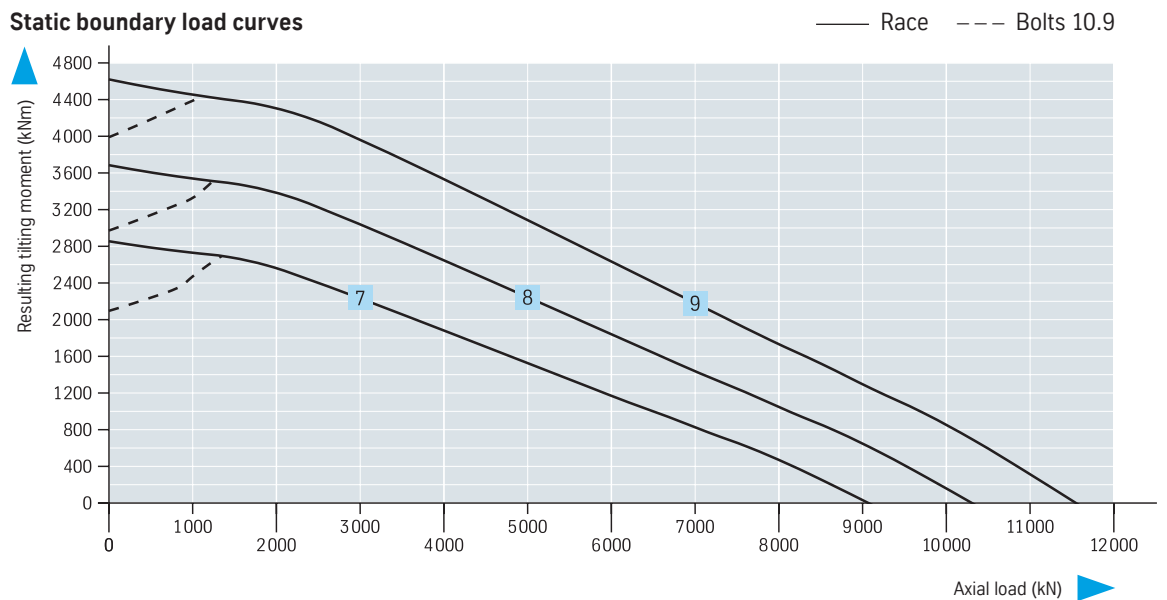

Attachment					Gearing									Miscellaneous	
$\varnothing L_a$ mm	$\varnothing L_l$ mm	n	$\varnothing B$ mm	M mm	d mm	m mm	z	$x \cdot m$ mm	$k \cdot m$ mm	b_{min} mm	$\varnothing Z_u$ mm	X1 kN	X2 kN	kg	n_1
1500	1336	48	30	27	1584	12	132	6	-1,2	109	1560	82,14 120,06	164,29 240,12	552	6
1692	1528	60	30	27	1776	12	148	6	-1,2	109	1752	82,14 120,06	164,29 240,12	619	6
1884	1720	72	30	27	1968	12	164	6	-1,2	109	1944	82,14 120,06	164,29 240,12	685	8

Diameter tolerances

Machined diameters with untoleranced drawing dimensions have the following tolerances:

- ≤ 2000 mm ± 3,5 mm
- ≤ 4000 mm ± 5,0 mm

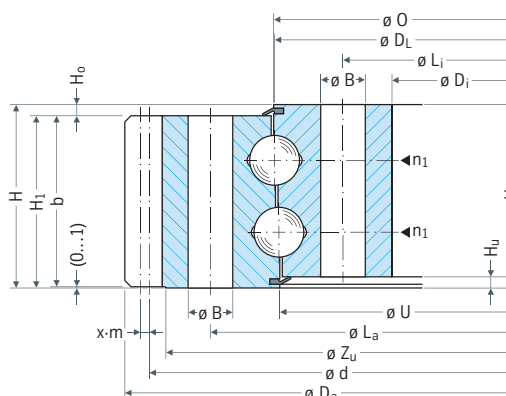

Utilization period curves – 30 000 revolutions

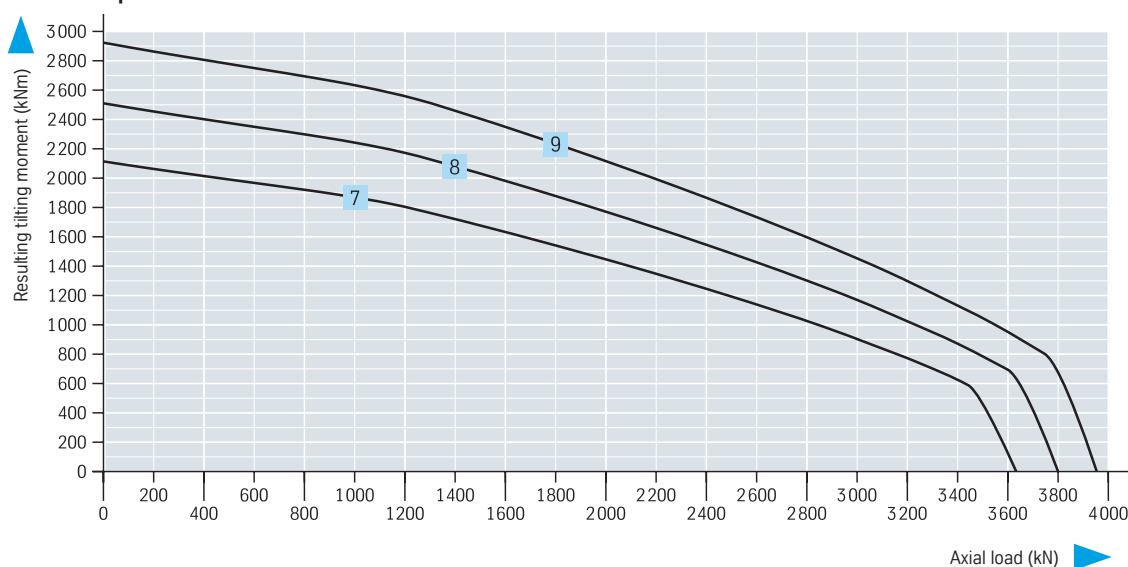

Bearing selection series 09

Series 09 Double-row four-point bearing

Bearing with internal gearing		Geometry									
Drawing number		$\varnothing D_L$ mm	$\varnothing D_a$ mm	$\varnothing D_i$ mm	H mm	$\varnothing O$ mm	$\varnothing U$ mm	H ₁ mm	H ₂ mm	H _u mm	H _o mm
7	092.30.1415.990.11.1502 092.30.1415.991.21.1502	1415	1566	1212	119	1413	1423	110	110	9	9
8	092.30.1607.990.11.1502 092.30.1607.991.21.1502	1607	1758	1404	119	1605	1615	110	110	9	9
9	092.30.1799.990.11.1502 092.30.1799.991.21.1502	1799	1950	1596	119	1797	1807	110	110	9	9

Ring gear normalised

Ring gear annealed

Static boundary load curves

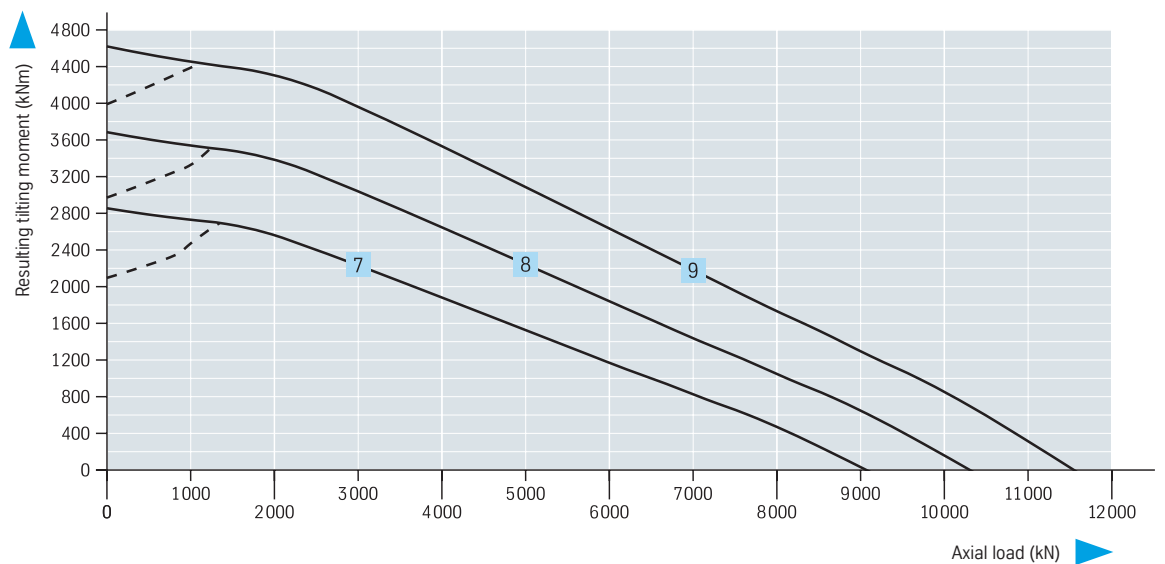

Attachment					Gearing									Miscellaneous	
$\emptyset L_a$ mm	$\emptyset L_l$ mm	n	$\emptyset B$ mm	M mm	d mm	m mm	z	$x \cdot m$ mm	$k \cdot m$ mm	b_{min} mm	$\emptyset Z_u$ mm	X1 kN	X2 kN	kg	n_1
1500	1336	48	30	27	1224	12	102	-6	0	109	1272	82,14 120,06	164,29 240,12	546	6
1692	1528	60	30	27	1416	12	118	-6	0	109	1464	82,14 120,06	164,29 240,12	613	6
1884	1720	72	30	27	1608	12	134	-6	0	109	1656	82,14 120,06	164,29 240,12	682	8

Diameter tolerances

Machined diameters with untoleranced drawing dimensions have the following tolerances:

$\leq 2000 \text{ mm} \pm 3,5 \text{ mm}$

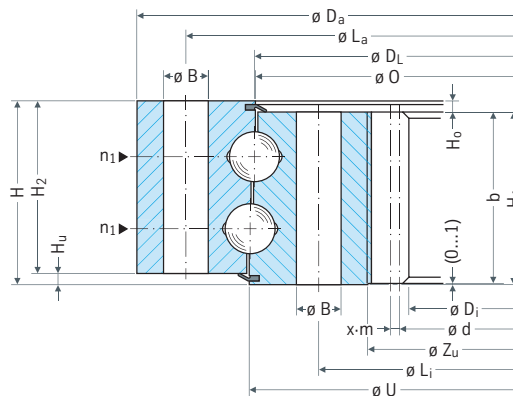

Utilization period curves – 30 000 revolutions

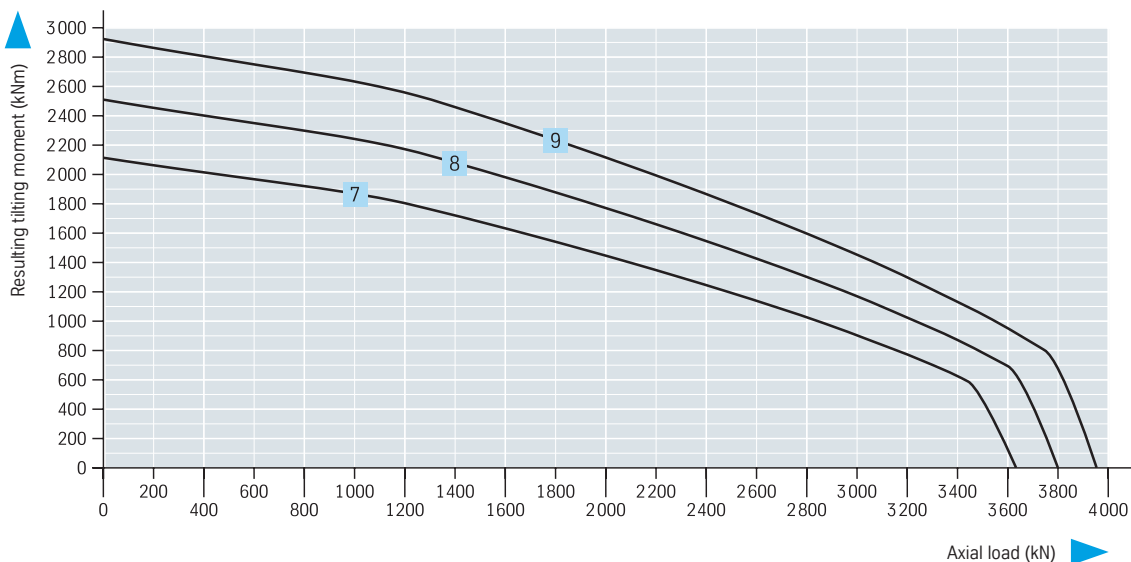

Bearing selection series 09

Series 09 Double-row four-point bearing

Bearing with external gearing		Geometry									
Drawing number		$\varnothing D_L$ mm	$\varnothing D_a$ mm	$\varnothing D_I$ mm	H mm	$\varnothing O$ mm	$\varnothing U$ mm	H ₁ mm	H ₂ mm	H _U mm	H _O mm
10	091.35.1704.990.11.1502 091.35.1704.991.41.1502	1704	1929,2	1544	133	1712	1702	124	124	9	9
11	091.35.1802.990.11.1502 091.35.1802.991.41.1502	1802	2027,2	1642	133	1810	1800	124	124	9	9
12	091.35.1900.990.11.1502 091.35.1900.991.41.1502	1900	2125,2	1740	133	1908	1898	124	124	9	9
13	091.35.2012.990.11.1502 091.35.2012.991.41.1502	2012	2237,2	1852	133	2020	2010	124	124	9	9

Ring gear normalised
 Ring gear annealed

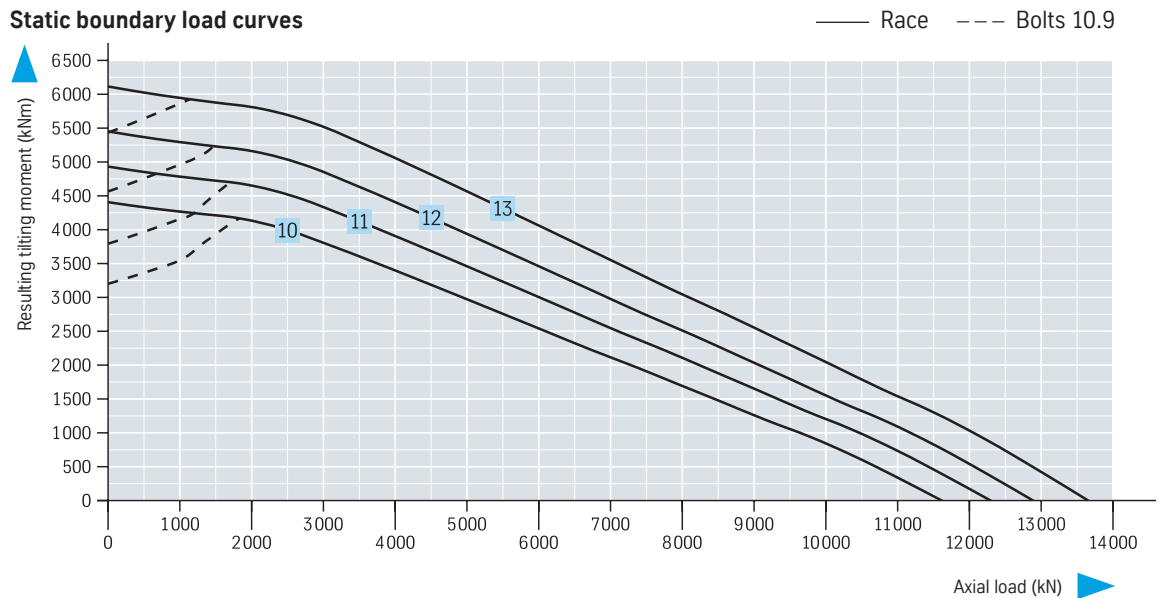

Attachment					Gearing									Miscellaneous	
$\emptyset L_a$ mm	$\emptyset L_l$ mm	n	$\emptyset B$ mm	M mm	d mm	m mm	z	$x \cdot m$ mm	$k \cdot m$ mm	b_{min} mm	$\emptyset Z_u$ mm	X1 kN	X2 kN	kg	n_1
1797	1617	50	33	30	1890	14	135	7	-1,4	123	1863	108,14 158,06	216,29 316,12	828	5
1895	1715	56	33	30	1988	14	142	7	-1,4	123	1961	108,14 158,06	216,29 316,12	870	7
1993	1813	64	33	30	2086	14	149	7	-1,4	123	2059	108,14 158,06	216,29 316,12	908	8
2105	1925	72	33	30	2198	14	157	7	-1,4	123	2171	108,14 158,06	216,29 316,12	954	8

Diameter tolerances

Machined diameters with untoleranced drawing dimensions have the following tolerances:

- ≤ 2000 mm ± 3,5 mm
- ≤ 4000 mm ± 5,0 mm

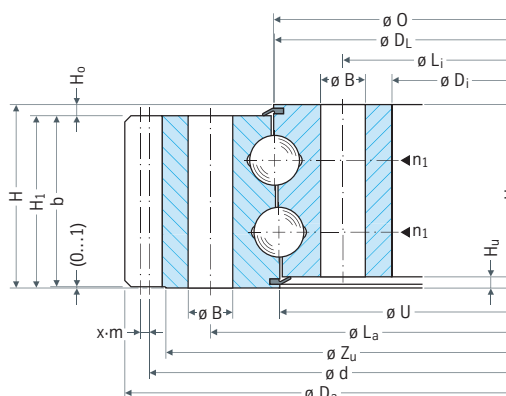

Utilization period curves – 30 000 revolutions

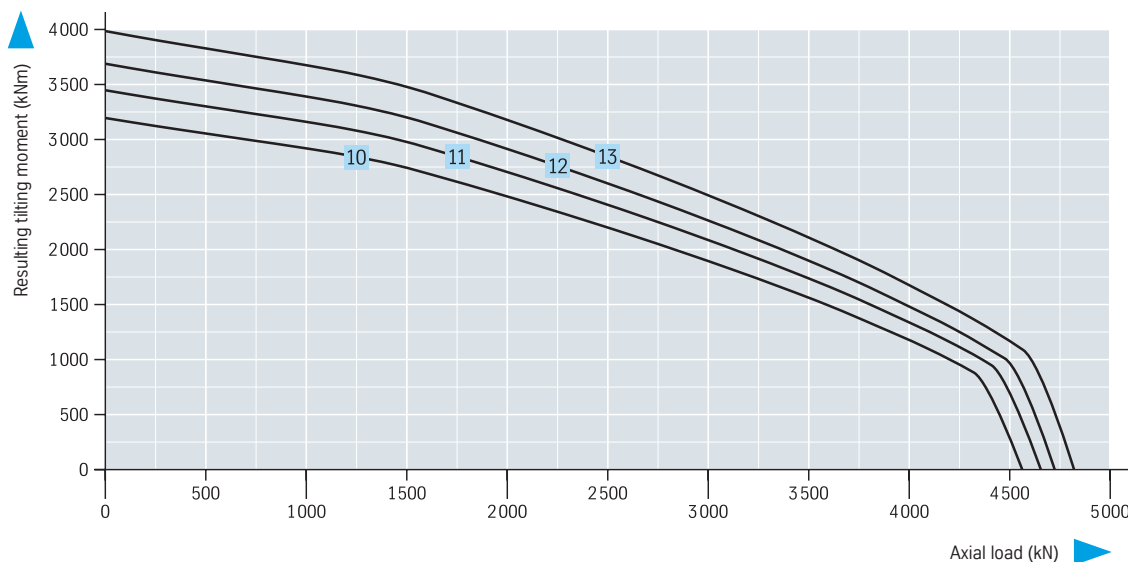

Bearing selection series 09

Attachment					Gearing									Miscellaneous	
$\varnothing L_a$ mm	$\varnothing L_l$ mm	n	$\varnothing B$ mm	M mm	d mm	m mm	z	x · m mm	k · m mm	b _{min} mm	$\varnothing Z_u$ mm	X1 kN	X2 kN	kg	n ₁
1797	1617	50	33	30	1498	14	107	- 7	0	123	1551	108,14 158,06	216,29 316,12	805	5
1895	1715	56	33	30	1596	14	114	- 7	0	123	1649	108,14 158,06	216,29 316,12	847	7
1993	1813	64	33	30	1694	14	121	- 7	0	123	1747	108,14 158,06	216,29 316,12	884	8
2105	1925	72	33	30	1806	14	129	- 7	0	123	1859	108,14 158,06	216,29 316,12	929	8

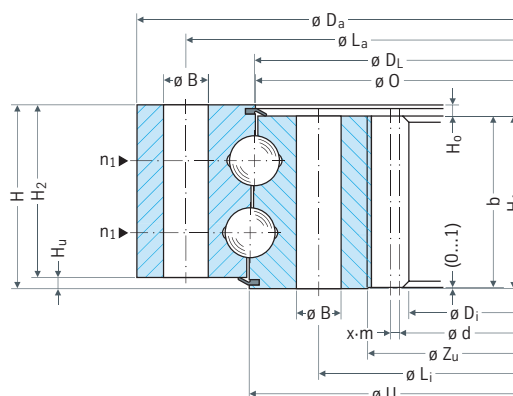

Diameter tolerances

Machined diameters with untoleranced drawing dimensions have the following tolerances:

- ≤ 2000 mm ± 3,5 mm
- ≤ 4000 mm ± 5,0 mm

Utilization period curves – 30 000 revolutions

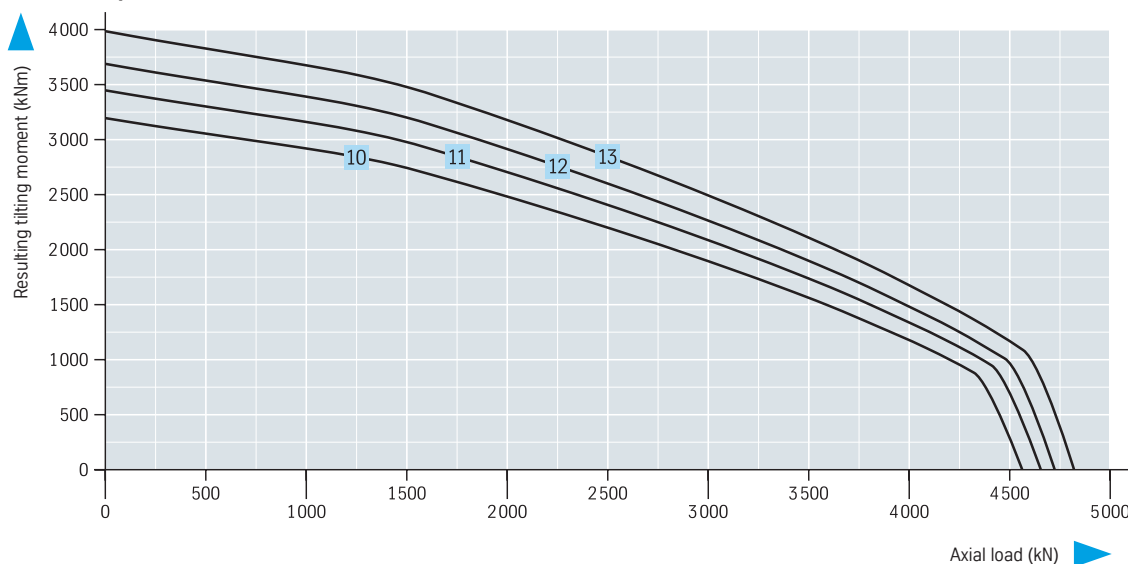

Bearing selection series 09

Series 09 Double-row four-point bearing

Bearing with external gearing		Geometry									
Drawing number		$\varnothing D_L$ mm	$\varnothing D_a$ mm	$\varnothing D_i$ mm	H mm	$\varnothing O$ mm	$\varnothing U$ mm	H ₁ mm	H ₂ mm	H _u mm	H _o mm
14	091.40.2003.990.11.1502 091.40.2003.991.41.1502	2003	2251,2	1820	148	2011	2001	139	139	9	9
15	091.40.2199.990.11.1502 091.40.2199.991.41.1502	2199	2447,2	2016	148	2207	2197	139	139	9	9
16	091.40.2395.990.11.1502 091.40.2395.991.41.1502	2395	2643,2	2212	148	2403	2393	139	139	9	9

Ring gear normalised
 Ring gear annealed

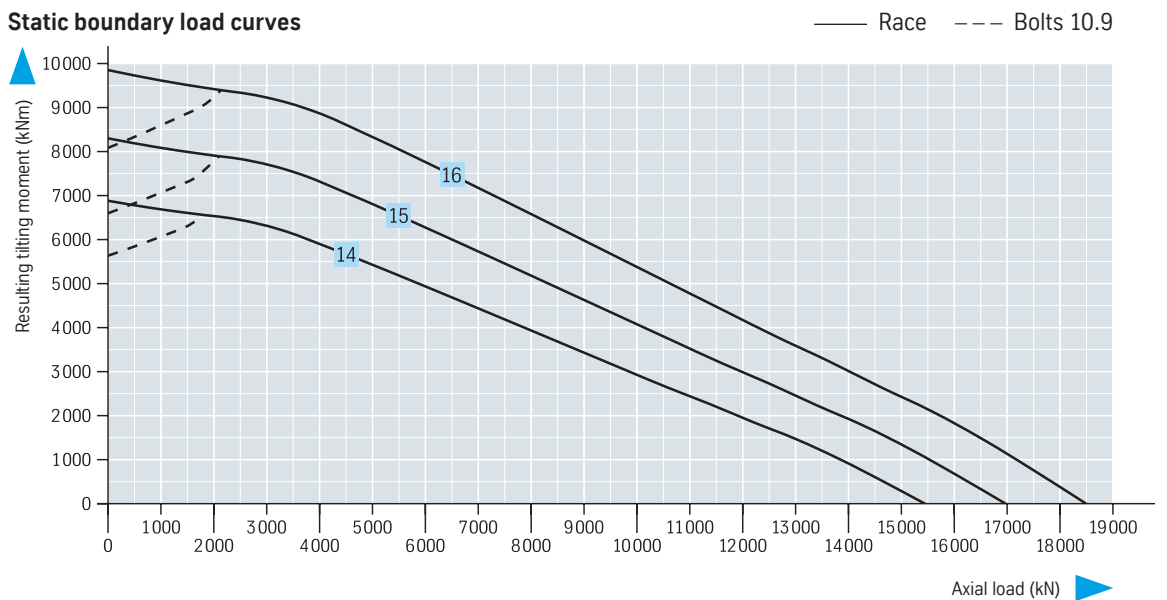

Attachment					Gearing									Miscellaneous	
$\emptyset L_a$ mm	$\emptyset L_l$ mm	n	$\emptyset B$ mm	M mm	d mm	m mm	z	x · m mm	k · m mm	b _{min} mm	$\emptyset Z_u$ mm	X1 kN	X2 kN	kg	n ₁
2113	1899	60	36	33	2212	14	158	7	-1,4	138	2185	121,33 168,00	242,67 336,00	1220	10
2309	2095	64	36	33	2408	14	172	7	-1,4	138	2381	121,33 168,00	242,67 336,00	1342	8
2505	2291	72	36	33	2604	14	186	7	-1,4	138	2577	121,33 168,00	242,67 336,00	1455	9

Diameter tolerances

Machined diameters with untoleranced drawing dimensions have the following tolerances:

- ≤ 2000 mm ± 3,5 mm
- ≤ 4000 mm ± 5,0 mm

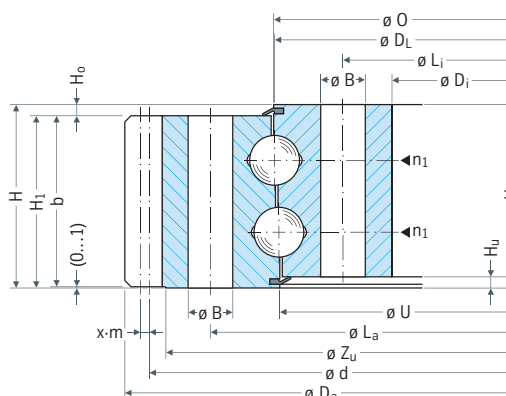

Utilization period curves – 30 000 revolutions

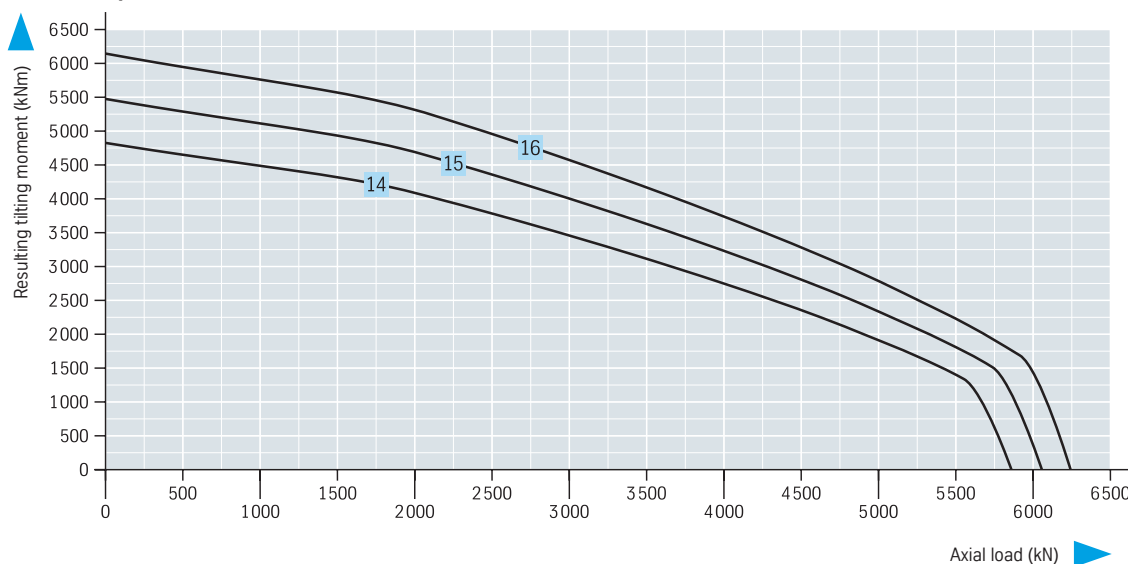

Bearing selection series 09

Series 09 Double-row four-point bearing

Bearing with internal gearing		Geometry									
Drawing number		$\varnothing D_L$ mm	$\varnothing D_a$ mm	$\varnothing D_i$ mm	H mm	$\varnothing O$ mm	$\varnothing U$ mm	H ₁ mm	H ₂ mm	H _u mm	H _o mm
14	092.40.2003.990.11.1502 092.40.2003.991.41.1502	2003	2192	1750	148	2001	2011	139	139	9	9
15	092.40.2199.990.11.1502 092.40.2199.991.41.1502	2199	2388	1946	148	2197	2207	139	139	9	9
16	092.40.2395.990.11.1502 092.40.2395.991.41.1502	2395	2584	2142	148	2393	2403	139	139	9	9

Ring gear normalised
 Ring gear annealed

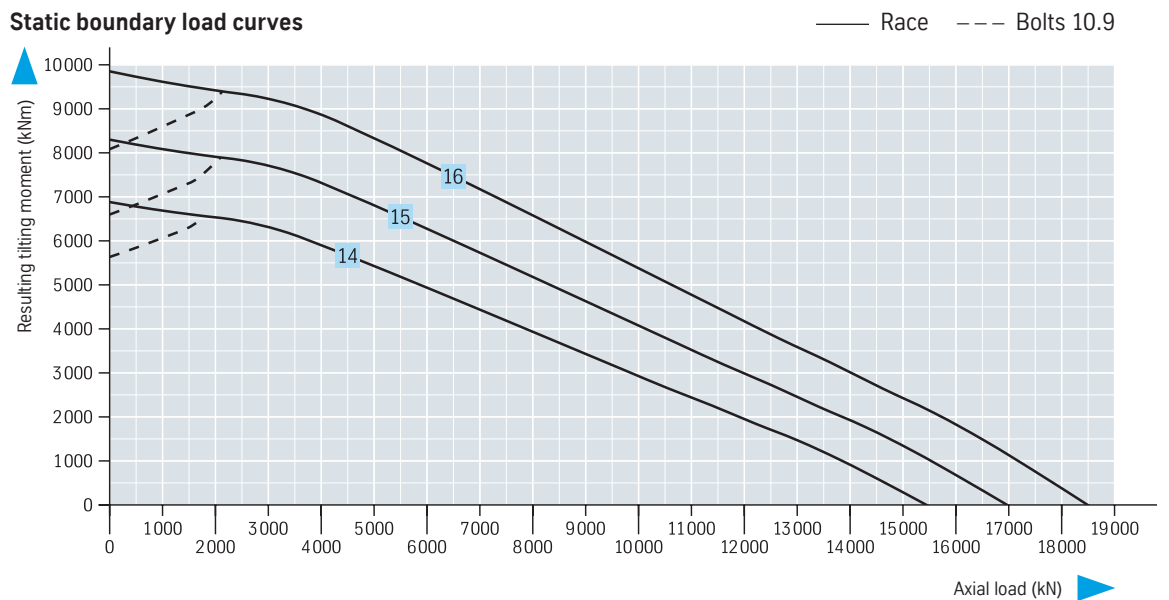

Attachment					Gearing									Miscellaneous	
$\varnothing L_a$ mm	$\varnothing L_l$ mm	n	$\varnothing B$ mm	M mm	d mm	m mm	z	x · m mm	k · m mm	b _{min} mm	$\varnothing Z_u$ mm	X1 kN	X2 kN	kg	n ₁
2113	1899	60	36	33	1764	14	126	- 7	0	138	1819	121,33 168,00	242,67 336,00	1221	10
2309	2095	64	36	33	1960	14	140	- 7	0	138	2015	121,33 168,00	242,67 336,00	1359	8
2505	2291	72	36	33	2156	14	154	- 7	0	138	2211	121,33 168,00	242,67 336,00	1480	9

Diameter tolerances

Machined diameters with untoleranced drawing dimensions have the following tolerances:

- ≤ 2000 mm ± 3,5 mm
- ≤ 4000 mm ± 5,0 mm

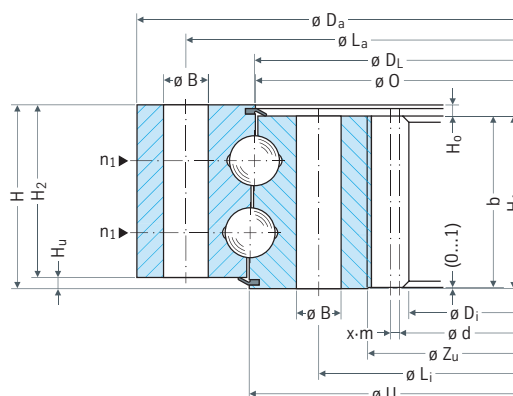

Utilization period curves – 30 000 revolutions

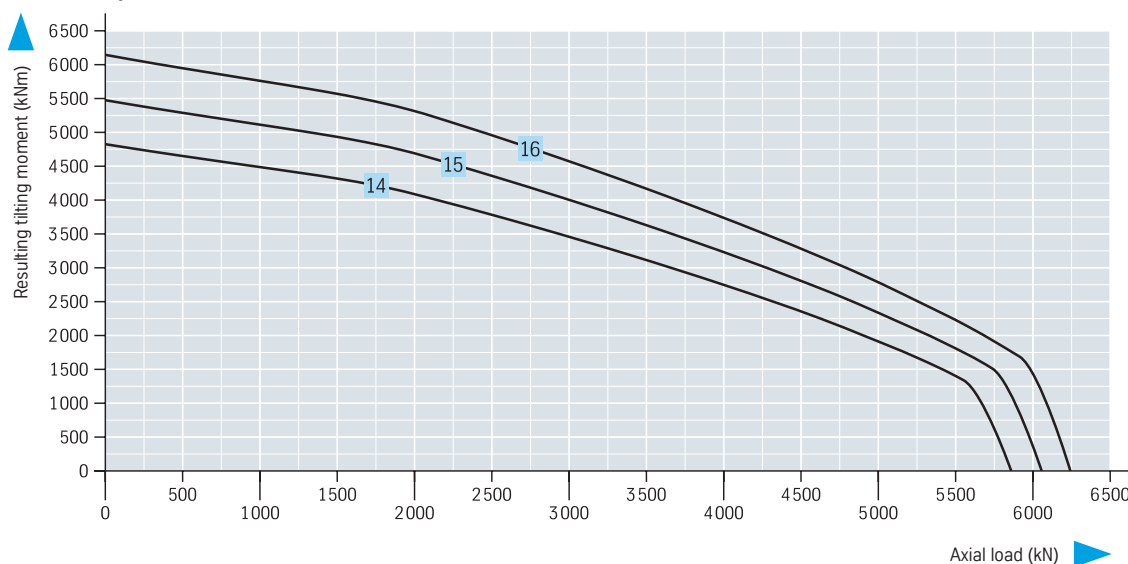

Bearing selection series 09

Series 09 Double-row four-point bearing

Bearing with external gearing		Geometry									
Drawing number		$\varnothing D_L$ mm	$\varnothing D_a$ mm	$\varnothing D_I$ mm	H mm	$\varnothing O$ mm	$\varnothing U$ mm	H ₁ mm	H ₂ mm	H _U mm	H _O mm
17	091.50.2266.990.41.1502	2266	2552,4	2064	188	2277	2264	179	179	9	9
18	091.50.2446.990.41.1502	2446	2732,4	2244	188	2457	2444	179	179	9	9
19	091.50.2644.990.41.1502	2644	2930,4	2442	188	2655	2642	179	179	9	9
20	091.50.2842.990.41.1502	2842	3128,4	2640	188	2853	2840	179	179	9	9

Ring gear normalised

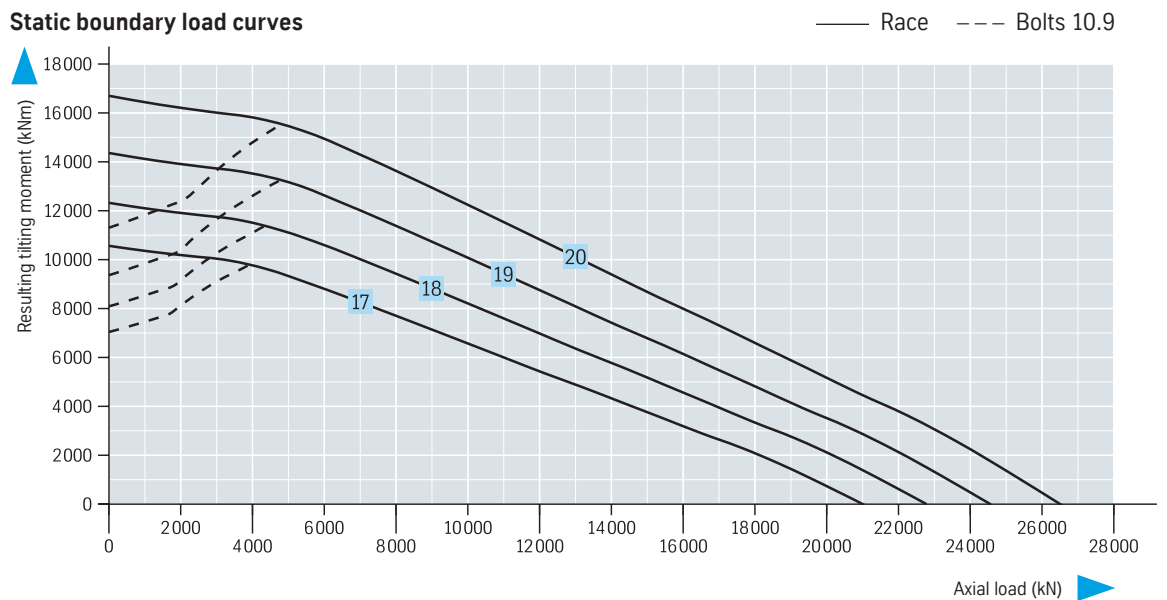

Attachment					Gearing									Miscellaneous	
$\varnothing L_a$ mm	$\varnothing L_l$ mm	n	$\varnothing B$ mm	M mm	d mm	m mm	z	$x \cdot m$ mm	$k \cdot m$ mm	b_{min} mm	$\varnothing Z_u$ mm	X1 kN	X2 kN	kg	n_1
2391	2150	56	39	36	2502	18	139	9	-1,8	178	2469	278,61	557,22	2020	8
2571	2330	60	39	36	2682	18	149	9	-1,8	178	2649	278,61	557,22	2179	10
2769	2528	64	39	36	2880	18	160	9	-1,8	178	2847	278,61	557,22	2357	8
2967	2726	72	39	36	3078	18	171	9	-1,8	178	3045	278,61	557,22	2519	9

Diameter tolerances

Machined diameters with untoleranced drawing dimensions have the following tolerances:

$\leq 4000\text{mm} \pm 5,0\text{mm}$

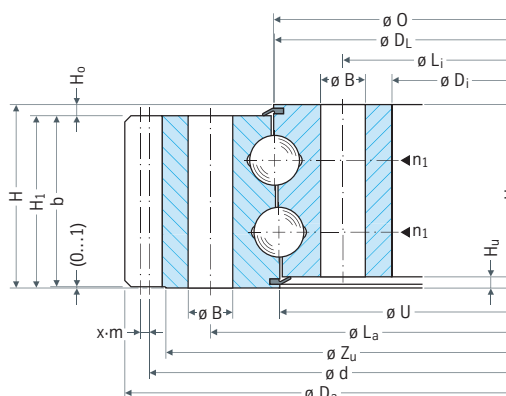

Utilization period curves – 30 000 revolutions

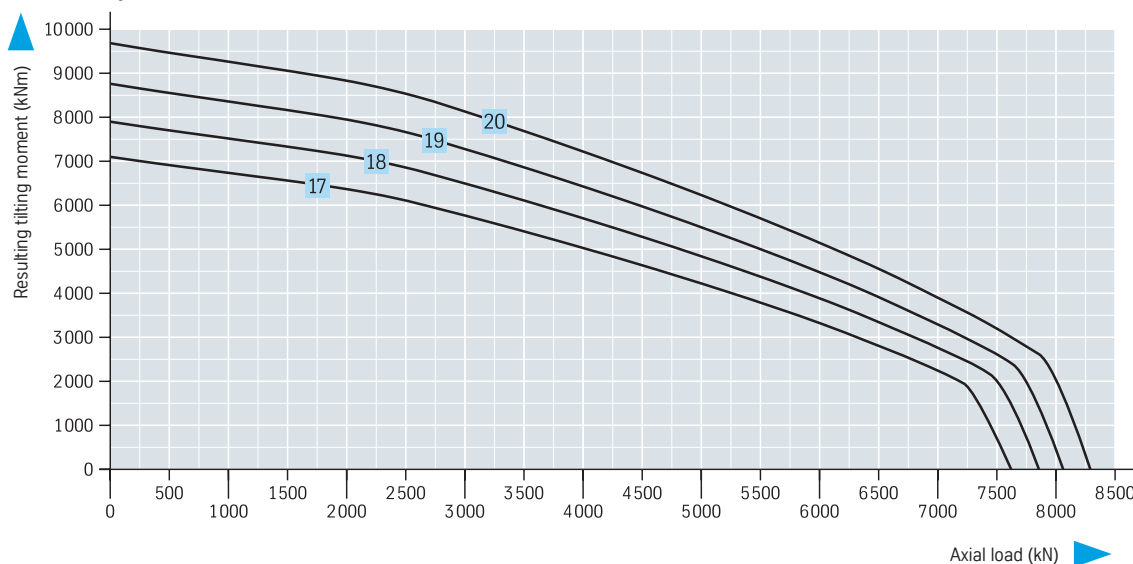

Bearing selection series 09

Series 09 Double-row four-point bearing

Bearing with internal gearing		Geometry									
Drawing number		$\varnothing D_L$ mm	$\varnothing D_a$ mm	$\varnothing D_i$ mm	H mm	$\varnothing O$ mm	$\varnothing U$ mm	H ₁ mm	H ₂ mm	H _u mm	H _o mm
17	092.50.2266.990.41.1502	2266	2477	1980	188	2264	2277	179	179	9	9
18	092.50.2446.990.41.1502	2446	2657	2160	188	2444	2457	179	179	9	9
19	092.50.2644.990.41.1502	2644	2855	2358	188	2642	2655	179	179	9	9
20	092.50.2842.990.41.1502	2842	3053	2556	188	2840	2853	179	179	9	9

Ring gear normalised

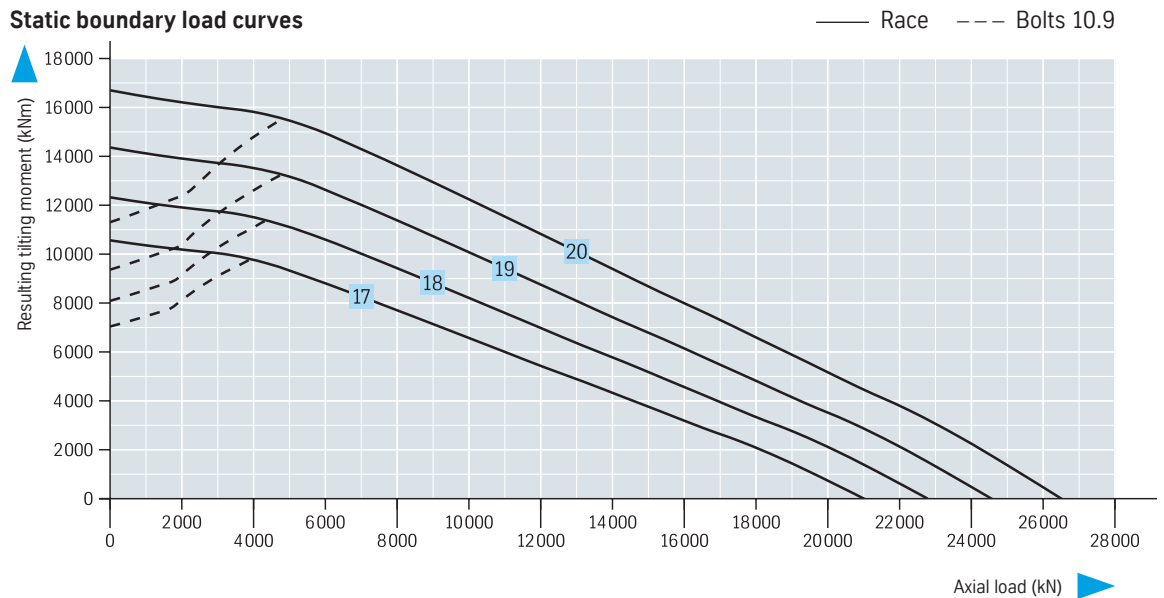

Attachment					Gearing									Miscellaneous	
$\emptyset L_a$ mm	$\emptyset L_l$ mm	n	$\emptyset B$ mm	M mm	d mm	m mm	z	x · m mm	k · m mm	b_{min} mm	$\emptyset Z_u$ mm	X1 kN	X2 kN	kg	n_1
2391	2150	56	39	36	1998	18	111	-9	0	178	2067	278,61	557,22	2000	8
2571	2330	60	39	36	2178	18	121	-9	0	178	2247	278,61	557,22	2161	10
2769	2528	64	39	36	2376	18	132	-9	0	178	2445	278,61	557,22	2340	8
2967	2726	72	39	36	2574	18	143	-9	0	178	2643	278,61	557,22	2505	9

Diameter tolerances

Machined diameters with untoleranced drawing dimensions have the following tolerances:

- ≤ 2000 mm ± 3,5 mm
- ≤ 4000 mm ± 5,0 mm

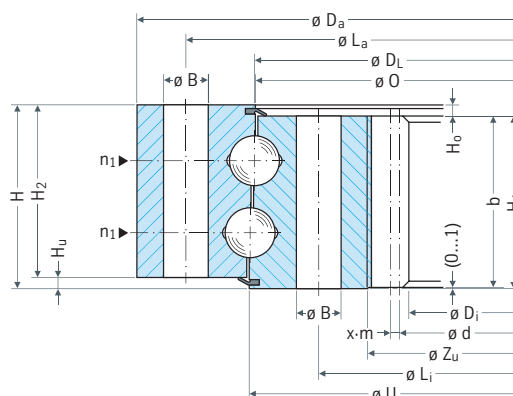

Utilization period curves – 30 000 revolutions

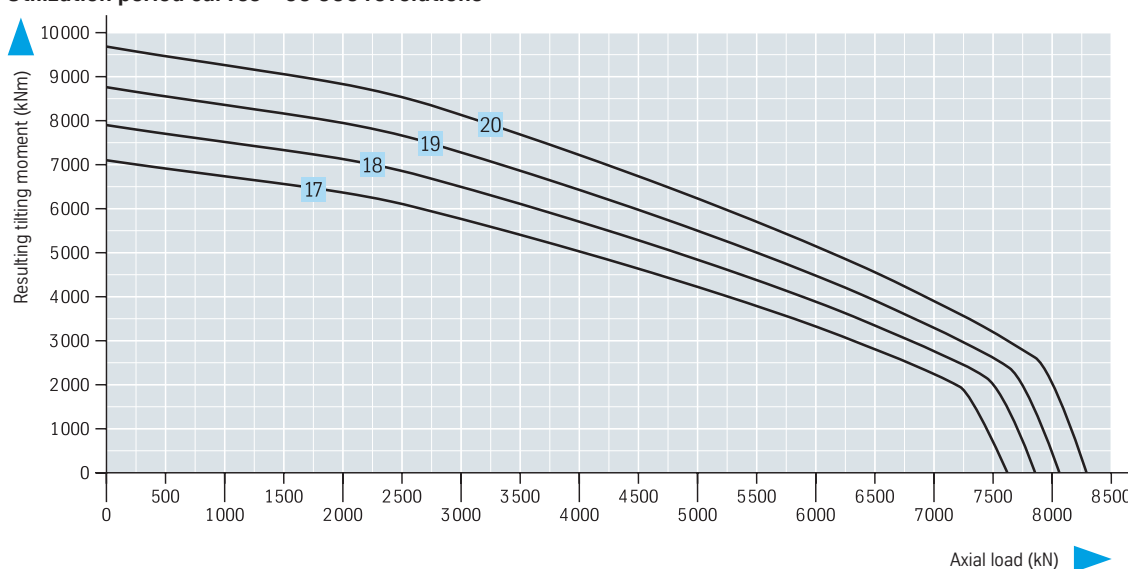

Bearing selection series 09

Series 19

Three-row roller bearing

Bearing with external gearing		Geometry									
Drawing number		$\varnothing D_L$ mm	$\varnothing D_a$ mm	$\varnothing D_I$ mm	H mm	$\varnothing O$ mm	$\varnothing U$ mm	H ₁ mm	H ₂ mm	H _U mm	H _o mm
1	191.20.1250.990.41.1502	1250	1461,6	1103	132	1280	1282	106	123	9	26
2	191.20.1400.990.41.1502	1400	1635,2	1253	132	1430	1432	106	123	9	26
3	191.20.1600.990.41.1502	1600	1831,2	1453	132	1630	1632	106	123	9	26
4	191.20.1800.990.41.1502	1800	2044,8	1653	132	1830	1832	106	123	9	26
5	191.20.2000.990.41.1502	2000	2236,8	1853	132	2030	2032	106	123	9	26

Ring gear annealed

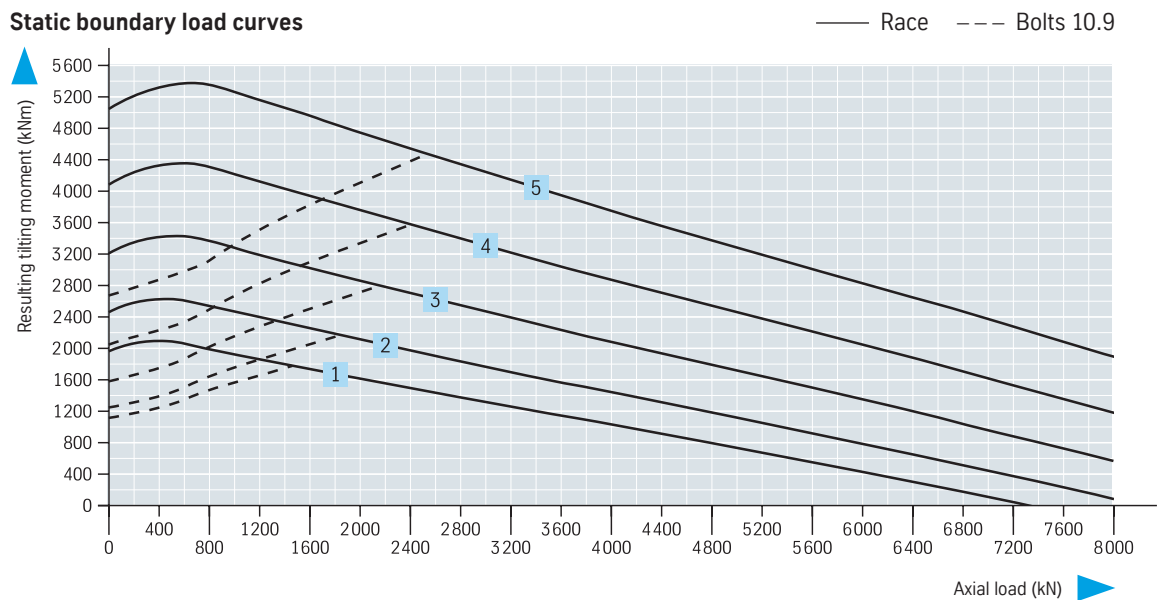

Attachment					Gearing								Miscellaneous	
$\emptyset L_a$ mm	$\emptyset L_l$ mm	n	$\emptyset B$ mm	M mm	d mm	m mm	z	x · m mm	k · m mm	b_{min} mm	X1 kN	X2 kN	kg	n_1
1355	1155	36	26	24	1428	12	119	+ 6,0	- 1,2	105	115,65	231,30	542	3
1505	1305	36	26	24	1596	14	114	+ 7,0	- 1,4	105	134,93	269,86	646	3
1705	1505	40	26	24	1792	14	128	+ 7,0	- 1,4	105	134,93	269,86	731	4
1905	1705	46	26	24	2000	16	125	+ 8,0	- 1,6	105	154,20	308,41	844	5
2105	1905	54	26	24	2192	16	137	+ 8,0	- 1,6	105	154,20	308,41	912	5

Diameter tolerances

Machined diameters with untoleranced drawing dimensions have the following tolerances:

- ≤ 2000 mm ± 3,5 mm
- ≤ 4000 mm ± 5,0 mm

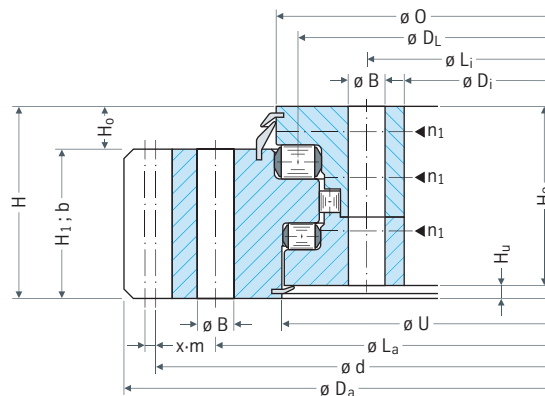

Utilization period curves – 30 000 revolutions

drawing position = mounting position

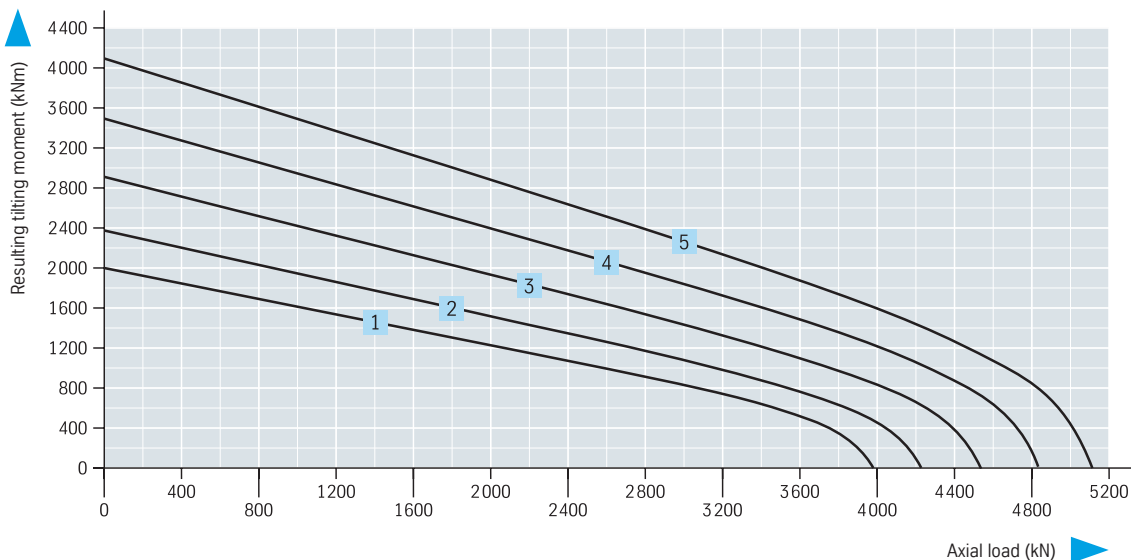

Series 19 Three-row roller bearing

Bearing with internal gearing		Geometry									
Drawing number		$\varnothing D_L$ mm	$\varnothing D_a$ mm	$\varnothing D_i$ mm	H mm	$\varnothing O$ mm	$\varnothing U$ mm	H ₁ mm	H ₂ mm	H _u mm	H _o mm
1	192.20.1250.990.41.1502	1250	1397	1032	132	1219	1218	106	123	9	26
2	192.20.1400.990.41.1502	1400	1547	1162	132	1369	1368	106	123	9	26
3	192.20.1600.990.41.1502	1600	1747	1372	132	1569	1568	106	123	9	26
4	192.20.1800.990.41.1502	1800	1947	1552	132	1769	1768	106	123	9	26
5	192.20.2000.990.41.1502	2000	2147	1760	132	1969	1968	106	123	9	26

Ring gear annealed

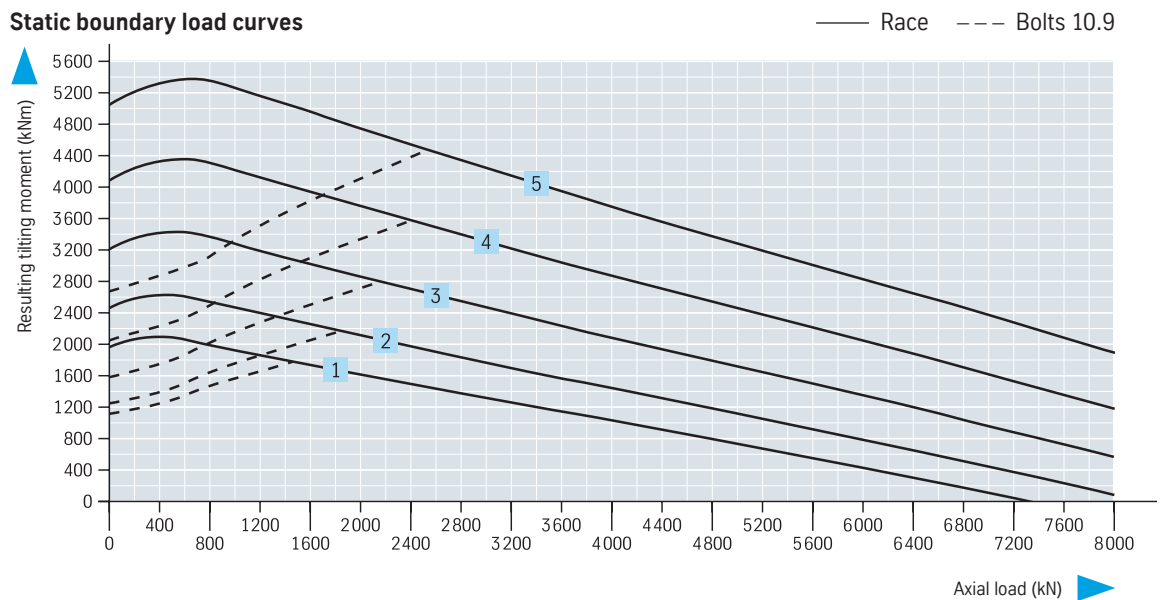

Attachment					Gearing							Miscellaneous	
$\varnothing L_a$ mm	$\varnothing L_l$ mm	n	$\varnothing B$ mm	M mm	d mm	m mm	z	x · m mm	b_{min} mm	X1 kN	X2 kN	kg	n_1
1345	1145	36	26	24	1044	12	87	-6,0	105	115,65	231,30	539	3
1495	1295	36	26	24	1176	14	84	-7,0	105	134,93	269,86	630	3
1695	1495	40	26	24	1386	14	99	-7,0	105	134,93	269,86	705	4
1895	1695	46	26	24	1568	16	98	-8,0	105	154,20	308,41	829	5
2095	1895	54	26	24	1776	16	111	-8,0	105	154,20	308,41	902	5

Diameter tolerances

Machined diameters with untoleranced drawing dimensions have the following tolerances:

- ≤ 2000 mm ± 3,5 mm
- ≤ 4000 mm ± 5,0 mm

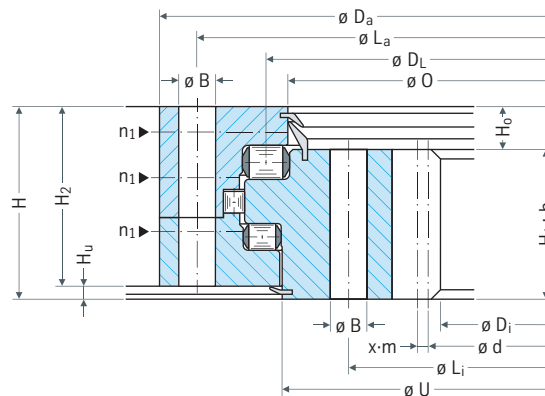

Utilization period curves – 30 000 revolutions

drawing position = mounting position

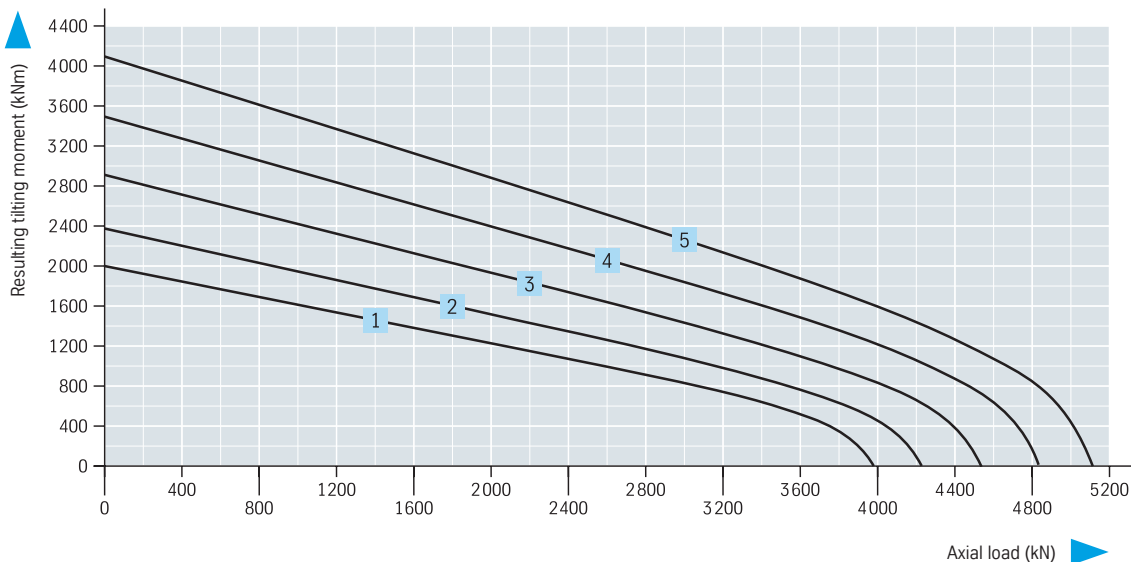

Series 19 Three-row roller bearing

Bearing with external gearing		Geometry									
Drawing number		$\varnothing D_L$ mm	$\varnothing D_a$ mm	$\varnothing D_i$ mm	H mm	$\varnothing O$ mm	$\varnothing U$ mm	H ₁ mm	H ₂ mm	H _u mm	H _o mm
6	191.25.1800.990.41.1502	1800	2076,8	1619	147	1836	1826	117	138	9	30
7	191.25.2000.990.41.1502	2000	2268,8	1819	147	2036	2026	117	138	9	30
8	191.25.2240.990.41.1502	2240	2516,4	2059	147	2276	2266	117	138	9	30
9	191.25.2500.990.41.1502	2500	2786,4	2319	147	2536	2526	117	138	9	30
10	191.25.2800.990.41.1502	2800	3096,4	2619	147	2836	2826	117	138	9	30

Ring gear annealed

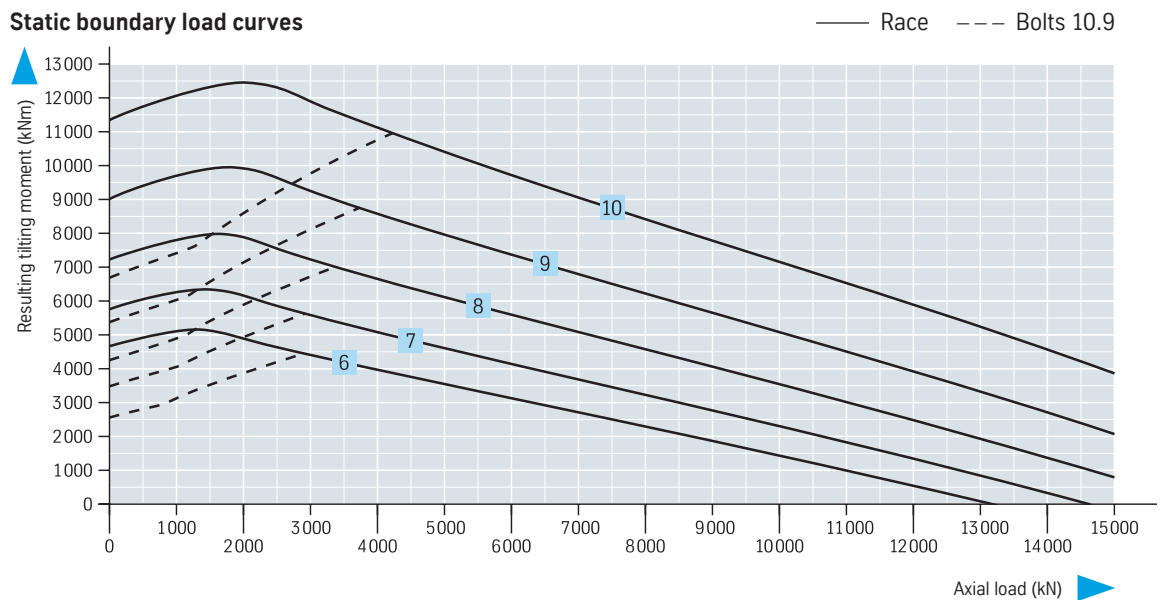

Attachment					Gearing								Miscellaneous	
$\emptyset L_a$ mm	$\emptyset L_l$ mm	n	$\emptyset B$ mm	M mm	d mm	m mm	z	x · m mm	k · m mm	b _{min} mm	X1 kN	X2 kN	kg	n ₁
1925	1685	36	33	30	2032	16	127	+ 8,0	- 1,6	116	161,39	322,78	1126	6
2125	1885	44	33	30	2224	16	139	+ 8,0	- 1,6	116	161,39	322,78	1216	7
2366	2125	48	33	30	2466	18	137	+ 9,0	- 1,8	116	181,57	363,13	1378	8
2625	2385	54	33	30	2736	18	152	+ 9,0	- 1,8	116	181,57	363,13	1567	6
2925	2685	60	33	30	3040	20	152	+ 10,0	- 2,0	116	201,74	403,48	1785	10

Diameter tolerances

Machined diameters with untoleranced drawing dimensions have the following tolerances:

- ≤ 2000 mm ± 3,5 mm
- ≤ 4000 mm ± 5,0 mm

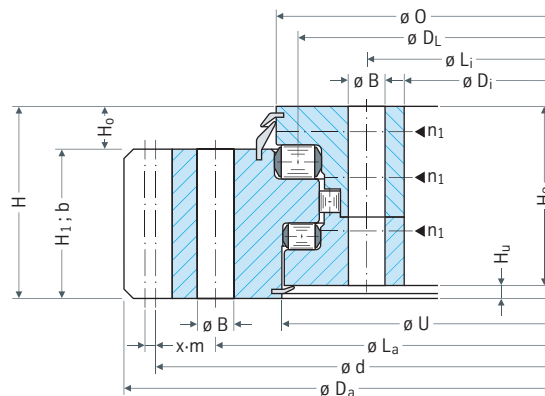

Utilization period curves – 30 000 revolutions

drawing position = mounting position

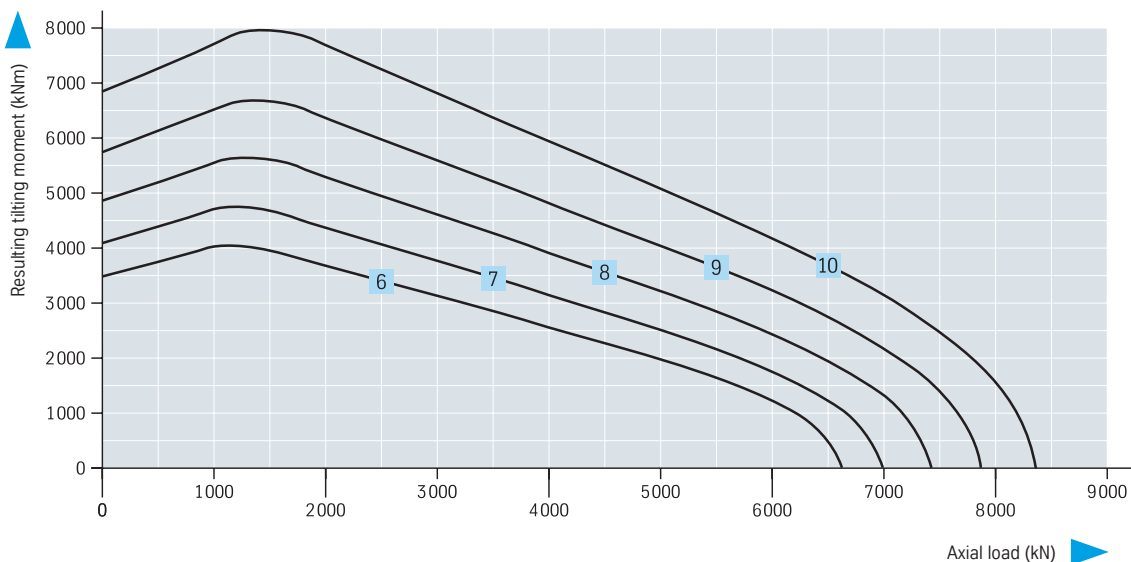

Series 19 Three-row roller bearing

Bearing with internal gearing		Geometry									
Drawing number		$\varnothing D_L$ mm	$\varnothing D_a$ mm	$\varnothing D_i$ mm	H mm	$\varnothing O$ mm	$\varnothing U$ mm	H ₁ mm	H ₂ mm	H _u mm	H _o mm
6	192.25.1800.990.41.1502	1800	1981	1520	147	1763	1774	117	138	9	30
7	192.25.2000.990.41.1502	2000	2181	1728	147	1963	1974	117	138	9	30
8	192.25.2240.990.41.1502	2240	2421	1944	147	2203	2214	117	138	9	30
9	192.25.2500.990.41.1502	2500	2681	2214	147	2463	2474	117	138	9	30
10	192.25.2800.990.41.1502	2800	2981	2500	147	2763	2774	117	138	9	30

Ring gear annealed

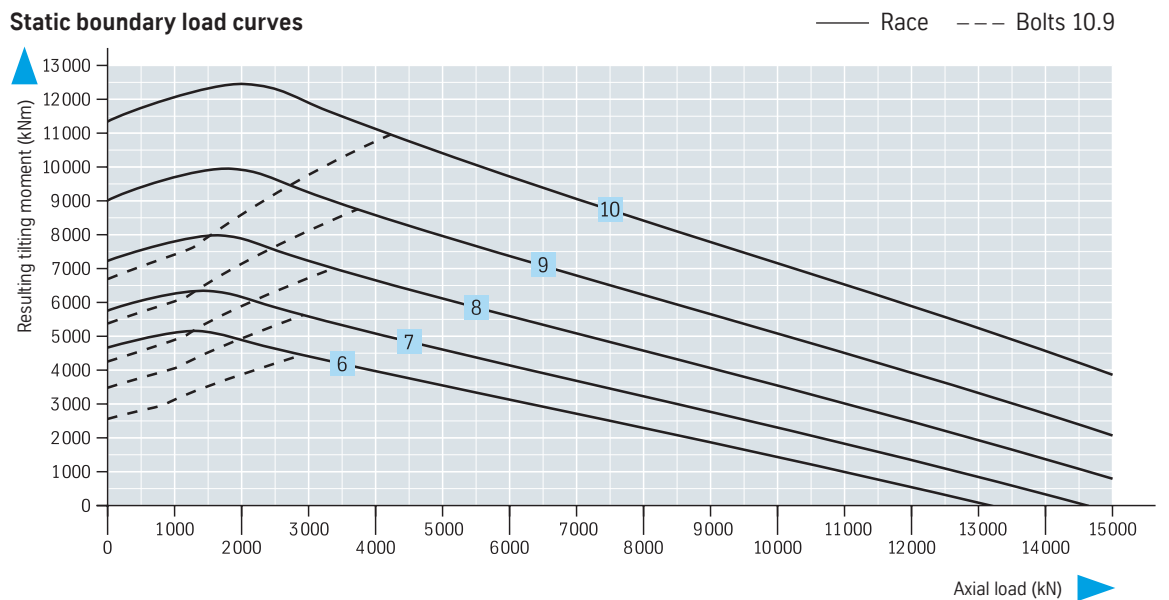

Attachment					Gearing								Miscellaneous	
$\varnothing L_a$ mm	$\varnothing L_l$ mm	n	$\varnothing B$ mm	M mm	d mm	m mm	z	x · m mm	b_{min} mm	X1 kN	X2 kN	kg	n_1	
1915	1675	36	33	30	1536	16	96	-8,0	116	161,39	322,78	1101	6	
2115	1875	44	33	30	1744	16	109	-8,0	116	161,39	322,78	1202	7	
2355	2115	48	33	30	1962	18	109	-9,0	116	181,57	363,13	1406	8	
2615	2375	54	33	30	2232	18	124	-9,0	116	181,57	363,13	1545	6	
2915	2675	60	33	30	2520	20	126	-10,0	116	201,74	403,48	1767	10	

Diameter tolerances

Machined diameters with untoleranced drawing dimensions have the following tolerances:

- ≤ 2000 mm ± 3,5 mm
- ≤ 4000 mm ± 5,0 mm

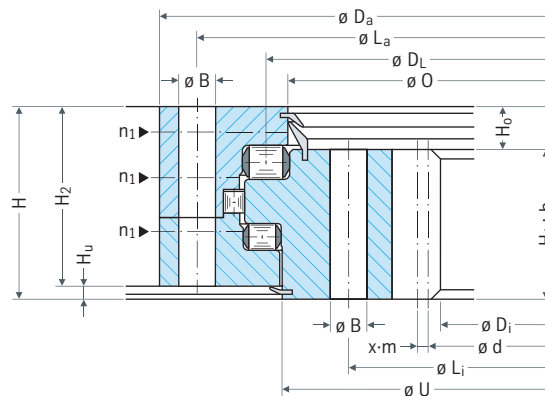

Utilization period curves – 30 000 revolutions

drawing position = mounting position

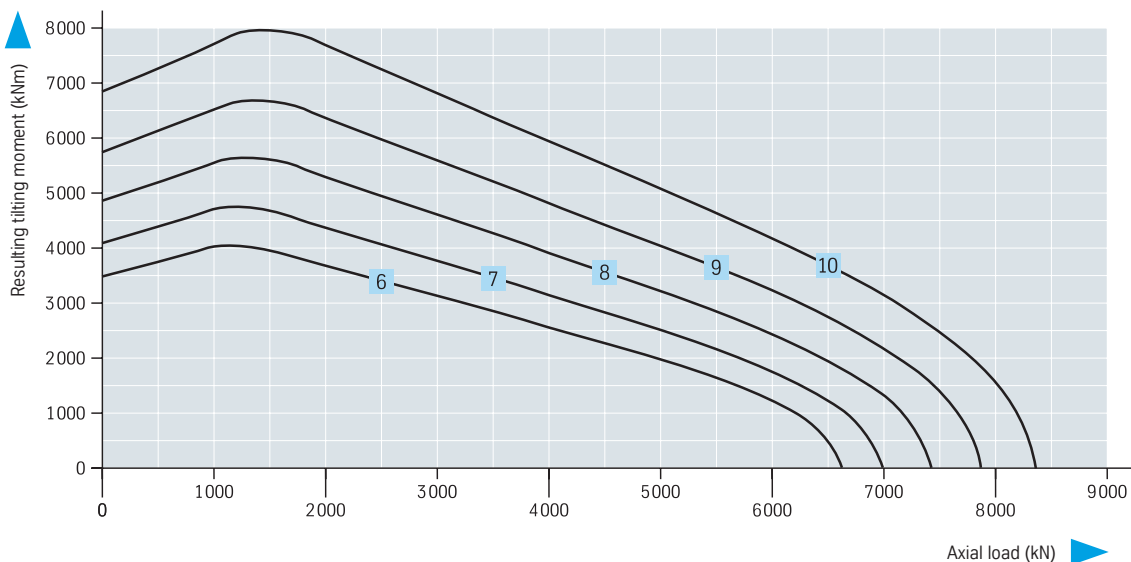

Series 19 Three-row roller bearing

Bearing with external gearing		Geometry									
		$\varnothing D_L$ mm	$\varnothing D_a$ mm	$\varnothing D_i$ mm	H mm	$\varnothing O$ mm	$\varnothing U$ mm	H ₁ mm	H ₂ mm	H _u mm	H _o mm
11	191.32.2240.990.41.1502	2240	2552,4	2022	181	2281	2270	139	172	9	42
12	191.32.2500.990.41.1502	2500	2822,4	2282	181	2541	2530	139	172	9	42
13	191.32.2800.990.41.1502	2800	3136,4	2582	181	2841	2830	139	172	9	42
14	191.32.3150.990.41.1502	3150	3476,4	2932	181	3191	3180	139	172	9	42
15	191.32.3550.990.41.1502	3550	3889,6	3332	181	3591	3580	139	172	9	42
16	191.32.4000.990.41.1502	4000	4351,6	3782	181	4041	4030	139	172	9	42

Ring gear annealed

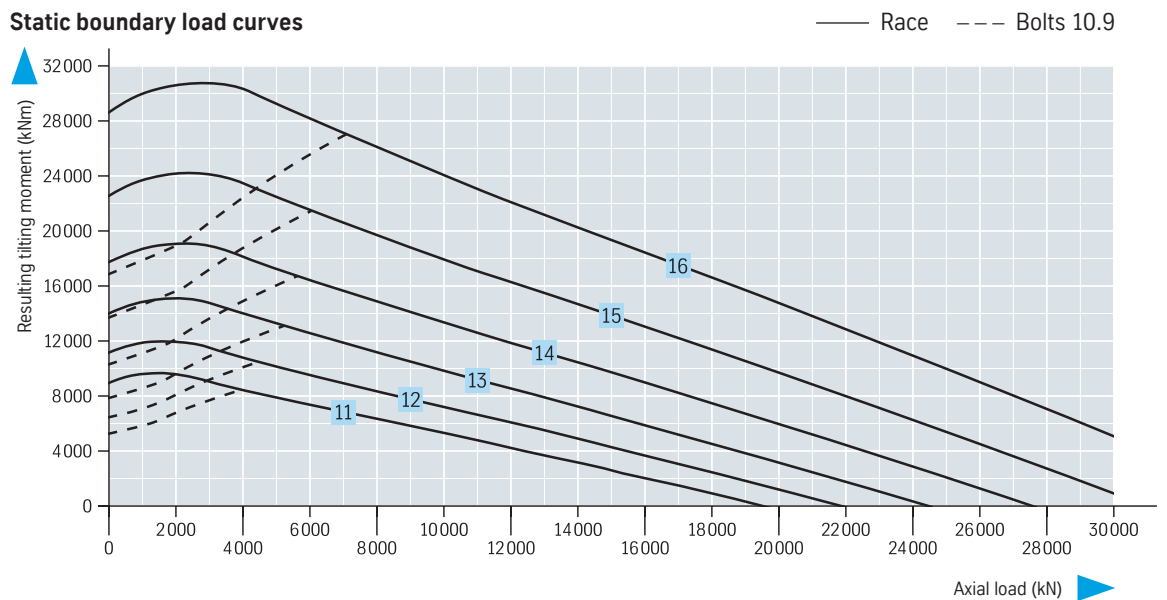

Attachment					Gearing								Miscellaneous	
$\varnothing L_a$ mm	$\varnothing L_l$ mm	n	$\varnothing B$ mm	M mm	d mm	m mm	z	x · m mm	k · m mm	b _{min} mm	X1 kN	X2 kN	kg	n ₁
2395	2100	40	39	36	2502	18	139	+ 9,0	- 1,8	138	216	432	1975	8
2655	2360	44	39	36	2772	18	154	+ 9,0	- 1,8	138	216	432	2260	7
2955	2660	48	39	36	3080	20	154	+ 10,0	- 2,0	138	240	480	2576	8
3305	3010	56	39	36	3420	20	171	+ 10,0	- 2,0	138	240	480	2828	7
3705	3410	66	39	36	3828	22	174	+ 11,0	- 2,2	138	264	528	3249	8
4155	3860	72	39	36	4290	22	195	+ 11,0	- 2,2	138	264	528	3752	9

Diameter tolerances

Machined diameters with untoleranced drawing dimensions have the following tolerances:

- ≤ 4000 mm ± 5,0 mm
- ≤ 6300 mm ± 7,0 mm

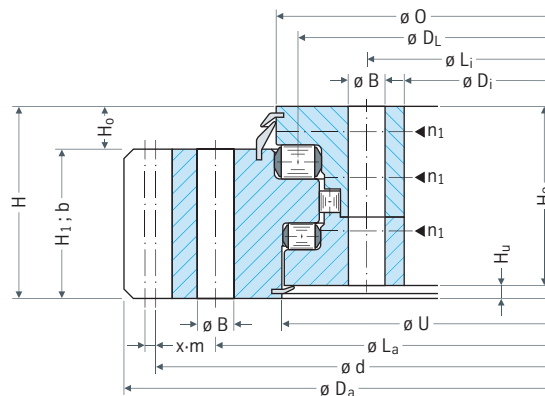

Utilization period curves – 30 000 revolutions

drawing position = mounting position

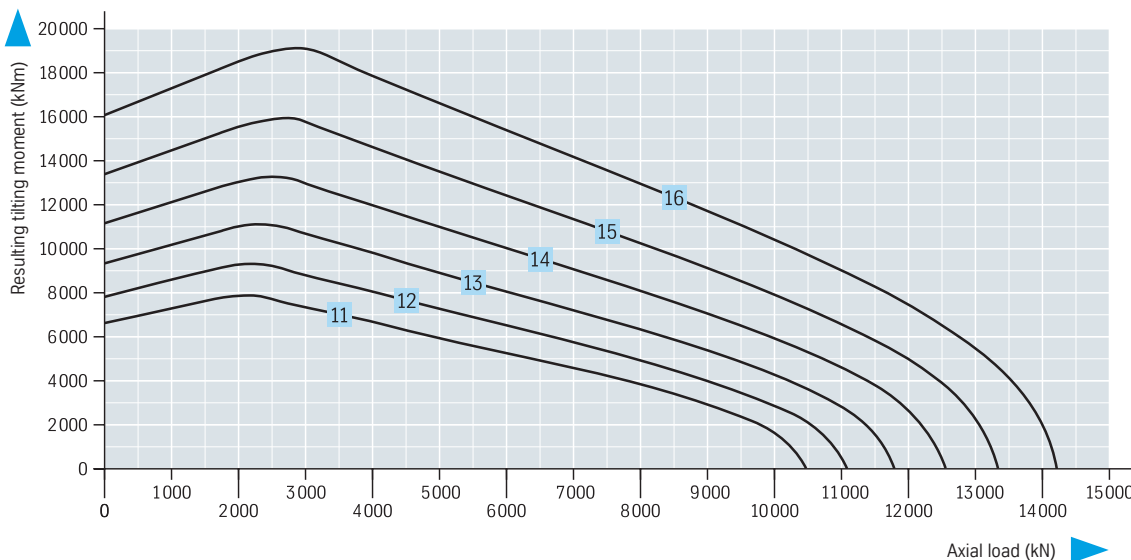

Series 19 Three-row roller bearing

Bearing with internal gearing		Geometry									
Drawing number		$\varnothing D_L$ mm	$\varnothing D_a$ mm	$\varnothing D_i$ mm	H mm	$\varnothing O$ mm	$\varnothing U$ mm	H ₁ mm	H ₂ mm	H _u mm	H _o mm
11	192.32.2240.990.41.1502	2240	2458	1908	181	2199	2210	139	172	9	42
12	192.32.2500.990.41.1502	2500	2718	2178	181	2459	2470	139	172	9	42
13	192.32.2800.990.41.1502	2800	3018	2460	181	2759	2770	139	172	9	42
14	192.32.3150.990.41.1502	3150	3368	2820	181	3109	3120	139	172	9	42
15	192.32.3550.990.41.1502	3550	3768	3190	181	3509	3520	139	172	9	42
16	192.32.4000.990.41.1502	4000	4218	3652	181	3959	3970	139	172	9	42

Ring gear annealed

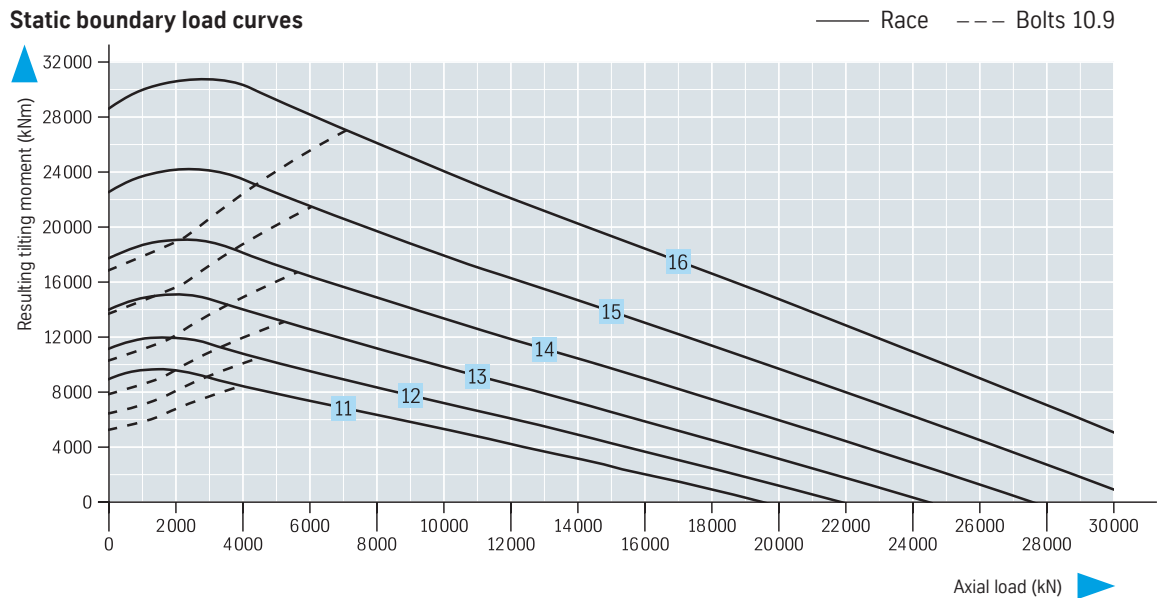

Attachment					Gearing								Miscellaneous	
$\varnothing L_a$ mm	$\varnothing L_l$ mm	n	$\varnothing B$ mm	M mm	d mm	m mm	z	x · m mm	b_{min} mm	X1 kN	X2 kN	kg	n_1	
2380	2085	40	39	36	1926	18	107	- 9,0	138	216	432	2010	8	
2640	2345	44	39	36	2196	18	122	- 9,0	138	216	432	2210	7	
2940	2645	48	39	36	2480	20	124	- 10,0	138	240	480	2542	8	
3290	2995	56	39	36	2840	20	142	- 10,0	138	240	480	2807	7	
3690	3395	66	39	36	3212	22	146	- 11,0	138	264	528	3302	8	
4140	3845	72	39	36	3674	22	167	- 11,0	138	264	528	3664	9	

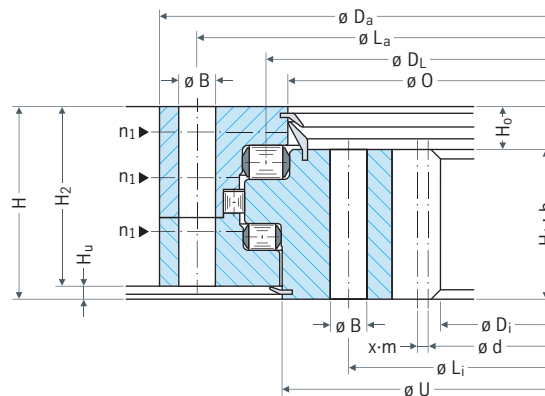

Diameter tolerances

Machined diameters with untoleranced drawing dimensions have the following tolerances:

- ≤ 2000 mm ± 3,5 mm
- ≤ 4000 mm ± 5,0 mm
- ≤ 6300 mm ± 7,0 mm

Utilization period curves – 30 000 revolutions

drawing position = mounting position

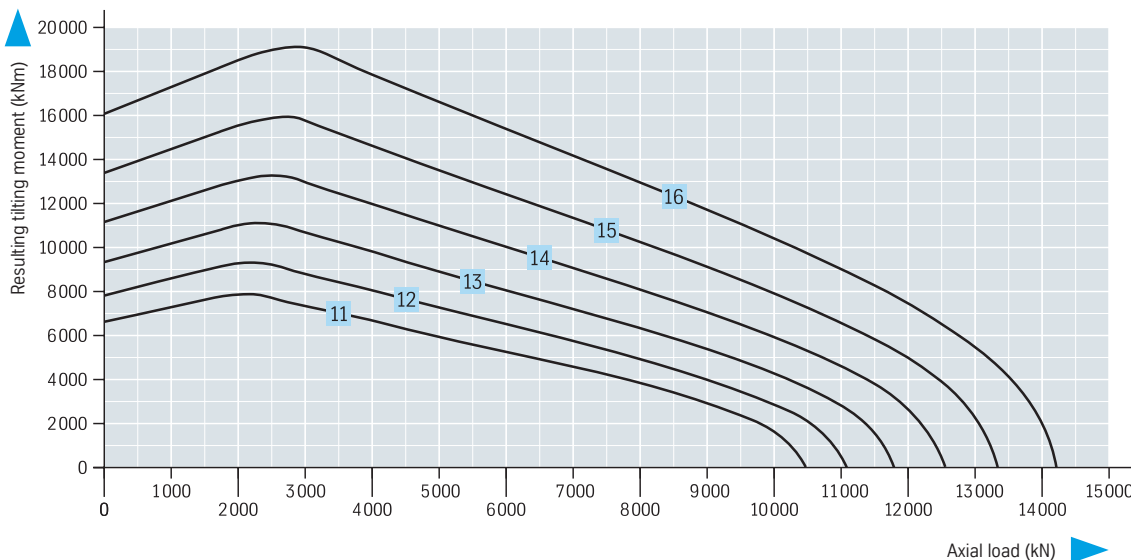

Series 19 Three-row roller bearing

Bearing with external gearing		Geometry									
Drawing number		$\varnothing D_L$ mm	$\varnothing D_a$ mm	$\varnothing D_i$ mm	H mm	$\varnothing O$ mm	$\varnothing U$ mm	H ₁ mm	H ₂ mm	H _u mm	H _o mm
17	191.40.2800.990.41.1502	2800	3136,0	2562	220	2850	2837	170	210	10	50
18	191.40.3150.990.41.1502	3150	3515,6	2912	220	3200	3187	170	210	10	50
19	191.40.3550.990.41.1502	3550	3911,6	3312	220	3600	3587	170	210	10	50
20	191.40.4000.990.41.1502	4000	4363,2	3762	220	4050	4037	170	210	10	50
21	191.40.4500.990.41.1502	4500	4867,2	4262	220	4550	4537	170	210	10	50

Ring gear annealed

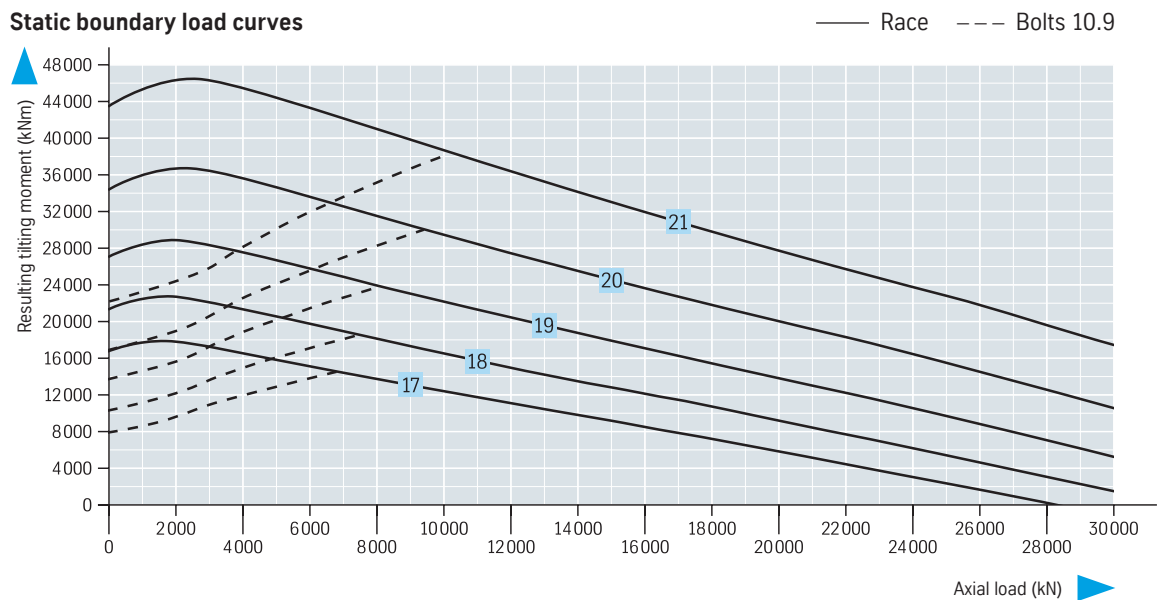

Attachment					Gearing								Miscellaneous	
$\emptyset L_a$ mm	$\emptyset L_l$ mm	n	$\emptyset B$ mm	M mm	d mm	m mm	z	x · m mm	k · m mm	b _{min} mm	X1 kN	X2 kN	kg	n ₁
2965	2640	48	39	36	3080	20	154	+ 10,0	- 2,0	169	293,91	587,83	3267	8
3315	2990	56	39	36	3454	22	157	+ 11,0	- 2,2	169	323,30	646,61	3812	7
3715	3390	66	39	36	3850	22	175	+ 11,0	- 2,2	169	323,30	646,61	4255	8
4165	3840	72	39	36	4296	24	179	+ 12,0	- 2,4	169	352,70	705,39	4805	9
4665	4340	84	39	36	4800	24	200	+ 12,0	- 2,4	169	352,70	705,39	5410	14

Diameter tolerances

Machined diameters with untoleranced drawing dimensions have the following tolerances:

- ≤ 4000 mm ± 5,0 mm
- ≤ 6300 mm ± 7,0 mm

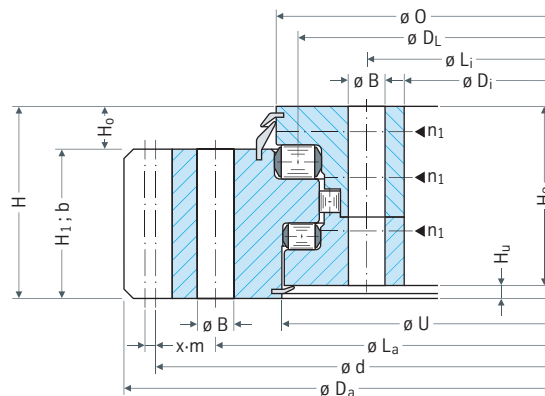

Utilization period curves – 30 000 revolutions

drawing position = mounting position

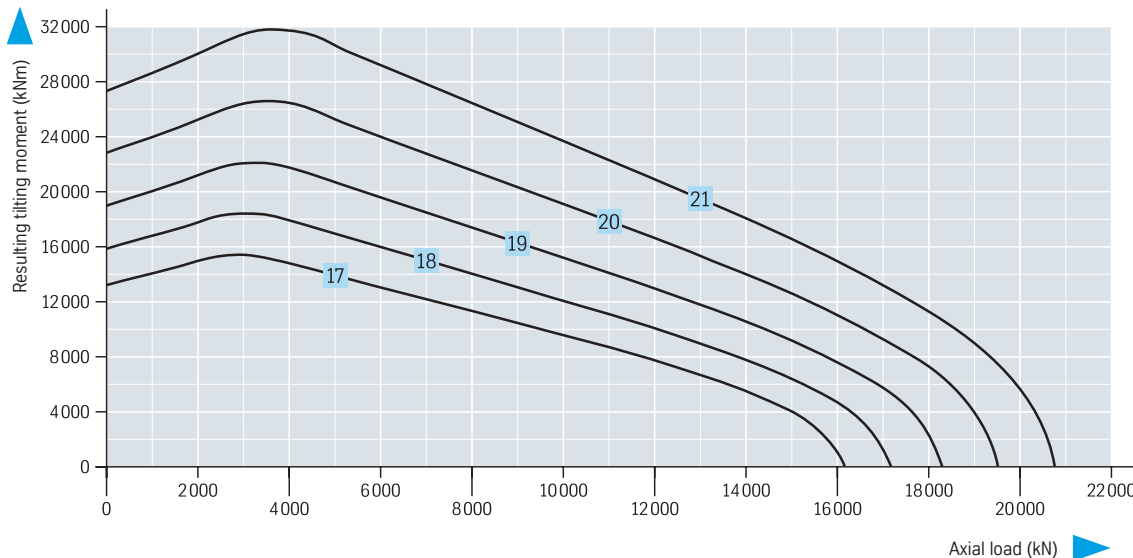

Series 19 Three-row roller bearing

Bearing with internal gearing		Geometry									
Drawing number		$\varnothing D_L$ mm	$\varnothing D_a$ mm	$\varnothing D_i$ mm	H mm	$\varnothing O$ mm	$\varnothing U$ mm	H ₁ mm	H ₂ mm	H _U mm	H _o mm
17	192.40.2800.990.41.1502	2800	3038	2460	220	2750	2763	170	210	10	50
18	192.40.3150.990.41.1502	3150	3388	2794	220	3100	3113	170	210	10	50
19	192.40.3550.990.41.1502	3550	3788	3190	220	3500	3513	170	210	10	50
20	192.40.4000.990.41.1502	4000	4238	3624	220	3950	3963	170	210	10	50
21	192.40.4500.990.41.1502	4500	4738	4128	220	4450	4463	170	210	10	50

Ring gear annealed

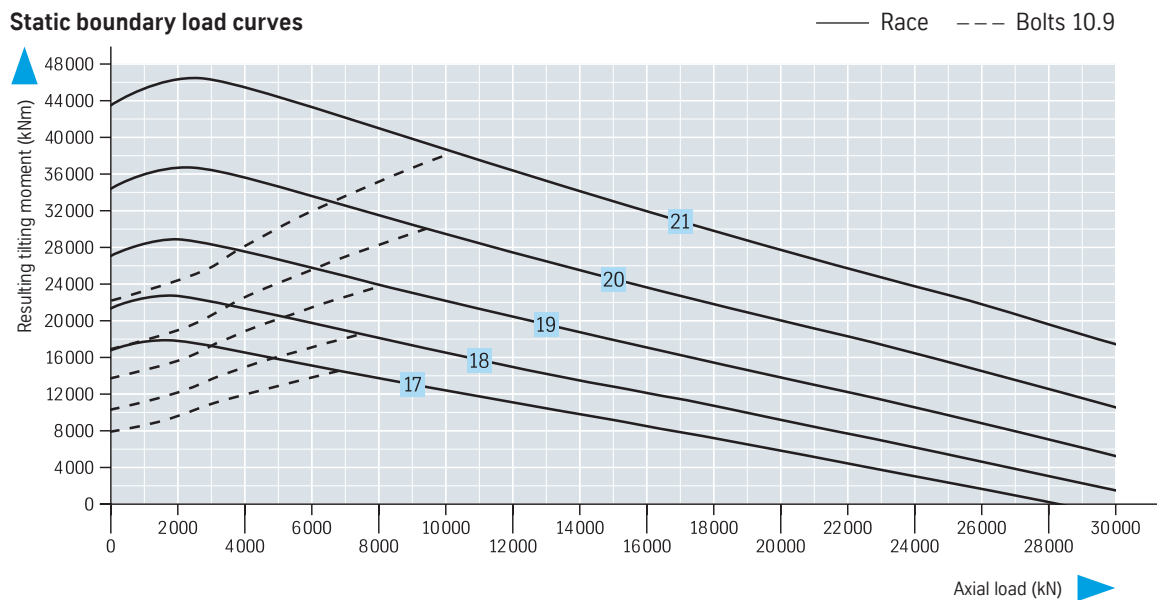

Attachment					Gearing								Miscellaneous	
$\varnothing L_a$ mm	$\varnothing L_l$ mm	n	$\varnothing B$ mm	M mm	d mm	m mm	z	x · m mm	b_{min} mm	X1 kN	X2 kN	kg	n_1	
2960	2635	48	39	36	2480	20	124	- 10,0	169	293,91	587,83	3213	8	
3310	2985	56	39	36	2816	22	128	- 11,0	169	323,30	646,61	3683	7	
3710	3385	66	39	36	3212	22	146	- 11,0	169	323,30	646,61	4171	8	
4160	3835	72	39	36	3648	24	152	- 12,0	169	352,70	705,39	4810	9	
4660	4335	84	39	36	4152	24	173	- 12,0	169	352,70	705,39	5367	14	

Diameter tolerances

Machined diameters with untoleranced drawing dimensions have the following tolerances:

- ≤ 4000 mm ± 5,0mm
- ≤ 6300 mm ± 7,0mm

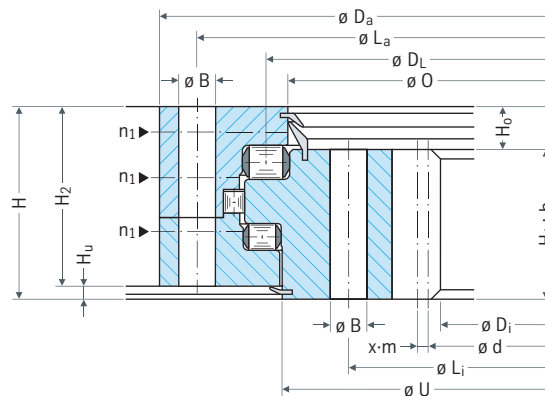

Utilization period curves – 30 000 revolutions

drawing position = mounting position

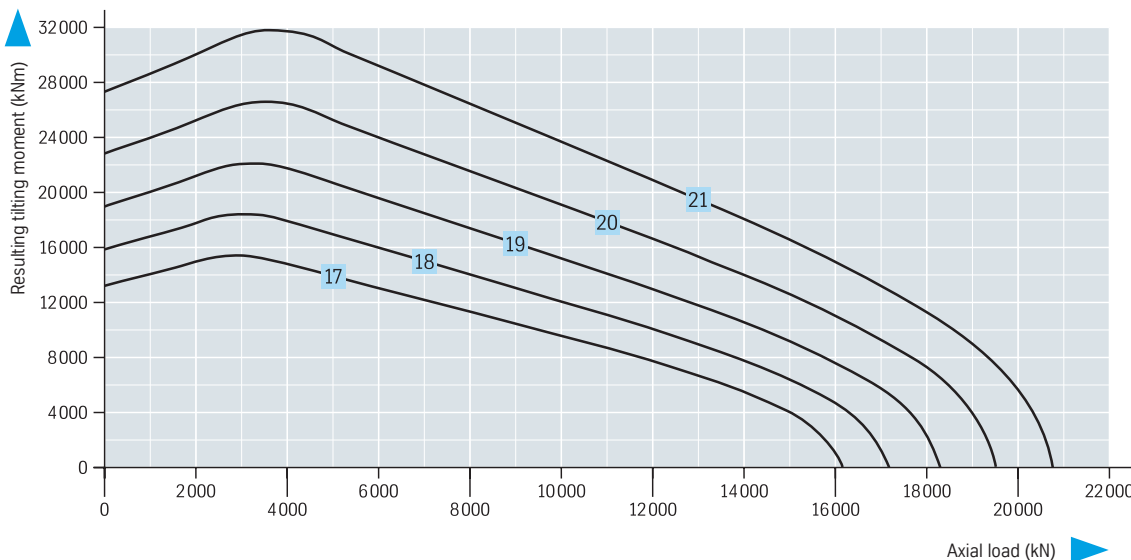

Series 19 Three-row roller bearing

Bearing with external gearing		Geometry									
Drawing number		$\varnothing D_L$ mm	$\varnothing D_a$ mm	$\varnothing D_i$ mm	H mm	$\varnothing O$ mm	$\varnothing U$ mm	H ₁ mm	H ₂ mm	H _U mm	H _o mm
22	191.50.3150.990.41.1502	3150	3571,2	2885	268	3210	3196	203	258	10	65
23	191.50.3550.990.41.1502	3550	3955,2	3285	268	3610	3596	203	258	10	65
24	191.50.4000.990.41.1502	4000	4411,2	3735	268	4060	4046	203	258	10	65
25	191.50.4500.990.41.1502	4500	4915,2	4235	268	4560	4546	203	258	10	65

Ring gear annealed

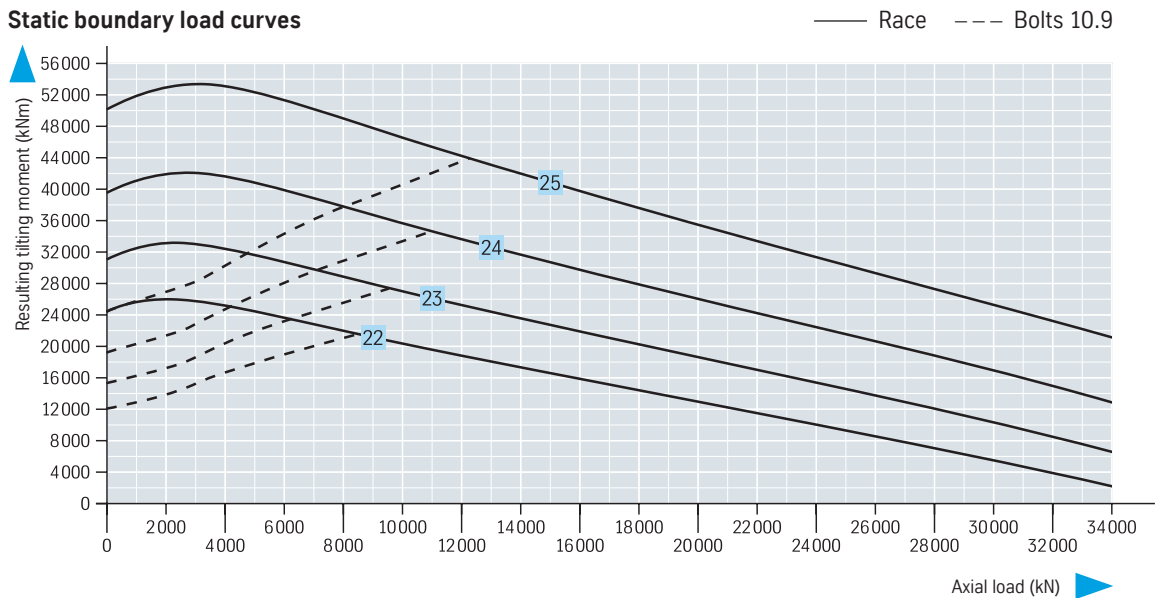

Attachment					Gearing								Miscellaneous	
$\emptyset L_a$ mm	$\emptyset L_l$ mm	n	$\emptyset B$ mm	M mm	d mm	m mm	z	x · m mm	k · m mm	b _{min} mm	X1 kN	X2 kN	kg	n ₁
3350	2975	48	45	42	3504	24	146	+ 12,0	- 2,4	202	421,57	843,13	5298	8
3750	3375	54	45	42	3888	24	162	+ 12,0	- 2,4	202	421,57	843,13	5830	9
4200	3825	60	45	42	4344	24	181	+ 12,0	- 2,4	202	421,57	843,13	6578	10
4700	4325	68	45	42	4848	24	202	+ 12,0	- 2,4	202	421,57	843,13	7456	11

Diameter tolerances

Machined diameters with untoleranced drawing dimensions have the following tolerances:

- ≤ 4000 mm ± 5,0 mm
- ≤ 6300 mm ± 7,0 mm

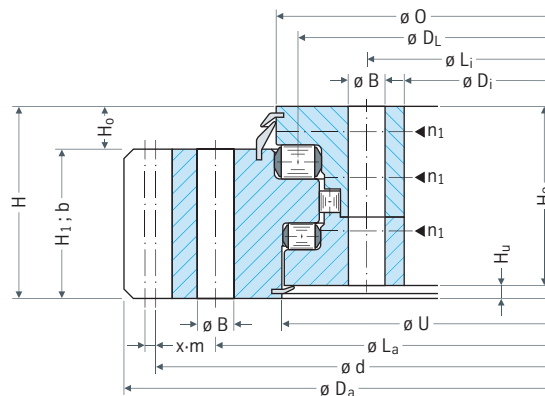

Utilization period curves – 30 000 revolutions

drawing position = mounting position

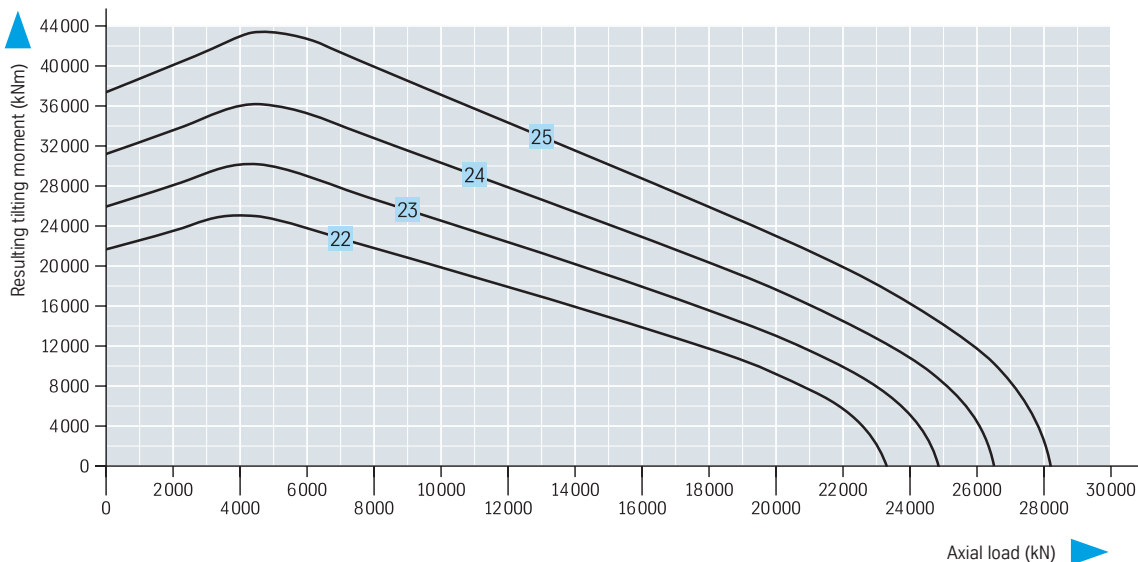

Series 19 Three-row roller bearing

Bearing with internal gearing		Geometry									
Drawing number		$\varnothing D_L$ mm	$\varnothing D_a$ mm	$\varnothing D_i$ mm	H mm	$\varnothing O$ mm	$\varnothing U$ mm	H ₁ mm	H ₂ mm	H _U mm	H _o mm
22	192.50.3150.990.41.1502	3150	3415	2736	268	3090	3104	203	258	10	65
23	192.50.3550.990.41.1502	3550	3815	3120	268	3490	3504	203	258	10	65
24	192.50.4000.990.41.1502	4000	4265	3576	268	3940	3954	203	258	10	65
25	192.50.4500.990.41.1502	4500	4765	4080	268	4440	4454	203	258	10	65

Ring gear annealed

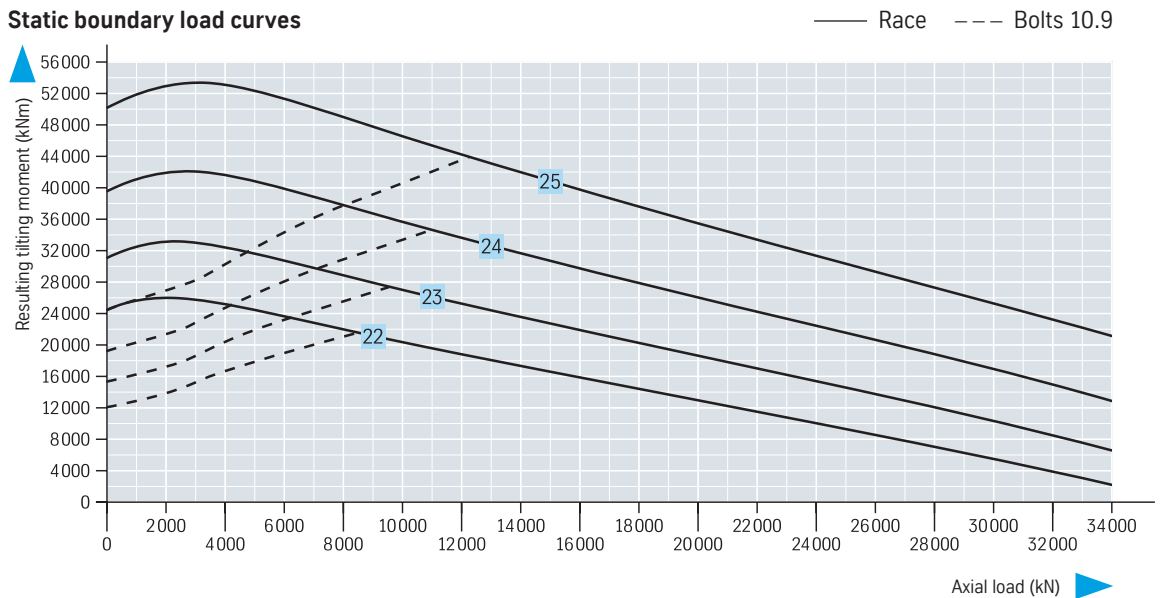

Attachment					Gearing								Miscellaneous	
$\varnothing L_a$ mm	$\varnothing L_l$ mm	n	$\varnothing B$ mm	M mm	d mm	m mm	z	x · m mm	b_{min} mm	X1 kN	X2 kN	kg	n_1	
3325	2950	48	45	42	2760	24	115	- 12,0	202	421,57	843,13	5128	8	
3725	3350	54	45	42	3144	24	131	- 12,0	202	421,57	843,13	5916	9	
4175	3800	60	45	42	3600	24	150	- 12,0	202	421,57	843,13	6623	10	
4675	4300	68	45	42	4104	24	171	- 12,0	202	421,57	843,13	7427	11	

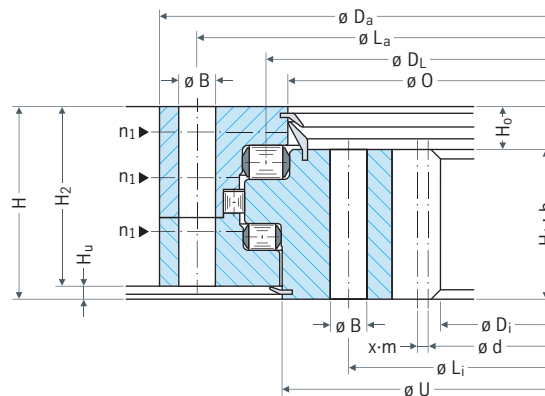

Diameter tolerances

Machined diameters with untoleranced drawing dimensions have the following tolerances:

- ≤ 4000 mm ± 5,0 mm
- ≤ 6300 mm ± 7,0 mm

Utilization period curves – 30 000 revolutions

drawing position = mounting position

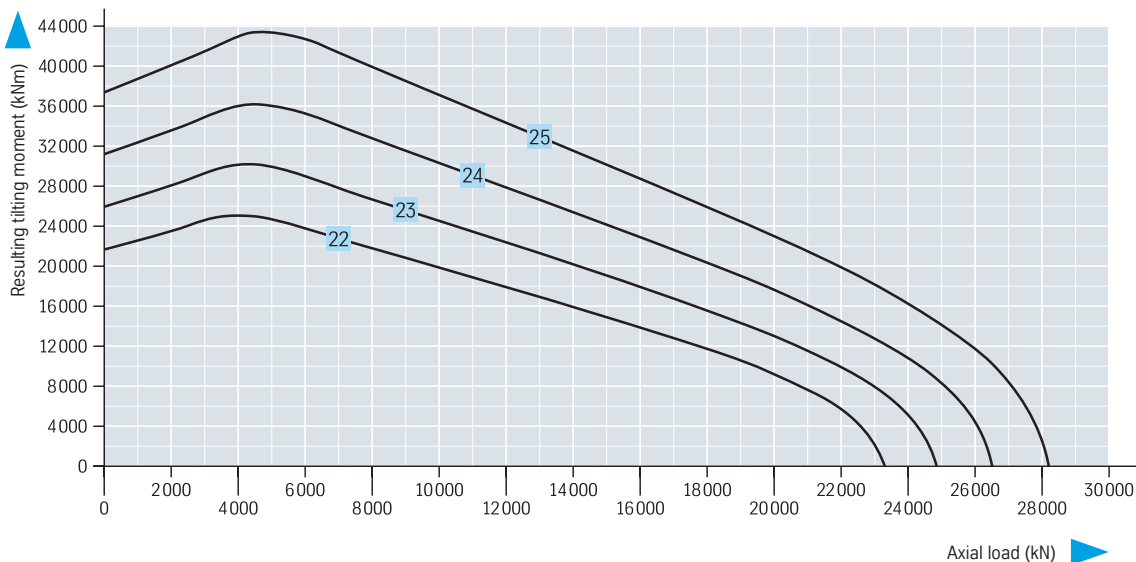

Series 19 Three-row roller bearing

Bearing with external gearing		Geometry									
Drawing number		$\varnothing D_L$ mm	$\varnothing D_a$ mm	$\varnothing D_i$ mm	H mm	$\varnothing O$ mm	$\varnothing U$ mm	H ₁ mm	H ₂ mm	H _U mm	H _o mm
26	191.50.5000.990.41.1502	5000	5419,2	4735	268	5060	5046	203	258	10	65
27	191.50.5600.990.41.1502	5600	6019,2	5335	268	5660	5646	203	258	10	65
28	191.50.6300.990.41.1502	6300	6715,2	6035	268	6360	6346	203	258	10	65
29	191.50.6735.990.41.1502	6735	7147,2	6470	268	6795	6781	203	258	10	65

Ring gear annealed

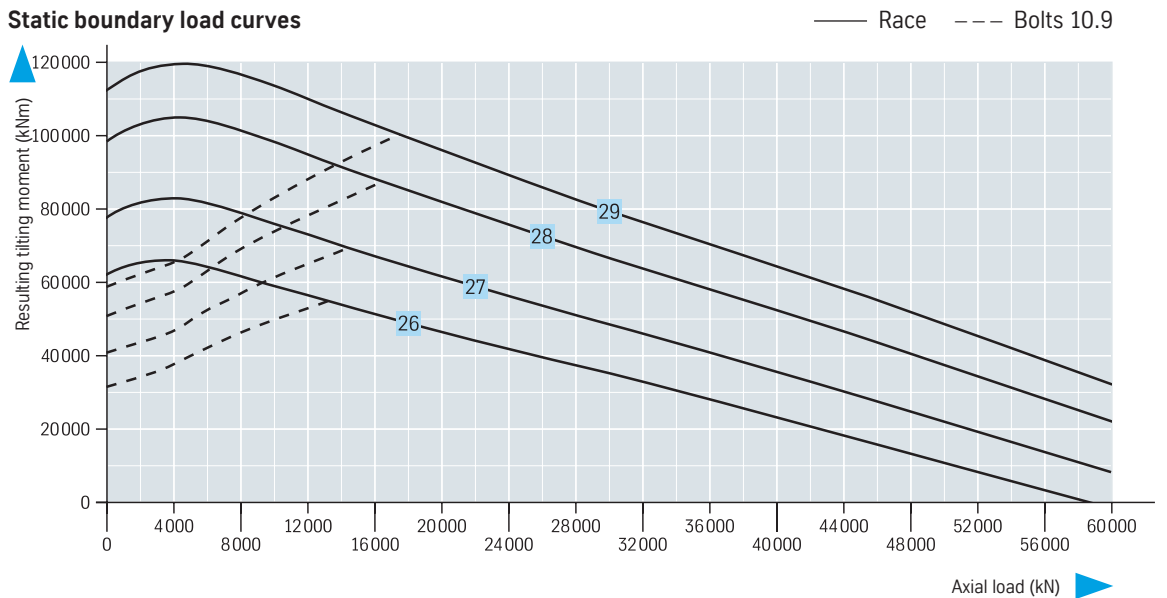

Attachment					Gearing								Miscellaneous	
$\varnothing L_a$ mm	$\varnothing L_l$ mm	n	$\varnothing B$ mm	M mm	d mm	m mm	z	x · m mm	k · m mm	b _{min} mm	X1 kN	X2 kN	kg	n ₁
5200	4825	78	45	42	5328	24	222	+ 24,0	- 2,4	202	421,57	843,13	8259	13
5800	5425	90	45	42	5952	24	248	+ 12,0	- 2,4	202	421,57	843,13	9448	15
6500	6125	100	45	42	6624	24	276	+ 24,0	- 2,4	202	421,57	843,13	10536	18
6935	6560	108	45	42	7080	24	295	+ 12,0	- 2,4	202	421,57	843,13	11200	18

Diameter tolerances

Machined diameters with untoleranced drawing dimensions have the following tolerances:

- ≤ 6300 mm ± 7,0mm
- ≤ 10000 mm ± 10,0mm

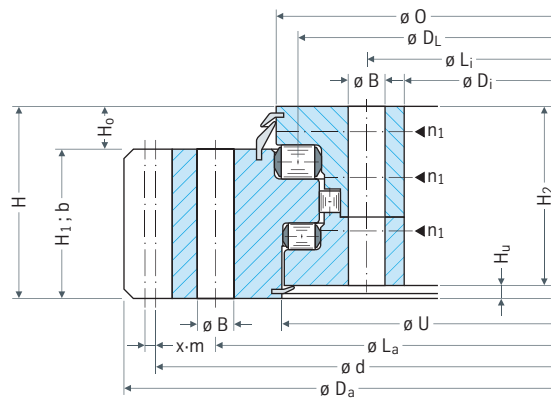

Utilization period curves – 30 000 revolutions

drawing position = mounting position

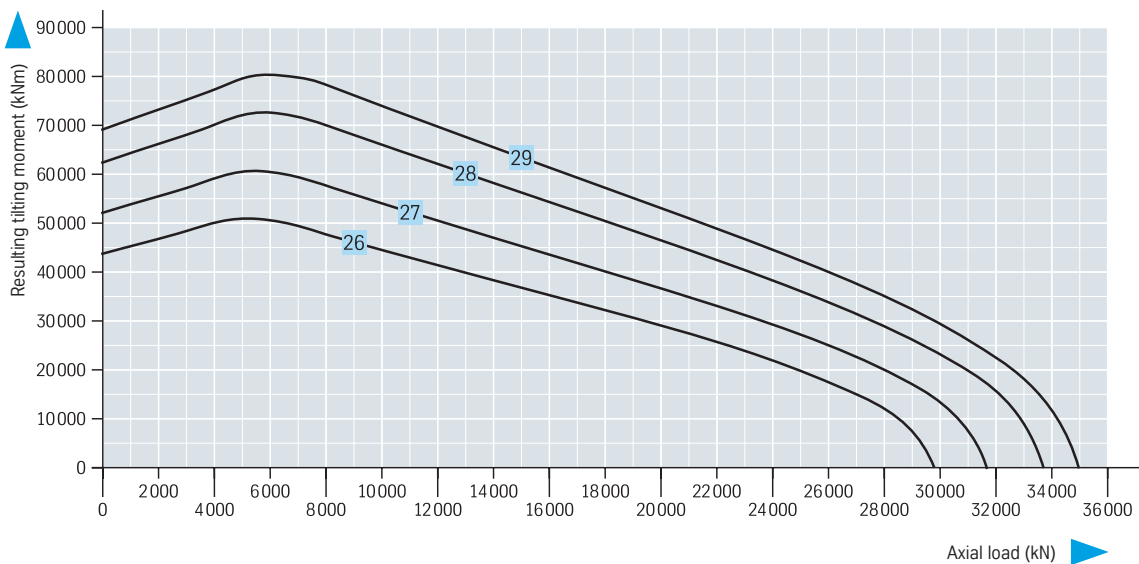

Series 19 Three-row roller bearing

Bearing with internal gearing		Geometry									
Drawing number		$\varnothing D_L$ mm	$\varnothing D_a$ mm	$\varnothing D_i$ mm	H mm	$\varnothing O$ mm	$\varnothing U$ mm	H ₁ mm	H ₂ mm	H _U mm	H _o mm
26	192.50.5000.990.41.1501	5000	5265	4584	268	4940	4954	203	258	10	65
27	192.50.5600.990.41.1502	5600	5865	5184	268	5540	5554	203	258	10	65
28	192.50.6300.990.41.1502	6300	6565	5880	268	6240	6254	203	258	10	65
29	192.50.6735.990.41.1502	6735	7000	6312	268	6675	6689	203	258	10	65

Ring gear annealed

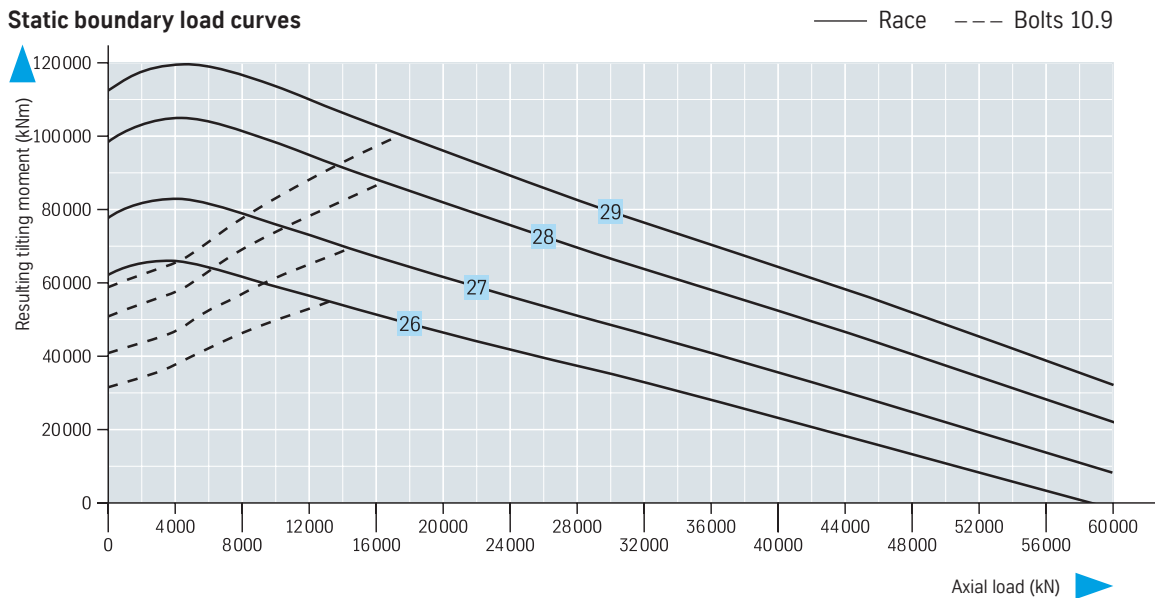

Attachment					Gearing								Miscellaneous	
$\emptyset L_a$ mm	$\emptyset L_l$ mm	n	$\emptyset B$ mm	M mm	d mm	m mm	z	x · m mm	b _{min} mm	X1 kN	X2 kN	kg	n ₁	
5175	4800	78	45	42	4608	24	192	- 12,0	202	421,57	843,13	8182	13	
5775	5400	90	45	42	5208	24	217	- 12,0	202	421,57	843,13	9317	15	
6475	6100	100	45	42	5904	24	246	- 12,0	202	421,57	843,13	10555	18	
6910	6535	108	45	42	6336	24	264	- 12,0	202	421,57	843,13	11330	18	

Diameter tolerances

Machined diameters with untoleranced drawing dimensions have the following tolerances:

- ≤ 6300 mm ± 7,0mm
- ≤ 10000 mm ± 10,0mm

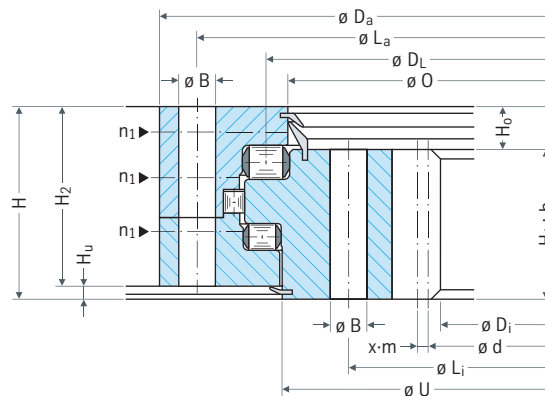

Utilization period curves – 30 000 revolutions

drawing position = mounting position

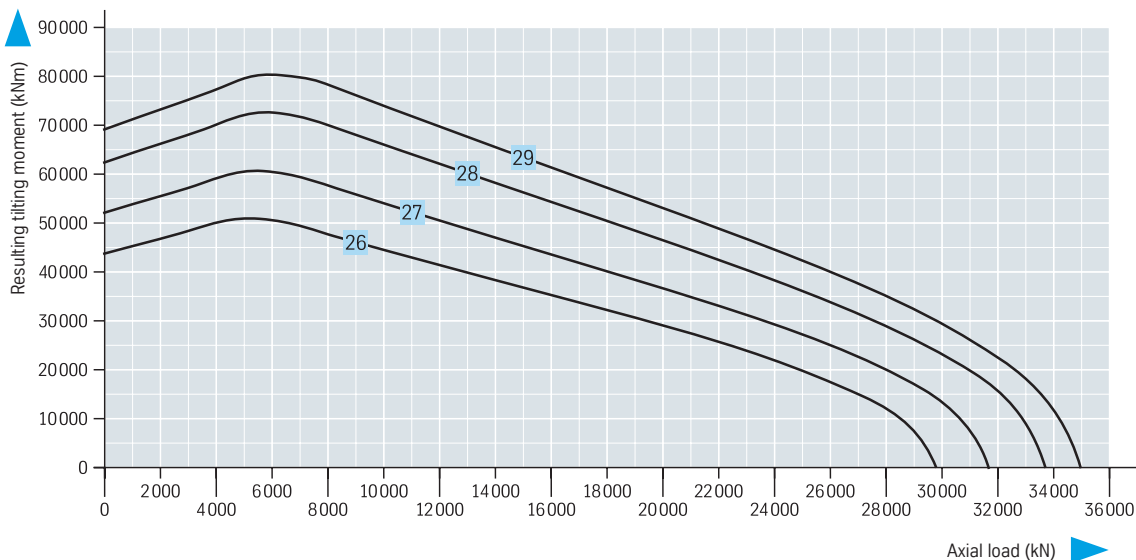

Screw connection/ bolt connections

Bolts

The high expectations on quality and service life of rothe erde® slewing bearings also requires efficient handling of bolted connections.

Boundary load curves

The boundary load curves shown in the static diagrams are in all cases related to bolts with strength class 10.9. A pre-stressing of 70% of the yield limit is a prerequisite.

In bearings without an entered bolt curve, the entire load capacity range below the boundary load curves is covered by bolts with the strength class 10.9. The maximum load without factors is applied for testing against the bolt curve.

Preconditions

The following prerequisites apply to boundary load curves:

1. The axial load F_a acts with contact from the top, not "suspended", i.e. the axial operating force F_A from the axial load does not act on the bolts with tension, see Figures 12 and 13.
2. The bolts are evenly distributed around the bolt-hole circles.
3. The connection designs comply with our technical conditions, see page 220.
4. The slewing bearing and the connection structures are made from steel.
5. No cast resin lining is provided underneath.
6. The clamping length l_k is:
 - at least $5 \cdot d$ in bearings with a full ring cross section
 - at least $3 \cdot d$ in profiled rings such as the type series 25, 23, 28.

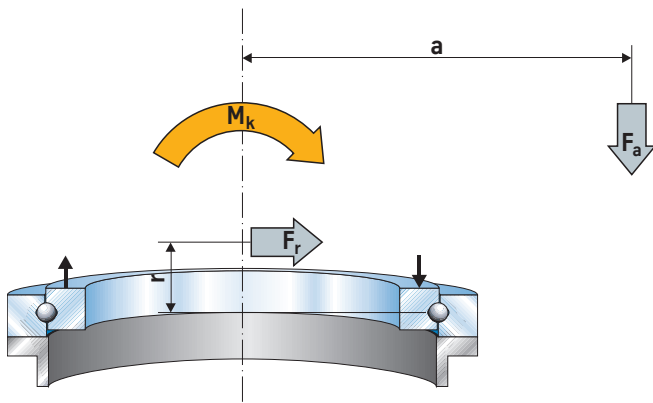

Figure 12: Axial load "application from above"

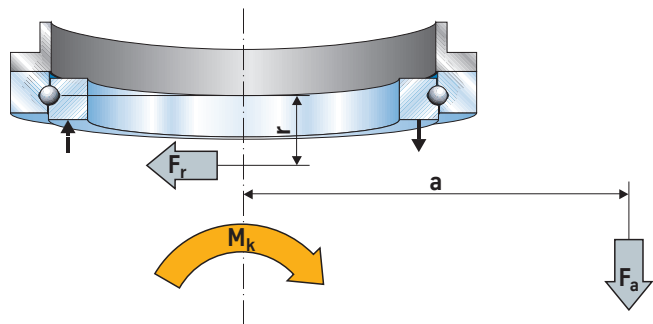

Figure 13: Axial load "suspended"

Table 2: Minimum screw-in depth with blind-hole thread for medium tolerance class (6 H)
Different tolerance classes require corresponding allocated screw-in depths

Bolt strength class	8.8/10.9	10.9/12.9	12.9	
Thread fineness d/P	$\geq 9 / < 9$	$\geq 9 / < 9$	≥ 9	d – Thread external \varnothing [mm] Bolts with metric ISO thread (standard thread)
St 37	$1,25 \cdot d$			
St 50, C 45 N, 46 Cr 2 N, 46 Cr 4 N	$1,0 \cdot d$	$1,2 \cdot d$	$1,4 \cdot d$	P – Pitch of the thread [mm] up to M 30 have a d/P < 9 > M 30 have a d/P ≥ 9
C 45 V, 46 Cr 4 V, 42 CrMo 4 V	$0,9 \cdot d$	$1,0 \cdot d$	$1,1 \cdot d$	

7. There are at least six free thread turns in the loaded part of the bolt.

Advantage The definition of standards creates planning certainty and reduces the coordination complexity.

Note Consultation is required in the event of different preconditions.

The boundary surface pressures listed in Table 3 in the contact surfaces of the bolt head and nut of the clamped parts are not allowed to be exceeded.

Advantage The loss of prestressing due to creep is avoided.

Note The selected product and strength class of the bolts and nuts must be guaranteed by the supplier. Pay attention to the identification according to DIN/ISO in this case.

Perpendicularity between the contact surface and axis of the thread of the bolt and nut must be guaranteed.

Pitch errors which result in falsification of the tightening torque especially with screw-in lengths $> 1 \cdot d$ reduce the bolt prestressing force and must be excluded.

For bolts larger than M30, it is preferable for a hydraulic bolt clamping cylinder to be used, see pages 214–215. Based on our experience, the coefficients

of friction are excessively diverse, as a result of which Table 4, page 210 does not specify any tightening torques.

Note The design must take account of an increased space requirement for bolt head, nut, tightening tool and increased size of washer. The height of the washer must be adapted to the bolt diameter. Comply with plane-parallelism.

Rough procedure for determining the surface pressure under the head or nut contact surface

Condition:

$$p = \frac{F_M / 0.9}{A_p} \leq p_G \quad [\text{kNm}]$$

F_M – Mounting prestressing force of the selected bolt [N]
 A_p – Contact surface or nut (bolt head) [mm²]
 p_G – Boundary surface pressure for the compressed parts [N/mm²]

In this case, the reduction in the contact surface due to hole chamfering as well as washer face on the hexagonal profile must be taken into account.

$$A_p = \frac{\pi}{4} (d_w^2 - d_h^2) \text{ for } d_h > d_a$$

d_h – Hole diameter
 d_a – Internal diameter of the head contact surface
 d_w – External diameter of the head contact surface

Table 3: p_G - Boundary surface pressure [N/mm²] for the compressed parts

Material	p_G boundary surface pressure
S 235 JR + AR	260 N/mm ²
E 295, C 45 N, 46 Cr 2 N, 46 Cr 4 N	420 N/mm ²
C 45, profile rolled (Series 23, 25, 28)	700 N/mm ²
C 45 V, 46 Cr 4 V, 42 CrMo 4 V	700 N/mm ²
GG 25	800 N/mm ²

If the boundary surface pressures are exceeded, washers of corresponding size and strength must be provided.

Screw connection/ bolt connections

Table 4: Clamping forces and tightening torques for bolts with metric standard thread DIN 13, für $\mu_G \approx \mu_K = 0,14$

Strength class according to DIN ISO 898 Yield strength $R_{p0,2}$ N/mm ²			10.9 940			12.9 1100		
Metric ISO-Thread DIN 13	Clamping cross-section A_s mm ²	Core cross-section A_3 mm ²	Clamping force F_M N	for hydr. + electr. M_d driver M_A Nm	for M_d '-* key M_A' Nm	Clamping force F_M N	for hydr. + electr. M_d driver M_A Nm	for M_d '-* key M_A' Nm
M 12	84,3	76,2	61 500	137	123	72 000	160	144
M 14	115	105	84 400	218	196	98 800	255	230
M 16	157	144	115 700	338	304	135 000	395	356
M 18	193	175	141 000	469	422	165 000	549	495
M 20	245	225	181 000	661	595	212 000	773	696
M 22	303	282	225 000	904	814	264 000	1057	951
M 24	353	324	260 000	1136	1025	305 000	1329	1196
M 27	459	427	342 000	1674	1506	400 000	1959	1763
M 30	561	519	416 000	2274	2046	487 000	2662	2396
M 33	694	647	517 000			605 000		
M 36	817	759	608 000			711 000		
M 39	976	913	729 000			853 000		
M 42	1120	1045	830 000			971 000		
M 45	1300	1224	968 000	Find through elongation measurement of the bolt		1 134 000	Find through elongation measurement of the bolt	
M 48	1470	1377	1 090 000			1 276 000		
M 52	1760	1652	1 312 000			1 535 000		
M 56	2030	1905	1 511 000			1 769 000		
M 60	2360	2227	1 764 000			2 064 000		

* = M_A changes with different values for μ_G or μ_K

Prestressing of the fastening bolts with tightening torque (torsion)

The tightening torque is dependent on many factors, in particular however on the friction coefficient in the thread as well as on the head or nut contact surface.

For an average friction coefficient of $m_G \approx m_K = 0.14$ (thread and contact surfaces slightly oiled), the tightening torque M_A for prestressing F_M is specified for the hydraulic torque driver.

Taking account of a distribution of $\pm 10\%$, the assembly torque M_A' is defined for the torque wrench.

Tests and practical experience show time and time again that the tightening torques obtained by calculation for bolts larger than M 30 or 1¼" do not correlate to the actual conditions with sufficient accuracy.

Friction

The main reason influencing these differences is the friction in the thread and between the head or nut contact surface, for which only values based on experience or estimations are usually available. The friction coefficient determines the magnitude of the friction force.

In addition to these influencing factors, a bolted connection is additionally subject to settling factors that are predominantly determined by the smoothing of surface roughness.

Note These influencing parameters are significantly included in the calculation of the tightening torque, as a result of which there can be significant fluctuations in the bolt prestressing.

Distribution of friction coefficients

To illustrate this uncertainty, some factors are listed that influence the distribution of friction coefficients:

1. The thread friction depends on:
 - The roughness of the thread surface, i.e. the type of thread manufacture (cut, rolled)
 - The surface treatment (e.g. bare metal, phosphated or blackened)
 - The type of lubrication (dry, lightly oiled, heavily oiled)
 - Possible surface treatment of the nut thread
 - The length of thread in contact
 - Possible repeated tightening and loosening of the bolts

2. The distribution of friction between the head or nut contact surface depends on:
 - The roughness of the contact surfaces
 - The condition of the contact surfaces (dry, lubricated, painted)
 - Hardness differences between the contact surfaces or the material pairing
 - The dimension and angle deviations in between the contact surfaces

Determining the tightening torques of fastening bolts larger than M 30 or 1b"

Variations in the tightening torque can be significantly reduced if the tightening torque for bolts larger than M30 or 1¼" is determined using the lengthways elongation of the bolt instead of being calculated.

This monitoring procedure can be carried out straightforwardly if both ends of the bolt are accessible in the bolted-on condition. If this is impossible, a model test must be carried out (Figure 14, page 212).

Calculation of the required lengthways elongation by means of the elastic resilience of the bolt

This produces

$$\delta = \frac{l}{E \cdot A}$$

$$\delta_s = \delta_K + \delta_1 + \delta_2 + \delta_{GM}$$

Head

Shank

Thread part not screwed in

Thread part screwed in

where $l_G = 0.5 d$ and $l_M = 0.4 d$

for nuts according to DIN EN ISO 4032

$$\delta_s = \frac{0.4 d}{E_s \cdot A_N} + \frac{l_1}{E_s \cdot A_N} + \frac{l_2}{E_s \cdot A_3} + \frac{0.5 \cdot d}{E_s \cdot A_3} + \frac{0.4 \cdot d}{E_s \cdot A_N}$$

The force assigned to the length allocation in the elastic range is:

$$F_M = \frac{1}{\delta_s} \Delta \quad [N]$$

Determining the prestressing force when using 70% of the yield limit in relation to the clamping cross-section:

$$F_M = 0.7 \cdot R_{p0.2} \cdot A_s \quad [N]$$

$$F_{0.2} = R_{p0.2} \cdot A_s \quad [N]$$

$R_{p0.2}$ for strength class 8.8

= 640 N/mm² for $d \leq 16$

= 660 N/mm² for $d > 16$

$R_{p0.2}$ for strength class 10.9

= 940 N/mm²

$R_{p0.2}$ for strength class 12.9

= 1100 N/mm²

In which case:

$$\Delta l = F_M \cdot \delta_s \quad [mm]$$

Screw connection/ bolt connections

Model test

The equivalent clamping length must be created using steel blocks of the same general size. Also, the surface composition of that surface on the model that is located under the part which turns during tightening (bolt head or nut) should correspond to the object. As a rule, hardened washers are used, meaning that this condition is easy to meet. The influence of a different number of separating gaps can hardly be measured and must therefore be disregarded.

The distribution normally to be expected is considered in the calculation in the tightening factor. The test ensures that the minimum clamping force of these larger bolts is also within the values assumed for the calculation.

For the bolt which is to be used, the elastic lengthways elongation under 70% pre-stressing in relation to the yield limit is calculated based on the elastic resilience of the bolt according to the clamping length.

The bolt is prestressed until the previously calculated bolt elongation Δl is displayed on the measuring gauge. The torque is then read off the clamping tool after the Δl dimension has been reached.

Note Several measurements should be performed and the average calculated because of possible spreads.

When a clamping tool with a socket is used for tightening the nut, this means the measuring bar must be removed and so the test bolts should be provided with a centering hole (Figure 14) at both ends, thereby largely excluding sources of errors due to incorrect application of the measuring bar.

Advantage Now, all fastening bolts on the slewing bearing can be prestressed with this uniform tightening torque.

Note In this case, the clamping tool used in the test must be used. Furthermore it is

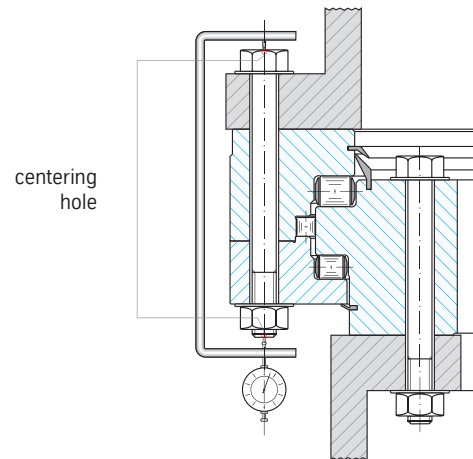

Figure 14

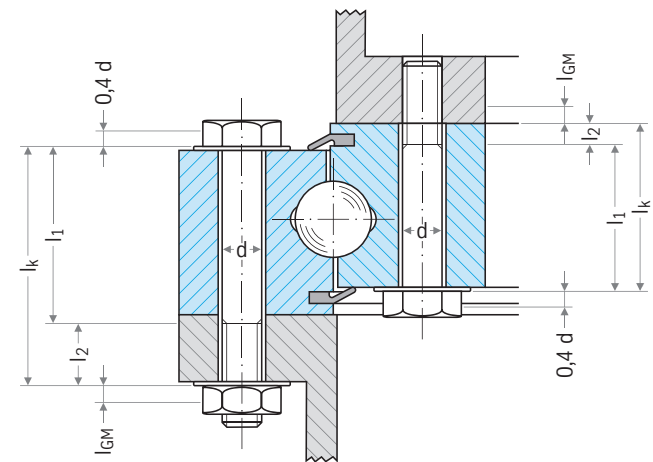

Figure 15

Expressions used in the formulas

A_N	= Nominal cross-section of the bolt	[mm ²]
A_3	= Core cross-section of the thread	[mm ²]
A_S	= Clamping cross-section of the bolt thread	[mm ²]
E_S	= Modulus of elasticity of the bolt	205 000 [N/mm ²]
F_M	= Assembly clamping force	[N]
$F_{0,2}$	= Bolt force on the minimum yield limit	[N]
l_1	= Elastic pin length	[mm]
l_2	= Elastic length of the thread	[mm]
Δl	= Change in length when tightening the bolt	[mm]
δ_S	= Elastic resilience of the bolt	[mm/N]
$R_{p0,2}$	= Tension on the yield limit of the bolt material	[N/mm ²]
l_k	= Clamping length of the bolt	[mm]
l_{GM}	= Thread length l_G and nut dislocation l_M taken into account for the resilience of the screwed-in part of the thread; $l_{GM} = l_G + l_M$	[mm]

necessary to ensure that the bolts to be used and test bolts come from one production batch.

Prestressing of the fastening bolts with a hydraulic bolt clamping cylinder (torsion-free)

Negative influences on the bolt prestressing can be most effectively reduced by hydraulic clamping cylinders, in particular in bolts with relatively large diameter.

Advantage The additional loading on the bolt cross-section due to torsion and bending does not occur, in contrast to the conventional torque method. Thanks to the lack of friction, the remaining bolt prestressing force can be precisely defined – taking account of corresponding configuration parameters after previous investigations.

Note Prestressing diagonally across, with care, until reaching the prescribed values. In this case, depending on the tightening process, a tightening factor α_A of 1.2 up to 1.6 can be used in the calculation, and the yield strength of the bolt can be exploited up to 90% in the calculation.

The prestressing of the bolt that is tightened first is influenced by tightening of the other bolts. Therefore, it is necessary to provide at least two rotations.

Advantage This also compensates for the settling that occurs when prestressing nonloaded joining surfaces (thread and nut contact surface).

The theoretical clamping forces for a selected series of bolts can be seen in Table 7, page 215.

Note Insufficient parallelism between the nut and contact surface and the thread tolerance means that in this process as well, settling appearances after tightening of the nut cannot be excluded. (Perpendicularity tolerance is constrained at the bolt and nut manufacturer.)

In this process, not only the shank but also the thread is elastically stretched due to the applied clamping force, which means having the correct thread series or thread tolerances according to DIN 2510 is important. An inadequate thread play can result in nut seizing on a stretched bolt.

Note Taking account of the nut height used, it is essential to reach an agreement with the supplier of the clamping cylinders.

Screw connection/ bolt connections

Table 5: ITH – One-stage bolt clamping cylinder type ES

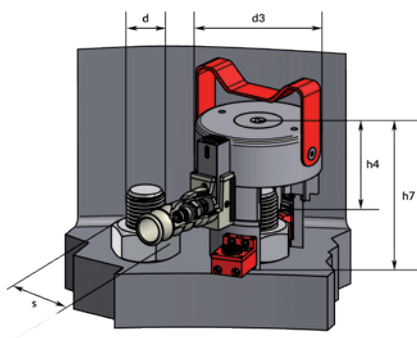

Type	Order no.	Preload force		Nominal diameter bolt ϕ d		Width across flats s		External ϕ d3		Installation dimension h4		Overall height h7	
		[kN]	[lbs]	[mm]	["]*	[mm]	["]	[mm]	["]	[mm]	["]	[mm]	["]
ES 24 - 10.9	33.05441	306	68837	M 24x3	7/8	36	1 4/9	77,5	3,05	92,0	3,62	116,5	4,59
ES 27 - 10.9	33.05442	400	89834	M 27x3	1	41	1 5/8	87,5	3,44	90,5	3,56	116,5	4,59
ES 30 - 10.9	33.05443	486	109280	M 30x3,5	1 1/8	46	1 4/5	96,0	3,78	92,0	3,62	121,0	4,76
ES 33 - 10.9	33.05444	604	135875	M 33x3,5	1 1/4	50	2	105,0	4,13	105,2	4,14	137,3	5,41
ES 36 - 10.9	33.05445	712	160053	M 36x4	1 3/8	55	2 1/5	115,0	4,53	98,4	3,87	132,4	5,21
ES 39 - 10.9	33.05446	849	190787	M 39x4	1 1/2	60	2 3/8	124,5	4,90	102,8	4,05	139,2	5,48
ES 42 - 10.9	33.05447	981	220516	M 42x4,5	1 5/8	65	2 4/7	134,0	5,28	111,2	4,38	156,7	6,17
ES 45 - 10.9	33.05448	1146	257599	M 45x4,5	1 3/4	70	2 3/4	144,0	5,67	114,0	4,49	153,0	6,02
ES 48 - 10.9	33.05449	1290	290005	M 48x5	1 7/8	75	3	154,0	6,06	105,2	4,14	157,2	6,19
ES 52 - 10.9	33.05450	1540	346207	M 52x5	2	80	3 1/8	167,0	6,57	131,3	5,17	176,3	6,94
ES 56 - 10.9	33.05451	1775	399038	M56x5,5	2 1/4	85	3 1/2	177,7	7,00	131,0	5,16	179,0	7,05
ES 60 - 10.9	33.05452	2075	466618	M 60x5,5	2 3/8	90	3 3/4	193,0	7,60	138,5	5,45	190,5	7,50
ES 64 - 10.9	33.05453	2325	522728	M 64x6	2 1/2	95	3 7/8	204,0	8,03	191,4	7,54	239,4	9,43
ES 68 - 10.9	33.05454	2685	603700	M 68x6	2 3/4	100	4 1/4	219,5	8,64	135,3	5,33	193,3	7,61
ES 72 - 10.9	33.05455	3010	676694	M 72x6	3	105	4 5/8	231,5	9,11	160,4	6,31	221,4	8,72
ES 80 - 10.9	33.05456	3.691	829839	M 80x6	3 1/4	115	5	253,0	9,96	155,4	6,12	223,4	8,80
ES 90 - 10.9	33.05457	4.657	1046850	M 90x6	3 1/2	130	5 3/8	288,0	11,34	176,5	6,95	253,5	9,98
ES 100 - 10.9	33.05458	5.810	1306218	M 100x6	4	145	6 1/8	322,0	12,68	199,4	7,85	284,4	11,19

	Available bolt / nut configuration for thyssenkrupp rothe erde Germany GmbH	Order no. Key	Example type ES 36
Standard	Standard hexagon nut according to DIN ISO 4032	XX = 00	33.05445-10-50000-10-13
Optional	Nut (DIN 934) + washer (EN ISO 7090:2000, formerly DIN 125)	XX = 10	33.05445-10-50010-10-13
More	Other bolt / nut configurations possible on request		

Table 6: ITH – Multi-stage bolt clamping cylinder type MSK

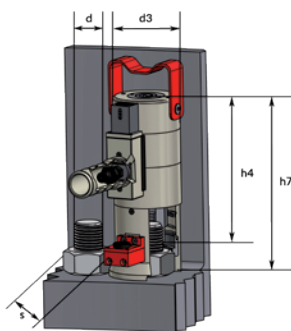

Type	Order no.	Preload force		Nominal diameter bolt ϕ d		Width across flats s		External ϕ d3		Installation dimension h4		Overall height h7	
		[kN]	[lbs]	[mm]	["]*	[mm]	["]	[mm]	["]	[mm]	["]	[mm]	["]
MSK 24 - 10.9	33.50091	308,5	69354	M 24x3	7/8	36	1 4/9	57,0	2,24	164,0	6,46	188,7	7,50
MSK 27 - 10.9	33.50092	401,5	90261	M 27x3	1	41	1 5/8	63,5	2,50	170,6	6,72	197,4	7,86
MSK 30 - 10.9	33.50093	485,5	109152	M 30x3,5	1 1/8	46	1 4/5	70,0	2,76	170,7	6,72	199,2	7,98
MSK 33 - 10.9	33.50094	606,3	136302	M 33x3,5	1 1/4	50	2	78,3	3,08	190,0	7,48	222,6	8,84
MSK 36 - 10.9	33.50095	708,3	159233	M 36x4	1 3/8	55	2 1/5	82,6	3,25	201,0	7,91	235,0	9,33
MSK 39 - 10.9	33.50096	842,2	189335	M 39x4	1 1/2	60	2 3/8	90,8	3,57	219,4	8,64	255,8	10,21
MSK 42 - 10.9	33.50097	974,4	219044	M 42x4,5	1 5/8	65	2 4/7	98,0	3,86	220,0	8,66	257,0	10,35
MSK 45 - 10.9	33.50098	1140,5	256396	M 45x4,5	1 3/4	70	2 3/4	105,0	4,13	234,9	9,25	274,0	10,98
MSK 48 - 10.9	33.50099	1288,4	289645	M 48x5	1 7/8	75	3	111,5	4,39	245,8	9,68	287,0	11,57
MSK 52 - 10.9	33.50100	1529,7	343899	M 52x5	2	80	3 1/8	122,0	4,80	256,3	10,09	301,2	12,09
MSK 56 - 10.9	33.50101	1785,0	401286	M56x5,5	2 1/4	85	3 1/2	130,5	5,14	281,0	11,59	329,0	13,80
MSK 60 - 10.9	33.50102	2125,8	477892	M 60x5,5	2 3/8	90	3 3/4	140,8	5,54	284,5	11,42	336,0	13,46
MSK 64 - 10.9	33.50103	2336,8	525336	M 64x6	2 1/2	95	3 7/8	147,8	5,82	290,4	11,43	344,5	13,87
MSK 68 - 10.9	33.50104	2745,0	617103	M 68x6	2 3/4	100	4 1/4	159,8	6,29	318,4	12,54	375,8	14,86
MSK 72 - 10.9	33.50105	3041,2	683697	M 72x6	3	105	4 5/8	168,0	6,61	324,0	12,76	385,0	15,24
MSK 80 - 10.9	33.50106	3814,1	856746	M 80x6	3 1/4	115	5	182,0	7,16	370,0	14,60	439,0	17,28
MSK 90 - 10.9	33.50107	489,0	1045361	M 90x6	3 1/2	130	5 3/8	211,0	8,30	408,0	16,06	485,0	19,09
MSK100 - 10.9	33.50108	6134,1	13790000	M 100x6	4	145	6 1/8	230,0	9,05	425,4	16,75	510,4	20,08

	Available bolt / nut configuration for thyssenkrupp rothe erde Germany GmbH	Order no. Key	Example type ES 36
Standard	Standard hexagon nut according to DIN ISO 4032	XX = 00	33.50095-10-50000-10-13
Optional	Nut (DIN 934) + washer (EN ISO 7090:2000, formerly DIN 125)	XX = 10	33.50095-10-50010-10-13
More	Other bolt / nut configurations possible on request		

Table 7: Clamping force for bolts taking account of the thread tolerances for “Metric thread with large clearance” DIN 2510 – sheet 2 – when using hydraulic bolt clamping cylinders

Strength class according to DIN ISO 898 Yield strength $R_{p0,2}$ N/mm ²				10.9 940	
Metric ISO thread DIN 13 Nominal Ø mm	Pitch mm	With tolerances according to DIN 2510		Clamping force at the yield limit $F_{0,2}$ N	Theoretical clamping force utilization $F_M = 0.9 \cdot F_{0,2}$ N
		Clamping cross-section A_s mm ²	Core cross-section A_3 mm ²		
16	2	148	133	139100	125200
20	2,5	232	211	218000	196000
24	3	335	305	315000	283000
27	3	440	404	413000	372000
30	3,5	537	492	504000	454000
33	3,5	668	617	627000	564000
36	4	786	723	738000	664000
39	4	943	873	886000	797000
42	4,5	1083	999	1018000	916000
45	4,5	1265	1174	1189000	1070000
48	5	1426	1320	1340000	1206000
52	5	1707	1590	1604000	1443000
56	5,5	1971	1833	1852000	1666000
64	6	2599	2426	2443000	2198000
72	6	3372	3174	3169000	2852000
80	6	4245	4023	3990000	3591000
90	6	5479	5226	5150000	4635000
100	6	6858	6575	6446000	5801000

Bolt length

The bolts shall be provided with sufficient length so that at least $1.0 \cdot d$ is left clear above the nuts for positioning the hydraulic clamping cylinders.

The precise minimum length depends on the strength class of the bolts and the clamping tool used. Washers shall be of sufficient size so that when the bolts are tightened by the clamping cylinder, they are pressed against the contact surface.

Increased size washers are to be preferred over standardized washers. The height of the washer depends on the thread size. As a rule, as the thread diameter increases, it should also become larger. Coordination

with the manufacturer of the clamping cylinder is essential.

The hydraulic clamping cylinders require more space above the bolt to be tightened than torque wrenches do, for example.

We recommend bolt clamping cylinders from the following company, for example **ITH GmbH & Co. KG**, Steinwiese 8, Postbox 1365, D-59872 Meschede. The quality management system of **ITH** is certified to DIN EN ISO 9001, EN 29001.

For bolts that are prestressed by torque there are also hydraulic **ITH**-torque drivers available.

Increase in friction coefficient between the bearing contact surfaces

Increase in friction coefficient zinc

Increase in friction coefficient between the contact surface can be achieved by zinc flame-spraying galvanization (in this case, the permitted levelness deviations in Table 8, page 225 must be complied with). Furthermore, Loctite can be used.

Increase in friction coefficient by flame spraying

- Preparation of the surfaces according to DIN EN 13 507
- Zinc flame-spraying galvanization according to blasting Sa 3 ISO 8501-1, zinc flame-spraying according to DIN EN ISO 2063 (in which case the permitted levelness deviations in Table 8, page 225 must be complied with).



Figure 16: Application of Loctite

Increase in friction using Loctite-586



CAUTION



Risk of skin irritation caused by friction coefficient improver/adhesive

- Safety gloves must be worn when handling friction coefficient improvers/adhesives
- Pay attention to the producer's data

The surface roughness of the surfaces to be connected should not exceed a value of Rt 65, since larger surface roughness values reduce the shear strength.

Theoretically, the quantity required for a layer of 0.1 mm is 100 ml/m².

Note If the layer is to be applied by hand, it is advisable to use double or triple this quantity, since dosage by hand cannot always be absolutely accurate.

Assembly

Note the following points during assembly:

1. Cleaning of contact surfaces with a commercially available cleaning agent to remove any oil or grease.
2. Inactive surfaces (e.g. galvanized and coated surfaces, aluminum, non-metallic surfaces, etc.) must be pretreated with activator 7471. Loctite 586 must only be applied to the non-activated surface. If both sides are active, or if Loctite is applied onto the activator, premature curing may result (drying within a few minutes).
3. Loctite must be applied with a brush onto one surface (Figure 16).
4. Spigot locations must not come into contact with Loctite. They must be coated with a separating agent, e.g. wax or grease.

5. Tightening the fastening bolts. Loctite will start curing from **about 30 min.** after positioning of the bearing. If it is not possible to fully tighten the bolts during this period, manual tightening will suffice as a preliminary solution. Ultimate strength after 12–24 hours.
6. Through holes and tapped holes have to be protected against Loctite (Figure 17).

Disassembly

The Loctite joint will resist compressive and shear forces, but not tension. Therefore, separating the bearing from its companion structure does not present any difficulties.

When using Loctite, the best solution is to incorporate tapped holes for jacking screws right at the design stage of the companion structure.

Note Use Loctite 620 at temperatures > 60°C. The installation and removal instructions are the same as for Loctite 586.

Note For large and heavy bearings and/or a horizontal axis of rotation, the use of jacking screws is imperative, especially when the mounting space is restricted.

To lift the bearing off, the jacking screws are tightened consecutively until the bearing works itself free.

With smaller bearings and easily accessible mounting space, it may suffice to carefully lift the bearing at one side, e.g. by applying a pinch bar at several points around the circumference.

Under no circumstances should the bearing be suspended from eye bolts and lifted off before the joint has been released in the manner described above.

Before reassembly, the surfaces are best cleaned by means of a wire brush.

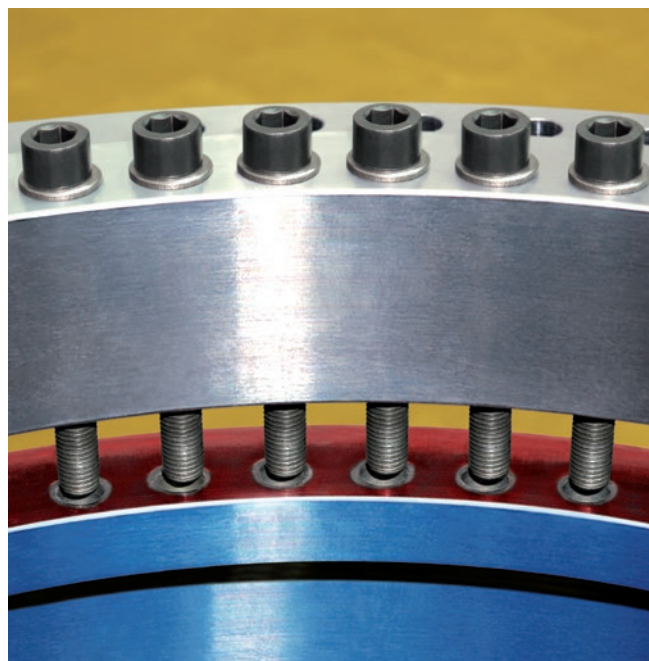

Figure 17: Through holes and tapped holes have to be protected against Loctite

Gearing

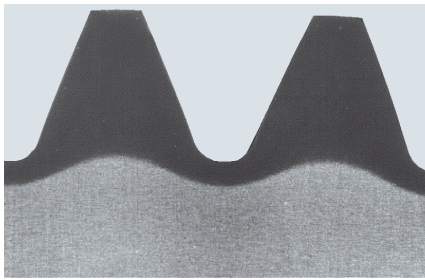

Figure 18: Circulation hardening

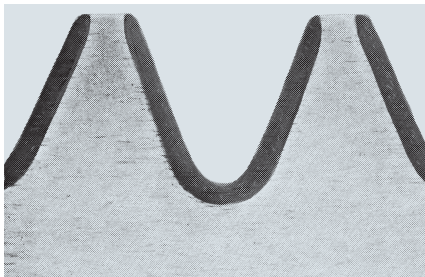

Figure 19: Tooth root hardening

Optimized design

Integrating the gearing into one of the bearing rings offers potential savings for the customer. In most cases, slewing bearings are configured with spur gearing. In this case, the gearing is cut into one of the bearing rings.

Advantage No additional driving gear wheel is required: this saves design work and costs.

Note Preferably, bearings with corrected gearing are used, addendum modification coefficient $x = 0.5$.

Long service life

For gears subjected to high tooth flank stress, hardened gears have proven very satisfactory for extending the service life. Depending on module and ring diameter, the gear rings are subjected to spin hardening or individual tooth induction-hardening, the latter predominantly in the form of tooth contour hardening.

Advantage Improved flank load carrying capacity at the same time as higher tooth root strength.

Note Hardened gearing requires individual calculation. We need to know the pinion data in order to be able to check the meshing geometry.

Reduced wear

Correct tooth backlash is a prerequisite for trouble-free operation. It significantly influences the wear. Therefore, during assembly of the drive pinion, adequate backlash must be assured.

Advantage Correct backlash ensures low-wear operation and also extends the service life.

Note The tooth backlash must be set on the three teeth marked in green with $0.03 - 0.04 \times \text{module}$. After final assembly and tightening of all the fastening bolts, the backlash must be checked.

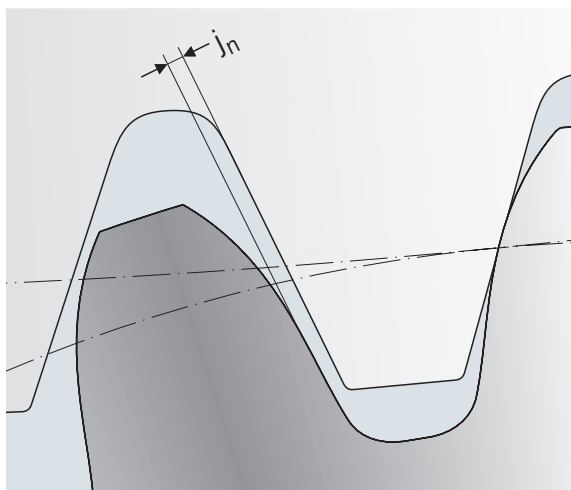

Figure 20: Backlash

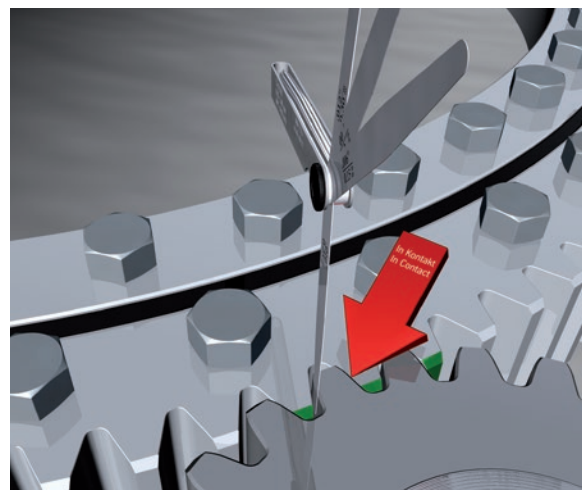

Figure 21: Measuring the flank backlash

Maintaining functional safety

Highly-loaded gearing (force-carrying gearing) requires special measures to be taken to ensure its function. This is because in spite of a correct geometrical profile and theoretically perfect gear pairing, there can still be meshing problems. These occur primarily in gears with an inadequate tooth tip edge relief combined with hardened pinions, in which case the tip edge of the pinion generates abrasive wear on the flanks of the gear. The causes of such meshing problems such as “scuffing” or “chipping” at the dedendum flank of the gear are various.

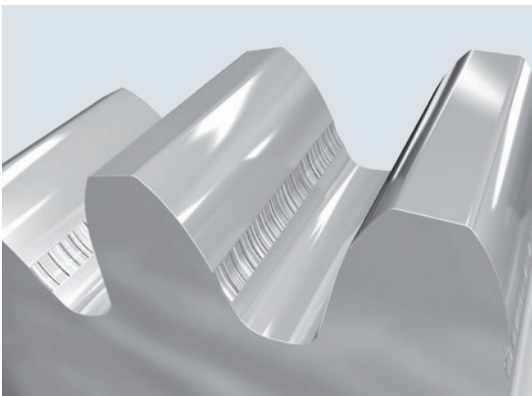

Figure 22: Scuffing

$$C_a = 0.01 \cdot m$$

$$h = 0.4 \text{ to } 0.6 \cdot m$$

$$C_a : h = 1 : 40 \text{ to } 1 : 60$$

(In relation to the full tooth width)

$$R \text{ approx. } 0.1 \text{ to } 0.15 \cdot m$$

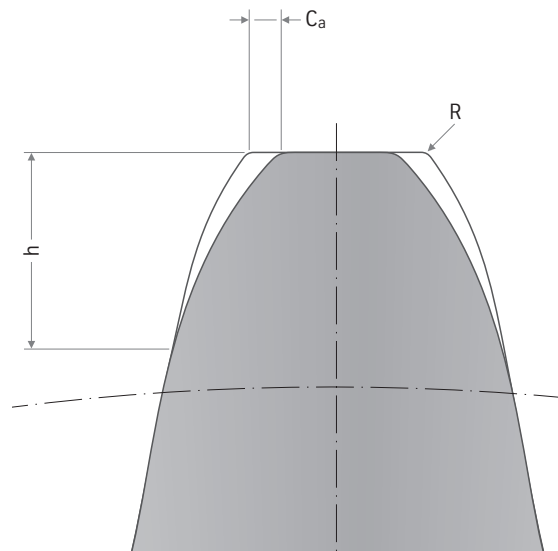

Figure 23: Tip flank profile

Bending

Elastic deformation due to load peaks – caused by acceleration, vibration or the effects of force – changes the contact behavior of the meshing teeth.

Slewing drive

Elastic deformation in the area of the drive bearings changes the tooth meshing.

Lubrication

Selecting an unsuitable lubricant (not on our recommended list, see table 10, page 229) can result in the lubricant film becoming compromised, leading to increased wear on the head edge.

As a result of these risks we require the use of pinions with a tip flank relief and tip edge rounding of 0.1 - 0.15 x m rounding radius (R) for such applications.

In this case, the radius R must blend into the addendum flank without forming an edge. This change towards an involute-like shape ensures a smooth transition from the modified tip flank profile to the normal flank profile.

Advantage Reduced tendency to meshing problems with highly stressed gearing (forcetransmission gearing).

Companion structure

Perfect connections

For reasons of better economy, the bearing cross-sections of slewing bearings are kept relatively small in comparison to their diameter. However, even with small diameters, rothe erde® slewing bearings can transmit very high loads because of their specific load carrying capacity. They therefore depend on a rigid and distortion-resistant companion structure. Those of us correspondingly designed bolts ensure the connection of the companion structures to the bearing and thus for an optimal load transfer.

Advantage Deformations under the operating loads that occur are largely prevented in connection with suitable companion structures.

Figure 25 shows: The vertical supports of the companion structure must be located in the vicinity of the raceway diameter in order to limit bowing of the contact surfaces under extreme operating loads.

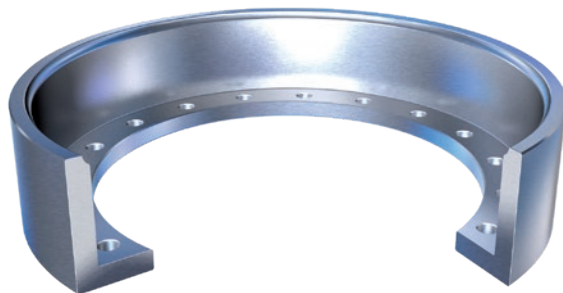

Figure 24: Connection pot

Rings

thyssenkrupp rothe erde Germany GmbH is one of the world's leading manufacturers of seamlessly rolled rings. These are produced with a large number of cross-sections and, on request, machined according to your specifications. Ring carriers (rolled connection flanges with rotation system as shown in Figure 24) offer decisive advantages for the companion structure.

Advantage Torsionally rigid attachment of the slewing bearings. Optimum load transfer between the anti-friction bearing and companion structure.

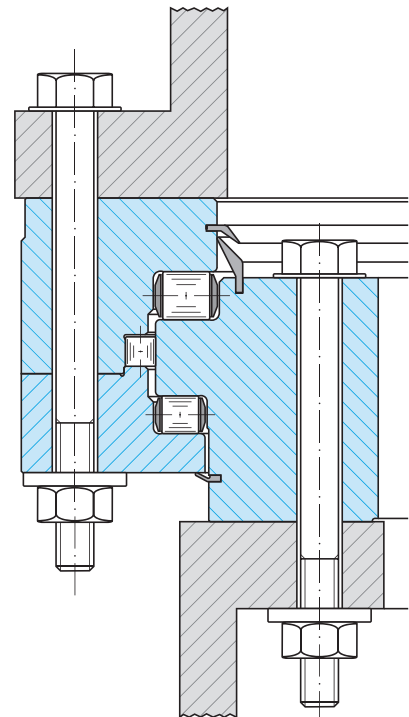

Figure 25: Companion structure

Measuring and machining of the contact surfaces, permitted levelness deviations of the companion structures

Before the slewing bearing is installed, we recommend measuring the contact surfaces using a laser measuring instrument.

If the measured values are outside our tolerances, we advise reworking by machining. If the machining of large-volume companion structures presents difficulties, use of transportable machine tools can provide a solution, even for superstructures and overhead machining. Service providers carry out this work on site.

Note The levelness of the companion structure must be complied with; to avoid local overloads due to narrow points in the raceway, it is necessary to prevent peaks being formed in small sectors. In the area from 0° - 180°, the curve profile of the levelness deviation is only allowed to rise evenly and then fall again.

Permitted levelness deviations of the machined contact surface for rothe erde® slewing bearings

The maximal permitted levelness deviations according to DIN EN ISO 1101 can be found in Table 8, page 225. See also Figure 26 in this regard.

Advantage Compliance with levelness deviations ensures the service life of the slewing bearing is achieved.

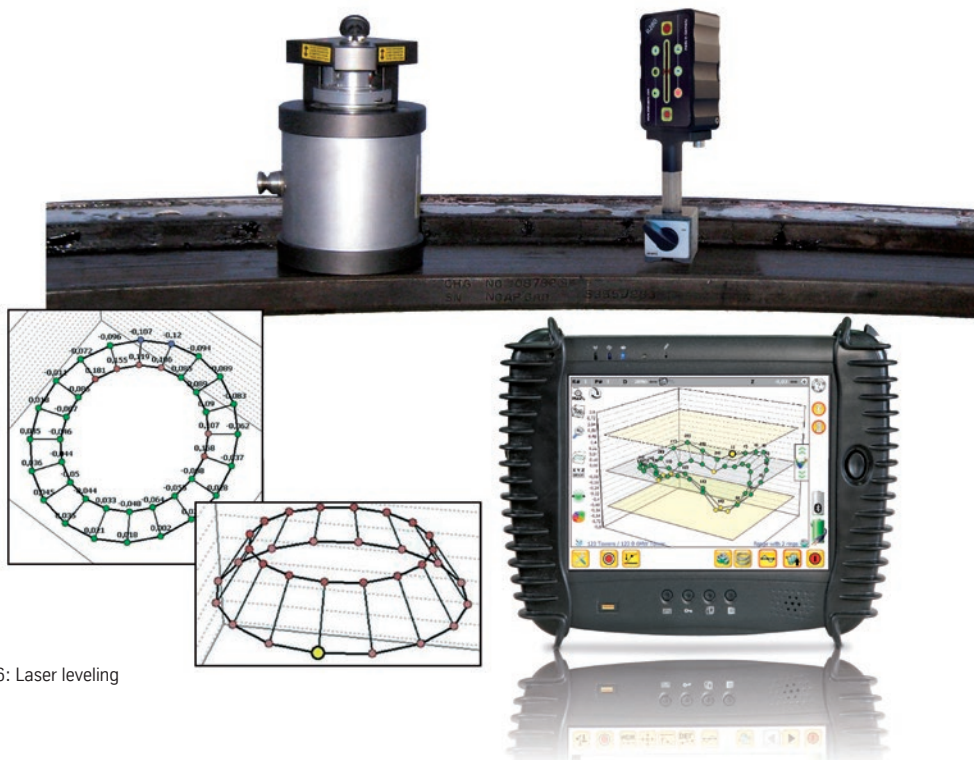

Figure 26: Laser leveling

Bearing installation, gearing, companion structures, application conditions

Application conditions

Standard and special solutions

In most cases, slewing bearings are operated in pivot-ing operation or with slow rotational movements. The following information is also based on this.

Sudden shock loads that require a high toughness of the material shall be listed separately.

It goes without saying, however, that rothe erde® slewing bearing are also configured for speeds with a higher circumferential velocity. In this case, however, the raceway and gearing must be tested and adapted specially, so you are requested to provide you application conditions and requirements in this case.

Advantage You receive the optimum design solution for your individual requirement profile, irrespective of the rotation movement and speed.

Note Operation with a horizontal axis of rotation requires our examination in all cases.

Operating temperature

thyssenkrupp rothe erde Germany GmbH, by selecting and processing corresponding materials, is capable of offering slewing bearings for a wide range of temperatures. In the normal version, the products are designed for operating temperatures from -20° to $+60^{\circ}\text{C}$. A suitable lubricant must be used in each case (see the information on page 229).

For more extreme operating temperatures and/or temperature differences between the outer and inner rings we must be advised beforehand so that checks can be carried out. Requirements regarding the mechanical properties of the ring material are of particular importance.

Classification/special conditions

For application areas with particular requirements such as offshore systems or deck cranes, there is generally speaking a classification in place according to the application conditions. In this case, acceptance of the bearing according to the catalog of requirements of the particular classification society is a requirement.

Please provide us with the detailed regulations so that we can suggest the ideal bearing for, taking account of such specifications.

Seals

Seals protect the race system against external environmental influences such as dust and water, and keep the lubricant in the bearing race system.

An evenly distributed collar of grease supports the seal function (dust seals).

For applications in general engineering, open-cast mining, offshore or wind energy, we offer a wide variety of special seal solutions to protect the race system against other environmental conditions such as dirt buildup, water or aggressive media. (see Figs. 27 and 28)

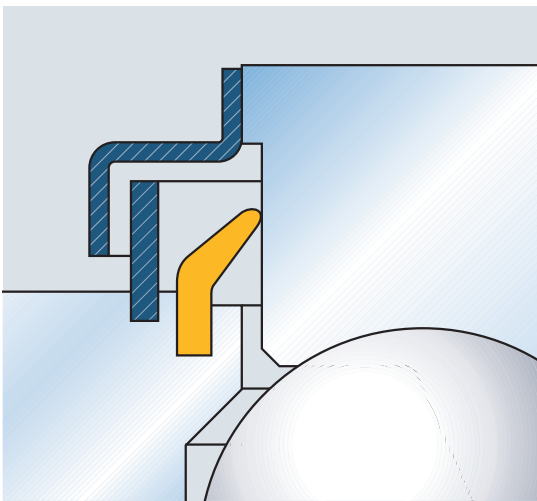

Figure 27

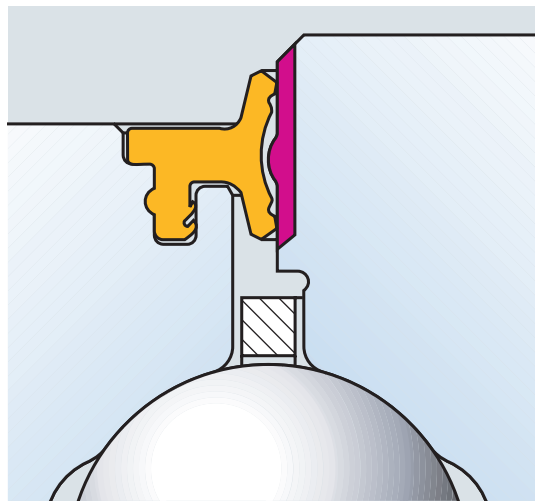



Figure 28

Installation · Lubrication · Maintenance (ILM)

Does not apply to bearings with specific ILM instructions – for replacement deliveries it is essential to get into contact with the machine manufacturer regarding installation, lubrication and maintenance.

thyssenkrupp rothe erde Germany GmbH offers an extensive slewing bearing service (see chapter Service or www.thyssenkrupp-rotheerde.com -> Products and Service).

Transport and handling

 DANGER	
	<p>Danger of life by overhead load</p> <ul style="list-style-type: none"> • Do NOT step underneath the load • Use suitable slings • Use suitable lifting devices • Suitable transport tap hole are stated in the bearing drawing

Slewing bearings, like any other part of a machine, require careful handling. They should always be transported and stored in horizontal position. For safe handling of bearings which include transport holes, high tensile lifting eye bolts must be used. In special cases an internal cross bracing (transporting cross) is required. The bearing weight must be indicated on the crate or pallet. Impact loads, particularly in a radial direction, must be avoided.

Delivery condition

- Raceway system
The slewing bearings are delivered filled with one of the greases (see table 10 on page 229) unless no special lubricant and special grease quantities are required.
- External contours
The external contours of the bearings (except for holes) have Cortec VCI corrosion protection applied.
- Gearing
The gearing is not greased. The corrosion protection is applied as for the external contours.

Storage

ATTENTION	
	<p>Sensitive surface</p> <ul style="list-style-type: none"> • Do not open the packing with a sharp blade • Surface may be damaged





Approx. 6 months in roofed storage areas.
Approx. 12 months in enclosed, temperature-controlled areas (temperature > 12°C).
Outside storage is not allowed.

If required, other corrosion protection agents and types of packaging can be used, e.g. long-term packaging for up to 5 years.

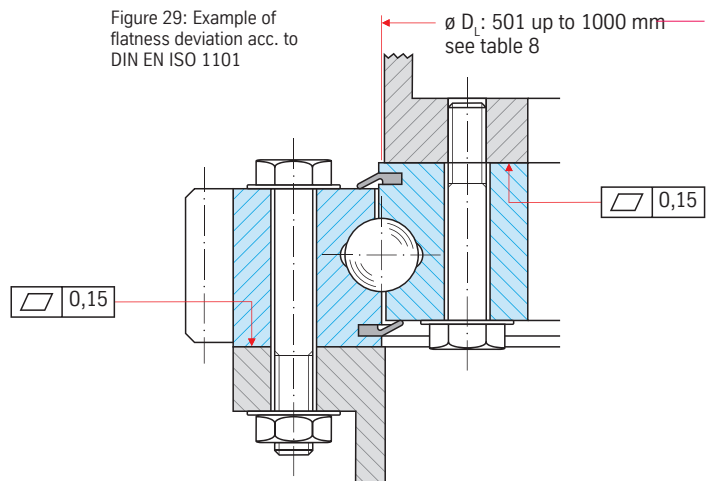
Longer storage periods will necessitate special preservation. After the slewing bearing has been stored for a relatively long time, an increased frictional torque may be observed caused by the suction adhesion of the sealing lip. Careful lifting of the sealing lip with a blunt object around the entire circumference and several clockwise and counterclockwise rotations of the slewing bearing through 360 degrees will reduce the frictional torque to normal.

Figure 29: Example of flatness deviation acc. to DIN EN ISO 1101



 CAUTION	
	<p>Risk of skin irritation caused by preservative</p> <ul style="list-style-type: none"> • Safety gloves must be worn for removal • Pay attention to the producer's data
 DANGER	
	<p>Entrapment hazard when putting the load down</p> <ul style="list-style-type: none"> • Location control before putting the load down • Mind the staff

A flat mounting surface free of grease and oil is essential for the upper and lower ring to seat firmly. Welding beads, burrs, excessive paint and other irregularities must be removed prior to installation. The bearing rings must be completely supported by the connecting structure.

thyssenkrupp rothe erde Germany GmbH recommends conducting a check on the mounting surfaces with a leveling instrument or laser equipment (this service can be provided by thyssenkrupp rothe erde Germany GmbH). The flatness values should not exceed the values shown in table 8. To avoid larger deviations and the occurrence of peaks in smaller sectors, any deviation in the range of 0°–180° may only rise evenly once and fall again.

Table 8: Permitted evenness deviation acc. to DIN EN ISO 1101 on the support surfaces

Track Ø in mm D _L	Flatness acc. to DIN EN ISO 1101 per support surface in mm for		
	BF 01 Double-row ball bearing slewing rings BF 08 Axial ball bearings	BF 06 Single-row ball bearing slewing rings 4-point contact bearings BF 09 – Double 4- point contact bearings BF 25, 23, 28 profile bearings*	BF 19 BF 13 Roller slewing bearings BF 12 Combination bearings
up to 500	0,15	0,10	0,07
up to 1000	0,20	0,15	0,10
up to 1500	0,25	0,19	0,12
up to 2000	0,30	0,22	0,15
up to 2500	0,35	0,25	0,17
up to 4000	0,40	0,30	0,20
up to 6000	0,50	0,40	0,30
up to 8000	0,60	0,50	0,40

The serial number relates to the first two places in the drawing number.
The permitted values in table 1 are not allowed to be used for special configurations as high-precision bearings with high running accuracy and low bearing play, please contact thyssenkrupp rothe erde Germany GmbH:
www.thyssenkrupp-rotheerde.com

*) Double these values are permitted for normal bearings BF 25, BF 23.

Installation · Lubrication · Maintenance (ILM)

Does not apply to bearings with specific ILM instructions – for replacement deliveries it is essential to get into contact with the machine manufacturer regarding installation, lubrication and maintenance.

Mechanical machining of the bearing connection surfaces on the connecting structure is required if the values are exceeded. The mounting position of slewing bearings must correspond to that shown in the drawing. If a transporting cross was delivered, it has to be removed before installation.

The corrosion protection can be removed with an alkaline cleaner. Cleaner must be prevented from coming into contact with the seals or the raceway. Remove the protective coating from the upper and the lower mounting surfaces of the slewing bearing as well as from the gear.

Note The corrosion protection can easily be removed, for example, using a biodegradable alkaline cleaner.

Advantage Rapid removal of the corrosion protection and low environmental impact.

Hardness gap

The unhardened zone between the beginning and the end of the hardened region of the raceway is marked with an “S” on the inner or outer diameter of each bearing ring. On the gear ring, the hardness gap is marked on the axial surface. Wherever possible, the hardness gap “S” must be positioned outside the main load-carrying areas. If the main working area for the application is known, then the hardness gap of the ring loaded on the circumference must also be positioned outside the main load-carrying area.

Commissionings

The bearing must be completely screwed on for commissionings and test runs. Sufficient load / moment load must be applied to avoid a slip-stick effect on the anti-friction bearing bodies.

Gearing

 DANGER	
	<p>Entanglement hazard due to exposed gear</p> <ul style="list-style-type: none"> • Keep hands away from moving parts

The backlash is adjusted relative to the three gear teeth marked in green and should be $0.03\text{--}0.04 \times \text{module}$. After the final tightening of the bearing, the backlash should be rechecked over the entire circumference. A tip edge radius and a tip relief must be provided on the pinion (see the “Gearing” chapter in the catalog *rothe erde*® Slewing Bearings or www.thyssenkrupp-rotheerde.com).

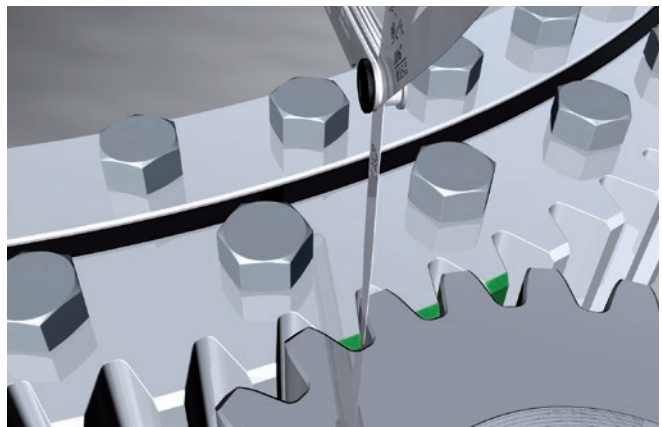

Figure 30: Backlash measurement

Table 9

Thread/ bolt diameters		Hole diameters mm		Tightening torques Nm for bolts in strength class $\mu_G \approx \mu_K = 0,14$	
		DIN EN 20273		for hydr. + electr. M_d -torque wrench 10.9	for M_d -key 10.9
M 12		14		137	123
M 14		16		218	196
M 16		17,5		338	304
M 18		20		469	422
M 20		22		661	594
M 24		26		1136	1022
M 27		30		1674	1506
M 30		33		2274	2046
				Grade 8	Grade 8
UNC	t" – 11	18		286	260
UNC	c" – 10	21		506	460
UNC	u" – 9	25		803	730
UNC	1" – 8	27,5		1210	1100
UNC	1r" – 7	32		1716	1560
UNC	1b" – 7	35		2410	2190
				Grade 8	Grade 8
UNF	t" – 18	18		320	290
UNF	c" – 16	21		560	510
UNF	u" – 14	25		902	820
UNF	1" – 12	27,5		1330	1210
UNF	1r" – 12	32		1936	1760
UNF	1b" – 12	35		2685	2440

Bolting/bolting assembly

Bolt holes on the bearing and connecting structure must match up, otherwise impermissible levels of stress will be established. Through-holes shall be configured acc. to DIN EN 20273, medium series, – see table 9.

Installation · Lubrication · Maintenance (ILM)

Does not apply to bearings with specific ILM instructions – for replacement deliveries it is essential to get into contact with the machine manufacturer regarding installation, lubrication and maintenance.

Fastening bolts

Normal fastening bolts, nuts and washers (without surface treatment) in strength class 10.9 acc. to DIN ISO 267. It is essential to comply with the specified number and diameter. The bolts must be carefully preloaded crosswise to the specified values (table 9 on page 227 gives several recommended values). The surface pressure underneath the bolt head or nut must not exceed the permitted limit values (see the “Fastening bolts” chapter in the catalog rothe erde® Slewing Bearings or www.thyssenkrupp-rotheerde.com, also with regard to the minimum grip of the bolt). If the limiting surface pressure is exceeded, washers of the appropriate size and strength must be provided. The minimum length of engagement must be guaranteed in the case of blind hole threads. If a hydraulic tensioning device is used, it is essential to adhere to the required pro-

jections for the screw threads or stud bolt threads and to use the appropriate washers (see the “Bolts” chapter in the catalog rothe erde® Slewing Bearings or www.thyssenkrupp-rotheerde.com).

The determination of the tightening torque depends not only on the strength class of the bolt and the tightening process but also on the friction in the thread and the contact surface of the bolt head and nut. The tightening torques given in table 9 on page 227 are recommended values based on lightly oiled threads and contact surfaces.

Dry threads will require higher torques whilst heavily oiled threads will require lower tightening torques. The values may, therefore, vary considerably. This applies in particular to threads larger than M 30 or 1b”. For bolts of this size the use of bolt tensioning is recommended.

If the frictional bond is not adequate, it is advisable to use a suitable compound to increase the frictional bond, or else make a form-locking connection. Welding of slewing bearings is not permitted.

Note After prestressing the 8th bolt diagonally across, make one complete circuit. The prestressing of the bolt tightened first is influenced by tightening the other bolts. Therefore, it is necessary to provide at least two rotations.

Lubrication and Maintenance

All the grease nipples must be easily accessible, lubrication lines must be provided if necessary. thyssenkrupp rothe erde Germany GmbH recommends the installation of an automatic central lubricating system. The bearing system and the gearing must be greased immediately after installation. The lubricants specified in table 10 on page 229 are to be used for this and each subsequent lubrication. The only lubrication to be used on the raceway is KP2K grease, i.e. lithium saponified mineral oils of NLGI Grade 2 with EP additives. The raceway lubricants listed in table 10 on page 229 can be mixed together. The lubricants are listed in alphabetical order. The grease fill prevents friction, provides protection against corrosion and is a component of the seal.

Therefore the bearing must always be greased liberally so that a collar of fresh grease forms around the whole circumference of the bearing gap and lip seals. This collar of grease must be removed regularly in order to prevent water building up. The bearing should be rotated during relubrication.

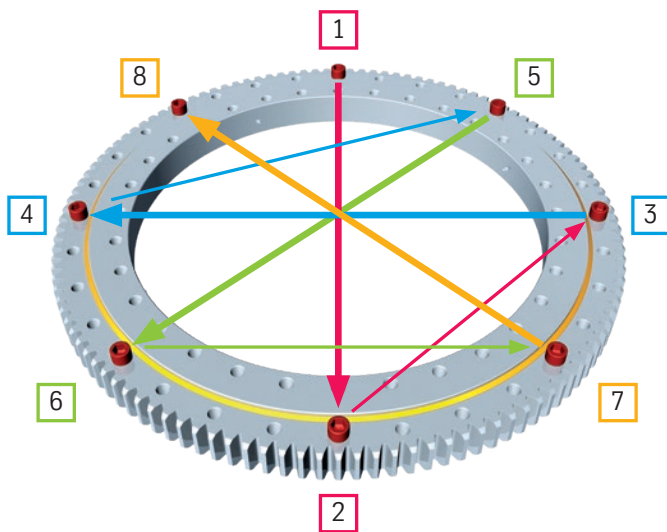



Figure 31: Tightening sequence of the fastening bolts



Table 10: Lubricants

	● Aralub HLP 2	243 K bis 393 K (-30°C bis +120°C)
	▲ Castrol Molub-Alloy OG 936 SF Heavy	243 K bis 373 K (-30°C bis +100°C)
	● Spheerol EPL 2	253 K bis 413 K (-20°C bis +140°C)
	▲ Castrol Molub-Alloy OG 9790/2500-0	253 K bis 363 K (-20°C bis +90°C)
	● Centoplex EP 2	253 K bis 403 K (-20°C bis +130°C)
	▲ Grafloscon C-SG 0 ultra	243 K bis 473 K (-30°C bis +200°C)
	● Lagermeister EP 2	253 K bis 403 K (-20°C bis +130°C)
	▲ Ceplattyn KG 10 HMF	263 K bis 413 K (-10°C bis +140°C)
	● Mobilux EP 2	253 K bis 393 K (-20°C bis +120°C)
	▲ Mobilgear OGL 461	253 K bis 393 K (-20°C bis +120°C)
	● Gadus S2 V220 2	248 K bis 403 K (-25°C bis +130°C)
	▲ Gadus S2 OGH NLGI 0/00	263 K bis 473 K (-10°C bis +200°C)
	● Multis EP 2	248 K bis 393 K (-25°C bis +120°C)
	▲ Copal OGL 0	248 K bis 423 K (-25°C bis +150°C)

- Raceway grease
- ▲ Gear grease

(Symbols see Figure 32, page 230)

Lubricants

 CAUTION	
	<p>Risk of skin irritation caused by lubricants</p> <ul style="list-style-type: none"> Safety gloves must be worn when handling lubricants Pay attention to the producer's data

Queries about lubricants should be directed to the respective manufacturer.

The greases listed in table 10 are approved for our slewing bearings and tested for compatibility with the materials which we use for our spacers and seals. The list of greases is not exhaustive.

Obtain confirmation of suitability from the lubricant manufacturer before using other lubricants. The properties must at least correspond to those of the greases listed in table 10, and compatibility with the materials we use must be assured. When automatic lubricating devices are used, the lubricant manufacturer must confirm that the lubricant selected is suitable for a "pumped" system. Special lubricants are necessary if the bearings are used in extreme temperatures.

Lubricants are contaminants. They must not be allowed to get into the ground, the groundwater, or into the water and sewage system.

Installation · Lubrication · Maintenance (ILM)

Does not apply to bearings with specific ILM instructions – for replacement deliveries it is essential to get into contact with the machine manufacturer regarding installation, lubrication and maintenance.

Relubrication of the raceway system

The bearing should be rotated during relubrication until a fresh collar of grease is seen to form around the whole circumference of the bearing gaps and lip seals. It is the responsibility of the maintenance personnel to ensure that the correct amounts of grease at individual regular intervals are administered to the bearing, determined by regular monitoring of the lubricated condition of both the bearing raceway and gear. The amount of lubrication will need to be increased and the lubrication intervals shortened in extreme conditions, e.g. in the tropics, where humidity levels (moisture) are raised, exposure to dust and dirt is high, and extreme temperature fluctuations prevail.

Bogie bearings for railway and tram vehicles as well as bearings for wind energy turbines are subject to special requirements, and thyssenkrupp rothe erde Germany GmbH should be contacted in such cases.

In the case of partially assembled bearings, or if there is a long period between bearing installation and equipment commissioning, then appropriate maintenance procedures will be required, e.g. relubrication under rotation or adequate slewing after no more than three months and thereafter every three months. Relubrication is absolutely essential before and after prolonged shut-down of the equipment. The bare metal bearing contours and holes must have corrosion protection applied, and must be checked regularly.

Cleaning the equipment

When cleaning the equipment, care must be taken to prevent cleaning agents or water from damaging the seals or penetrating into the raceways.

Lubrication intervals for the gear

We recommend automatic gear lubrication. This is because the tooth flanks should always have sufficient grease applied

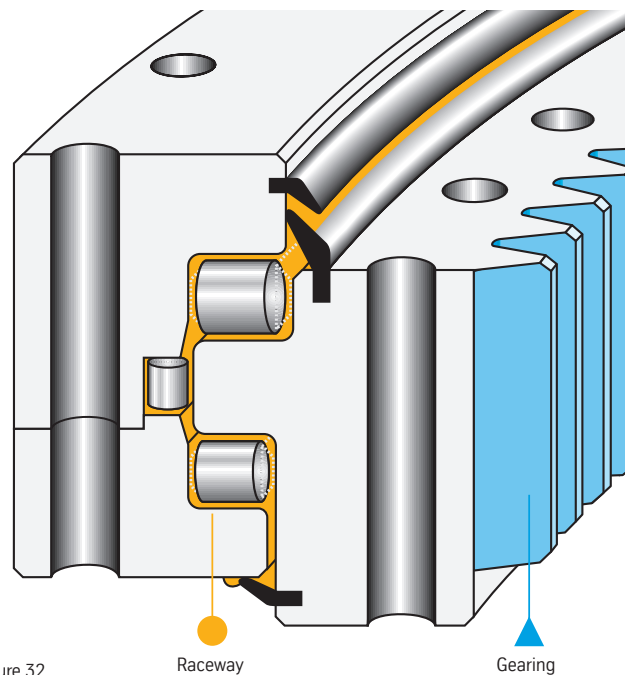

Figure 32

relative to both the application and the duty. It is the responsibility of the maintenance personnel to ensure that the correct amounts of grease at individual regular intervals are administered to the gearing, determined by regular monitoring of the lubricated condition.



Note Effective lubrication is essential for the raceway system and the gearing. This is the only way to achieve a satisfactory service life.

Advantage Optimum use of lubricant and intervals increase the availability of the system.

Examination of bolts

The bolted connection must be capable of maintaining a pre-designated preload during the entire life of the bearing. Experience has shown that it is advisable to check the bolt torques on a regular basis and to retighten the bolts to compensate for any settlement phenomena.

Checking of the raceway system

 DANGER		
	<p>Exceeding the maximum permissible wear rates involves the risk of accidents and danger of life</p> <ul style="list-style-type: none"> • When reaching the wear limits the machine must be put out of operation 	
SAFETY INSTRUCTIONS		
<ul style="list-style-type: none"> • While in operation it must be assured that the wear limits of the bearing will not be reached. With regard to further information (sketches/procedures) see www.thyssenkrupp-rotheerde.com. • The resulting wear must be regularly determined and recorded • The procedure is included in the manual • In case of open questions thyssenkrupp rothe erde Germany GmbH must be contacted 		

When the bearing is put into operation, we recommend that tilting play or subsidence should be measured (see the “Bearing inspection” chapter in the catalog rothe erde® Slewing Bearings or www.thyssenkrupp-rotheerde.com). Make sure that the wear limits of the bearing are not reached. We recommend repeating this measurement at suitable intervals. In addition, a sample of the used grease can be taken for analysis.

Checking of the seal

Check seals at least every 6 months, renew the seal if it is damaged.

Inspecting the gearing

Gear teeth become smoothed and worn in the course of use. A permissible wear limit depends very much on the application. Experience indicates that a wear value of up to 0.1 x module per flank is permissible.

thyssenkrupp rothe erde Germany GmbH Service assistance

For a continuous and undisturbed operation of our bearings we offer our following service:

Installation

Assessment of the contact surfaces/
laser measurement

Bearing installation

Reference measurement

Commissioning

Maintenance and inspection

Wear measurement

Check of bolts

Lubricant analysis

Seal exchange

Reconditioning

Repair

General overhaul

Others

Trainings

Technical support

Bearing inspection

Preventing damage

Wear measurements enable early detection of technical problems before they result in unscheduled plant stoppages. Unnecessary repair costs and expensive production downtimes are thus avoided. We therefore recommend regular bearing wear measurements in order to assess the condition of a bearing.

The wear which affects the raceway system makes itself felt in a change of the axial motion or the axial reduction. Depending on the application or bearing version, this increase in wear can be determined by measuring the tilting clearance or by taking reduction measurements.

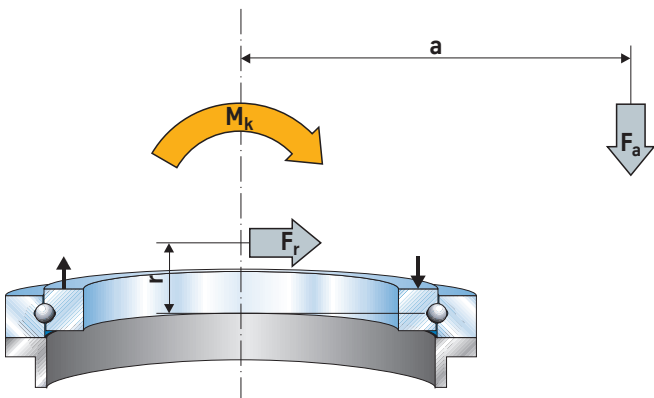

Figure 33: Loading principle of the tilting clearance measurement (axial motion)

Measuring the tilting clearance

To determine the wear, we recommend carrying out tilting clearance measurements wherever possible. The loading principle for such measurements is shown in figure 33.

The measurements are taken between the lower companion structure and the bearing ring which is bolted to the superstructure (figure 5). The measurements must be taken as close to the raceway system as possible in order to minimize the impact of elastic deformations in the companion structure.

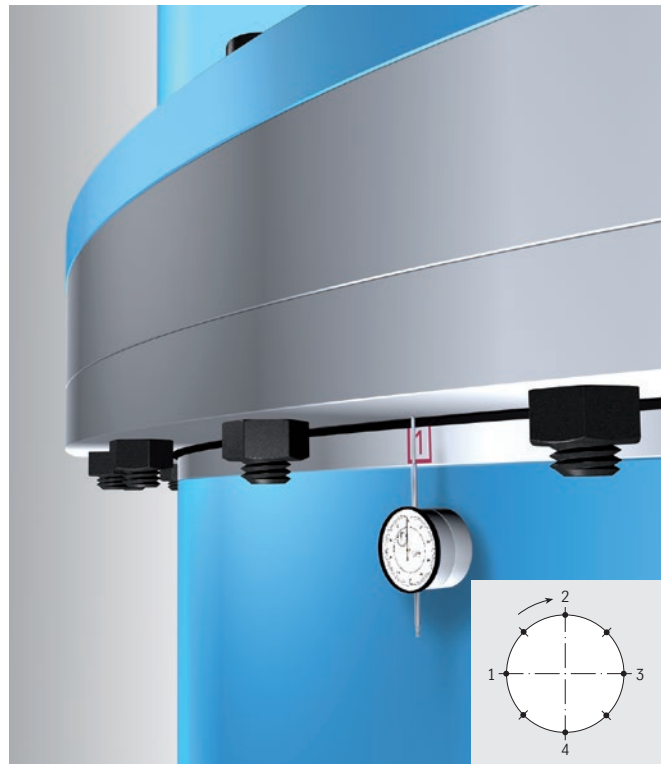

Figure 34: Basic setup for measuring the tilting clearance

The procedure is as follows:

- Take a reference measurement when the equipment is put into operation.
- Mark the measuring points around the circumference starting from a defined position.
- First apply the maximum retrograde moment in order to set the dial gauges to zero (the gauges must have a measuring accuracy of 0.01 mm). Then apply a forward tilting moment, with load uptake if necessary.
- Swivel the superstructure and repeat the measurements at the marked measuring points (see table 14 on page 239).

Maximum permissible increase in bearing clearance (uniform wear)

These increases in bearing clearance are not permissible for special applications, e.g. 50% of the listed values for fairground ride slewing bearings (contact thyssenkrupp rothe erde Germany GmbH).

Table 11: Series* 01, 08 (double-row ball bearings/axial ball bearings)

Measuring method	Ball diameter mm										
	18	20	22	25	30	35	40	45	50	60	70
	max. permissible wear values up to mm										
Axial reduction measurement	1.8			2.2			3.0			3.8	
Tilting clearance measurement	2.5			3.0			4.0			5.0	

*see 1. and 2. figure of the drawing number (fold-out back page "Structure of the drawing number")

Table 12: Series* 06, 09, 25, 23, 28 (four-point bearings/profile bearings)

Measuring method	Ball diameter mm									
	20	22	25	30	35	40	45	50	60	70
	max. permissible wear values up to mm									
Axial reduction measurement	1.6		2.0			2.6			3.3	
Tilting clearance measurement	2.0		2.6			3.2			4.0	

*see 1. and 2. figure of the drawing number (fold-out back page "Structure of the drawing number")

Table 13: Series* 12, 13, 16, 19 (roller bearing slewing rings)

Measuring method	Roller diameter mm													
	16	20	25	28	32	36	40	45	50	60	70	80	90	100
	max. permissible wear values up to mm													
Axial reduction measurement	0.8			1.2			1.6			2.0			2.4	
Tilting clearance measurement	1.4			2.0			2.8			3.5			4.2	

*see 1. and 2. figure of the drawing number (fold-out back page "Structure of the drawing number")

Bearing inspection

Measuring the axial reduction

Where tilting clearance measurements are not possible we recommend the axial reduction measurement method. In this case the center of the load combinations lies within the race diameter of the bearing. The loading principle is shown in figure 35.

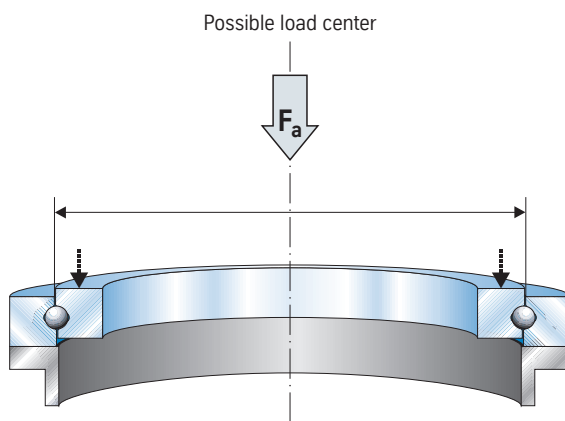

Figure 35: Loading principle of the axial reduction measurement

The measurements are taken between the lower companion structure and the bearing ring which is bolted to the superstructure (figures 36, 37). The procedure is similar to that for measuring the tilting clearance:

- Here too, record reference values when the equipment is put into operation.
- Mark the measuring points around the circumference starting from a defined position.

Repeat the tilting clearance or axial reduction measurements under the same conditions at appropriate intervals, after first checking the bearing fastening bolts. The difference between the current measurement and the reference measurement is the wear which has occurred in the intervening period. If the wear values show a rising trend, you should carry out the measurements more often.



Figure 36: Basic setup for measuring the axial reduction with a depth gauge

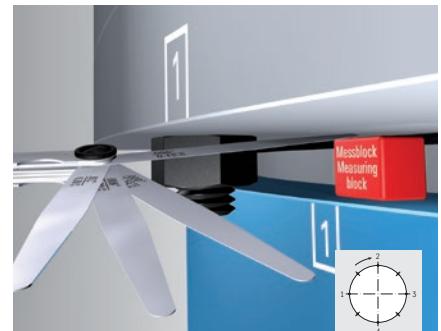

Figure 37: Basic setup for measuring the axial reduction with a feeler gauge

Advantage Given conclusive assessment of the bearing's condition, worn parts can be replaced in good time. In conjunction with optimum spare parts management, it is thus possible to avoid incidents of damage and lengthy downtimes.

Note If the permissible wear values (tables 11, 12 and 13 on page 233) are exceeded, we recommend that the equipment should be shut down.

**The alternative:
IWM (integrated wear measuring device)**

thyssenkrupp rothe erde Germany GmbH always focuses on developing innovative solutions for permanently monitoring the condition of a bearing in order to further optimize the function and reliability of plant operations. The integrated wear measuring device for slewing bearings is a patented invention which enables online inspection of the maximum permissible axial clearance or axial reduction of a slewing connection.

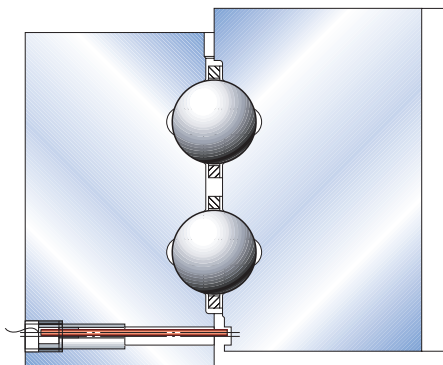

Figure 38

Advantage It is no longer necessary to interrupt operations in order to determine the axial clearance.

A pin made of stainless steel is located in the peak load area of the raceways. The electrically isolated pin is mounted in one ring and protrudes into a groove in the other ring. The maximum tolerated clearance can be adjusted by means of the groove width.

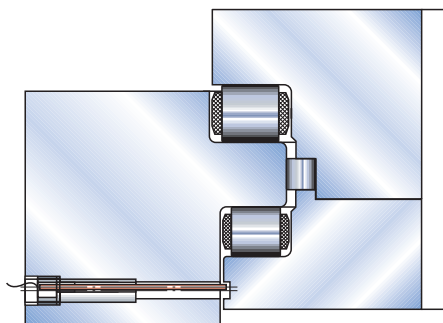

Figure 39

If the clearance changes by an impermissible amount, the ring and the pin will make contact with each other. The pin's electrical connection results in a signal being triggered when the pin touches the other ring. This signal indicates that the permissible relative movement of the rings has been reached and that it is time to inspect the bearing.

Advantage The deformation of the companion structure and the elasticity of the bolt connections do not significantly influence the measurement result. The elastic approximation of the raceways, the axial clearance of the bearing and the out-of-flatness of the contact surface are compensated. Costs for maintenance personnel are minimized.

Bearing inspection





Figure 40: Grease sampling set

Grease sampling set

Grease samples are taken in parallel with, i.e. at the same time as, the inspection measurements. The analysis of the used grease provides additional information about the raceway condition.

Bearings with grease sampling ports

 CAUTION	
	<p>Risk of skin irritation caused by lubricants</p> <ul style="list-style-type: none"> • Safety gloves must be worn when handling lubricants • Pay attention to the producer's data

The grease sampling set comprises a plastic tube, various cap plugs, a suction device, a sample box for up to 5 grease samples, and an information sheet. The procedure is described in detail.

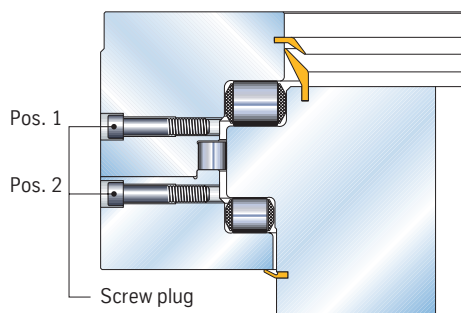

Figure 41: Three-row roller bearing slewing ring with grease sampling ports

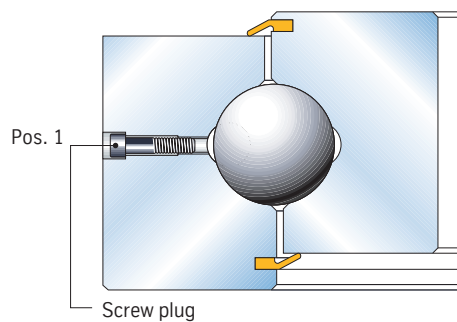

Figure 42: Single-row ball bearing with grease sampling port

Take the grease samples from the main loading zone.

The sampling ports must be closed again with the screw plugs.

Remove the screw plug (M16 EN ISO 4762) selected for taking the sample: item 1 and if necessary item 2 opposite (figures 41 and 42).

When the sample has been taken, close both tube ends with the plastic caps.

Number the grease sample and place it in the labeled sample box.

Before taking the grease sample, cut the supplied tube at an angle of 45° so that it is slightly longer than the grease sampling port. Then insert the tube into the raceway area of the port (figure 43).

Add the necessary information (see the grease sampling set in figure 41 on page 236) to the top of the sample box.

Make sure that the surface cut at 45° faces in the opposite direction to the direction of rotation (figure 44).

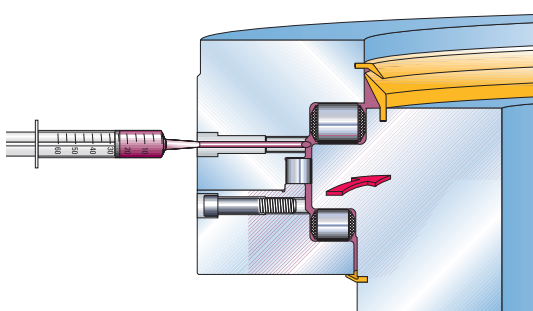

Figure 43: Taking a sample

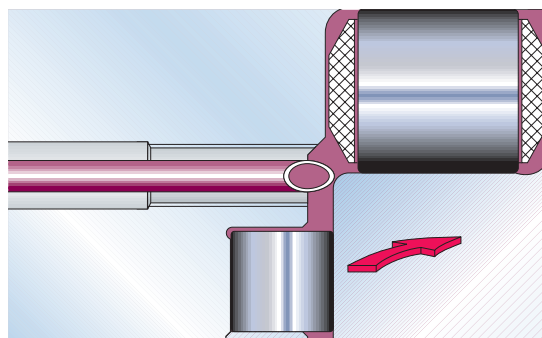

Figure 44: Detail of the sampling

Bearing inspection

Bearings without grease sampling ports

If there are no grease sampling ports provided on the bearing, one or more grease samples are taken at the seal. This area near a grease nipple must be cleaned. The sample should be taken preferably in the main working area and/or offset 180° to it.

During regreasing at the prepared grease nipple (without rotation of the bearing), the first grease escaping from the sealing lip is taken as the sample (figure 45). 3 ccm are enough.

Note Be careful when taking the sample or the result may be falsified by contamination.



Figure 45: Taking a sample of grease from the sealing lip

Fe limit values

A limit value for Fe contamination in the lubricant depends greatly on the operating parameters and the lubrication intervals. Depending on the application, the value can be as high as 20 000 ppm.

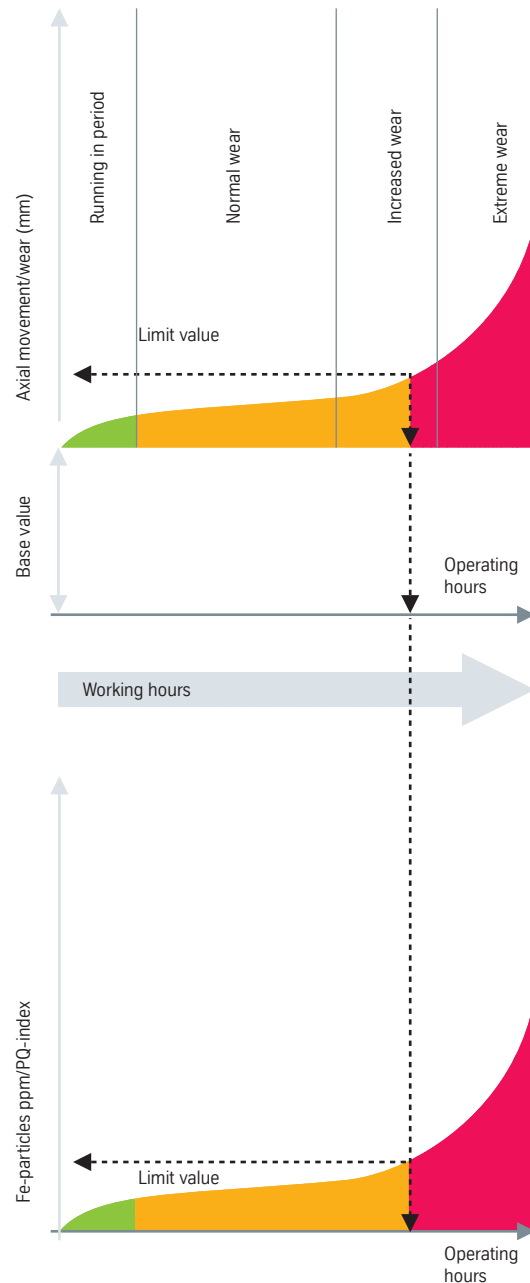

Figure 46: Wear curves

Wear curves

The diagrams show the increase in wear and the increases in Fe particles and the PQ index as a function of the operating hours (figure 46).

For standard applications see the values in tables 11–13 on page 233. When the limit values are reached, please contact thysseknrupp rothe erde Germany GmbH.

Table 14: Measurement table

Customer		Application					Location	
thyssenkrupp rothe erde Germany GmbH drawing no.		thyssenkrupp rothe erde Germany GmbH order no.					Year of manufacture	
Date								
Operating hours								
Measuring point	Basic measurement	Repeated measurement (12 months interval)						
		1	2	3	4	5	6	7
1	Main load area 180° opposite							
2	Main load area 180° opposite							
3	Main load area 180° opposite							
4	Main load area 180° opposite							
Grease sample no. Fe particles ppm/ PQ index	1							
	2							
	3							
	4							
	5							
Grease								
Lubrication system Quantity/interval								
Comments								

The measurement values, analysis values and bearing-specific information should be entered in a separate table (see table 14) and forwarded to thyssenkrupp rothe erde Germany GmbH.

thyssenkrupp rothe erde Germany GmbH
Service
Beckumer Strasse 87
59555 Lippstadt , Germany
service.rotheerde@thyssenkrupp.com

thyssenkrupp rothe erde Germany GmbH sends the grease samples to an approved, qualified laboratory.

Advantage Short processing time and notification by e-mail about the analysis results and wear measurement.

For the **grease sampling** set please contact the following address:

thyssenkrupp rothe erde Germany GmbH
Tremoniastrasse 5–11
44137 Dortmund, Germany
Telephone +49 (2 31) 1 86 - 0
Telefax +49 (2 31) 1 86 - 25 00
sales.rotheerde@thyssenkrupp.com
Disposal at end of useful life

ATTENTION	
	<p>Disposal may involve environmental risks</p> <ul style="list-style-type: none"> • Follow the directives for waste disposal • Mind the national laws

Bearing to be dismantled. Grease, seals and plastic parts to be disposed of in accordance with waste guidelines. Bearing rings and rolling elements to be taken to the relevant material recycling points.

After sales service

The availability of your systems as well as long service life of the bearings are important components in your success!

Due to its many years of experience in plant manufacture, monitoring and maintenance of slewing bearings, thyssenkrupp rothe erde Germany GmbH possesses the highest levels of expertise and has developed a comprehensive support concept that is integrated into its service. Our service is centrally controlled, divided into three areas, and includes the following tasks:

In-house service

External service



Figure 47: Prestressing bolts



Figure 48: Seal renewal

Advantage Optimization of system productivity. Reliable guarantee of continuous and trouble-free, economical operation.

Installation

- Bearing assembly
- Measurement and assessment of the contact surface
- Commissioning

Maintenance and inspection

- Lubricant analysis
- Wear measurement
- Bolt check
- Examination regarding continued use
- Examination of replacement bearings
- Long-term packaging up to 5 years
- Renewal of packaging
- Seal exchange

Repair

(up to 8 m in one piece, up to 20 m divided)

- Repair
- General overhaul

Training measures

- Installation, lubrication, maintenance
- Bearing check
- Preliminary discussion regarding assembly

Proactive service

Customer care

- Working out service concepts
- Creating inspection schedules
- Status analyses of the bearings in your systems
- Detailed reporting

Sample areas

- Ports
- Steel mills
- Wind farms
- Mines
- Amusement park

We are available at all times to ensure your satisfaction, and are ready to help you anywhere in the world:

thyssenkrupp rothe erde Germany GmbH

Service

Beckumer Strasse 87

D-59555 Lippstadt, Germany

Tel. +49 (294) 7 41- 32 93

service.rotheerde@thyssenkrupp.com

www.thyssenkrupp-rotheerde.com



Figure 49: Assembly

All data and contents of this catalog have been produced and examined conscientiously. However, no liability is accepted for possible errors or omissions.

We reserve the right to make technical changes and supplements as a result of further developments. All previous editions are hereby invalidated.

Individual details in this information shall only be considered as guarantees of quality or durability if we have issued written confirmation of the same in any individual case.

This publication may not be reproduced in whole or in part without permission. All rights reserved. Printed in Germany.

ISBN: 978-3-946775-25-6

thyssenkrupp rothe erde
Germany GmbH

Tremoniastraße 5–11
44137 Dortmund
Deutschland
Tel.: +49 (0) 0231 186-0
Fax: +49 (0) 0231 186-2500
www.thyssenkrupp-rotheerde.com
rotheerde@thyssenkrupp.com

engineering.tomorrow.together.